

05/2018

Mod: E9/F18A4

Production code: BBEF498



Diamond
catering equipment

FRYER
OPERATING INSTRUCTIONS

EN



EF477
EF4772V
EF777

EF477T
EF4772VT
EF777T

EF408/908(L)
EF4082V

EF498/998(L)
EF4982V
EF498T/998T

07/2016 - Ed 8 - Cod. n° 177378



ELEKTRYCZNY
ELECTRIC
ELEKTRISCH
ELECTRIQUE
ELÉCTRICO
ELÉTRICO
ELETTRICO
ЭЛЕКТРИЧЕСКИЕ ИЗДЕЛИЯ
ELEKTRISK
ELEKTROMOS



0.

IDENTIFICAZIONE DOCUMENTO - DOCUMENT IDENTIFICATION - IDENTIFICATION DU DOCUMENT
 IDENTIFICACIÓN DEL DOCUMENTO - DOKUMENT-KENNDATEN - IDENTIFICAÇÃO DO DOCUMENTO
 IDENTYFIKACJA DOKUMENTU - DOCUMENTIDENTIFICATIE - ИДЕНТИФИКАЦИЯ ДОКУМЕНТА
 IDENTIFISERING DOKUMENT - DOKUMENT IDENTIFIERING - DOKUMENTUM AZONOSÍTÁSA

CODICE DEL DOCUMENTO - DOCUMENT CODE - CODE DU DOCUMENT - CÓDIGO DEL DOCUMENTO - DOKUMENTNUMMER - CÓDIGO DO DOCUMENTO - KOD DOKUMENTU - DOCUMENTCODE - КОД ДОКУМЕНТА - DOKUMENTKODE - DOKUMENTKOD - DOKUMENTUM KÓDJÁ:	N° 177378
EDIZIONE - EDITION - ÉDITION - EDICIÓN - AUSGABE - EDIÇÃO - WYDANIE - EDITIE - UTGAVE - UTGÁVA - KIADÁS:	2016 Rev. 8 - 07/2016
TIPO DI DOCUMENTO - TYPE OF DOCUMENT - TYPE DE DOCUMENT - TIPO DE DOCUMENTO - DOKUMENTTYP - TIPO DE DOCUMENTO - TYP DOKUMENTU - DOCUMENTTYPE - ТИП ДОКУМЕНТА - TYPE DOKUMENT - TYP AV DOKUMENT - DOKUMENTUM TÍPUSA:	M.U.
MODELLO - MODEL - MODÈLE - MODELO - MODELL - модель - MODELL - MODELL:	ELETTRICO - ELECTRIC - ELECTRIC - ELECTRIQUE ELÉCTRICO - ELEKTRISCH - ELÉTRICO ELEKTRYCZNY - ЭЛЕКТРИКА - VILLAMOS
ANNO DI COSTRUZIONE - YEAR OF CONSTRUCTION - ANNÉE DE FABRICATION - AÑO DE FABRICACIÓN - HERSTELLUNGSJAHR - ANO DE FABRICO - ROK PRODUKCJI - BOUWJAAR - ГОД ИЗГОТОВЛЕНИЯ - BYGGEÅR - DE FABRICO - BYGGEÅR - TILLVERKNINGSÅR - GYÁRTÁS ÉVE:	2016
CONFORMITÀ - CONFORMITY - CONFORMITÉ - DECLARACIÓN DE CONFORMIDAD - KONFORMITÄT - CONFORMIDADE - ZGODNOŚĆ - CONFORMITEIT - НОМПАТИВНОЕ СООТВЕТСТВИЕ - SAMSVARSKLÆRING - ÖVERENSSTÄMMELSE - MEGFELELŐSÉG:	CE

Targa di identificazione - Identification plate - Plaque d'identification - Placa de identificación - Typenschild - Placa de identificação - Tabliczka identyfikacyjna - Identificatielabel - Паспортная табличка - ID-skilt - Identifieringsskylt - Azonosító tábla.

- A - Indirizzo Costruttore - Manufacturer's Address - Adresse du Fabricant - Dirección del fabricante - Anschrift des Herstellers - Endereço do fabricante - Adres Producenta - Adres Fabrikant - Адрес изготовителя - Adresse produsent - Tillverkarens adress - Gyártó címe.
 B - Apparecchiatura Elettrica - Electrical Appliance - Appareil Electrique - Sistema eléctrico - Elektrogerät - Aparelhagem elétrica - Urządzenie Elektryczne - Elektrisch Apparaat - Электрооборудование - Elektrisk apparat - Elektrisk utrustning - Elektromos készülék.
 C - Apparecchiatura Gas - Gas Appliance - Appareil à Gaz - Sistema de gas - Gasgerät - Aparelhagem a gás - Urządzenie Gazowe - Gasapparaat - Газовое оборудование - Gassdrevet apparat - Gas utrustning - Gázkészülék.

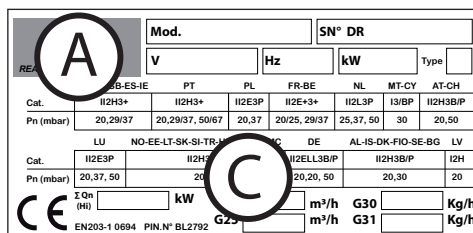
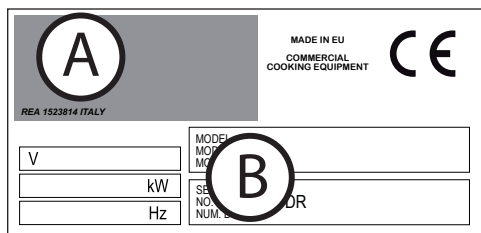

0.1

QUADRO NORMATIVO DI RIFERIMENTO - STANDARDS OF REFERENCE TABLEAU NORMATIF DE REFERENCE - MARCO REGLAMENTARIO DE REFERENCIA - REFERENZNORMEN - QUADRO NORMATIVO DE REFERÊNCIA - RAMY REGULACYJNE ODNIESIENIA - TABEL MET NORMREFERENTIES - СПРАВОЧНЫЕ НОРМАТИВНЫЕ СТАНДАРТЫ - RAMMEBETINGELSER - REGELVERK - VONATKOZÓ SZABÁLYOZÁSI KERET

Direttiva Gas 2009/142/CE (ex-90/396/CEE) Gas Directive 2009/142 EC (ex-90/396/EEC) Directive Gaz 2009/142 CE (ex-90/396/CEE) Directiva sobre los aparatos de gas 2009/142/CE (ex-90/396/CEE) Gas-Richtlinie 2009/142/EG (ex-90/396/EWG) Diretiva Gás 2009/142/CE (ex-90/396/CEE) Dyrektywa o urządzeniach spalających paliwa gazowe 2009/142/WE (ex-90/396/EWG) Gasrichtlijn 2009/142/EG (ex-90/396/EEG) Директива по газовому оборудованию 2009/142/EC (ранее-90/396/EEC) Gassdirektivet 2009/142/CE (tidligere-90/396/CEE) Gas direktiv 2009/142/EG (ex-90/396/CEE) 2009/142/EK Gázüzemű berendezésekről szóló irányelv (korábban 90/396/EEC)	Direttiva Bassa Tensione 2014/35/EU Low Voltage Directive 2014/35/EU Directive Basse Tension 2014/35/EU Directiva de baja tensión 2014/35/EU Niederspannungsrichtlinie 2014/35/EU Diretiva baixa tensão 2014/35/EU Dyrektywa Niskonapięciowa 2014/35/EU Richtlijn lage Spanning 2014/35/EU Директива 2014/35/EU по низковольтному оборудованию Lavspenningsdirektivet 2014/35/EU Lågspänningsdirektivet 2014/35/EU	Direttiva EMC 2014/30/EU EMC Directive 2014/30/EU Directive EMC 2014/30/EU Directiva EMC 2014/30/EU EMV-Richtlinie 2014/30/EU Diretiva EMC 2014/30/EU Dyrektywa EMC 2014/30/EU EMC Richtlijn 2014/30/EU Директива 2014/30/EU по электромагнитной совместимости EMC Direktivet 2014/30/EU EMC direktivet 2014/30/EU	Smaltimento Apparecchiature elettriche ed elettroniche Waste electrical and electronic equipment Démantèlement des Appareils électriques et électroniques Desguace de equipos eléctricos y electrónicos Entsorgung elektrischer und elektronischer Altgeräte Eliminação das aparelhagens elétricas e eletrónicas Utylizacja odpadów elektrycznych i elektronicznych Afgedankte Elektrische en Elektronische Apparaten Утилизация электрического и электронного оборудования Avhending av elektriske og elektroniske apparater Avyttring av elektriska och elektroniska produkter Elektromos és elektronikus készülékek ártalmatlanítása
GAS-GÁS-GAZ GAZOWY-GAZ-GÁZ ELETTRICO ELECTRIC ELECTRIQUE ELÉCTRICO ELEKTRISCH ELÉTRICO ELEKTRYCZNY ЭЛЕКТРИЧЕСКАЯ ELEKTRISK VILLAMOS	EN 62233:2008; EN 60335-2-37:2002 + A1:2008 + A11:2012	EN 55014-1:2006 + A1:2009 + A2:2011 EN55014-2:1997 + A1:2001 + A2:2008 EN61000-3-2:2006 + A1:2009 + A2:2009 EN61000-3-3:2008	DIRETTIVA 2011/65/EU (ROHS II) DIRETTIVA 2012/19/EU (WEEE) IRÁNYELV 2012/19/EU

TABLE OF CONTENTS

- 0. DOCUMENT IDENTIFICATION**
- 0.1 STANDARDS OF REFERENCE**
- 1. INFORMATION FOR USERS**
 - Foreword - Purpose of document - How to read the document
 - Keeping the document - Addressees - Operator training program
 - Pre-arrangements depending on customer - Contents of supply - Intended use
 - Allowed operational and environmental conditions
 - Test inspection and warranty
- 2. GENERAL SAFETY INFORMATION**
 - Foreword - Obligations - Prohibitions - Advice - Recommendations
 - Indications concerning residual risks
 - What to do if you smell gas in the room
- 3. INSTRUCTIONS FOR USE**
 - Location of main components
 - Knobs, keys and indicator light modes and functions
 - Description of stop modes
 - Stoppage due to faulty operations
 - Emergency stop
 - Stoppage during a work phase
 - Commissioning
 - Cleaning at commissioning
 - Daily activation
 - Daily and prolonged deactivation
 - Starting production
 - Loading Oil/Grease in cooking compartment
 - Switching on
 - Loading-Unloading the product
 - Deactivation
 - Burnt oil drain
- 4. ROUTINE MAINTENANCE**
 - Obligations - Prohibitions - Advice - Recommendations
 - Daily cleaning
 - Cleaning for prolonged deactivation
 - Summarised table: qualification - operation - frequency
 - Troubleshooting
 - Waste disposal
- 5. WASTE DISPOSAL**
 - Deactivation and scrapping of appliance
 - Waste disposal

1. INFORMATION FOR USERS

Foreword

This document has been drawn up in the mother language of the manufacturer (Italian). The information it contains is for the sole use of the operator authorised to use the appliance in question.

Operators must be trained concerning all aspects regarding functioning and safety. Special safety prescriptions (Obligations-Prohibitions-Dangers) are carried in a specific chapter concerning these issues. This document cannot be handed over to third parties to take vision of it without written consent by the manufacturer. The text cannot be used in other publications without the written consent of the manufacturer. The use of: Figures/Images/Drawings/Layouts inside the document, is purely indicative and can undergo variations. The manufacturer reserves the right to modify it, without being obliged to communicate his acts.

Purpose of the document

Every type of interaction between the operator and the appliance during its entire life cycle has been carefully assessed both during designing and while drawing up this document. We therefore hope that this documentation can help to maintain the characteristic efficiency of the appliance. By strictly keeping to the indications it contains, the risk of injuries while working and/or of economical damage is limited to a minimum.

How to read the document

The document is divided into chapters which gather by topics all the information required to use the appliance in a risk-free way. Each chapter is divided into paragraphs; each paragraph can have titled clarifications with subtitles and descriptions.

Keeping the document

This document is an integral part of the initial supply. It must therefore be kept and used appropriately during the entire operational life of the appliance.

Addressees

This document is structured for the exclusive use of the "Generic" operator (Operator with limited responsibilities and tasks). Person authorised and employed to operate the appliance with guards active and capable of performing routine maintenance (cleaning the appliance).

Operator training program

Upon specific demand by the user, a training course can be held for operators in charge of using the appliance, following the modalities provided in the order confirmation.

Depending on the demand, preparation courses can be held at the site of manufacturer or of the user, for:

- Homogeneous operator in charge of electric/electronic maintenance (Specialised technician);
- Homogeneous operator in charge of mechanical maintenance (Specialised technician);
- Generic operator for simple operations (Operator - Final user).

Pre-arrangements depending on customer

Unless different contractual agreements were made, the following normally depend on the customer:

- setting up the rooms (including masonry work, foundations or channelling that could be requested);
- smooth, slip-proof, perfectly level floor;
- pre-arrangement of installation place and installation of equipment respecting the dimensions indicated in the layout (foundation plan);
- pre-arrangement of auxiliary services adequate for requirements of the system (electrical mains, waterworks, gas network, drainage system);
- pre-arrangement of electrical system in compliance with regulatory provisions in force in the place of installation;
- sufficient lighting, in compliance with standards in force in the place of installation;
- safety devices upstream and downstream the energy supply line (residual current devices, equipotential earthing systems, safety valves, etc.) foreseen by legislation in force in the country of installation;
- earthing system in compliance with standards in force;
- pre-arrangement of a water softening system, if needed (see technical details).

Contents of the supply

- Appliance
- Lid/s
- Metallic rack/s
- Rack support grid
- Pipes and/or wires for connections to energy sources (only when indicated in work order).

The supply may vary depending on the order.

1. INFORMATION FOR USERS

Intended use

Original instructions. This device is intended for professional use. The use of the appliance treated in this document must be considered "Proper Use" if used for cooking or regeneration of goods intended for alimentary use; any other use is to be considered "Improper use" and therefore dangerous. The appliance must be used according to the foreseen conditions stated in the contract within the prescribed capacity limits carried in the respective paragraphs.

Allowed operating conditions

The appliance has been designed to operate only inside of rooms within the prescribed technical and capacity limits. The following indications must be observed in order to attain ideal operation and safe work conditions.

The appliance must be installed in a suitable place, namely, one which allows normal running, routine and extraordinary maintenance operations. The operating area for maintenance must be set up in such a way that the safety of the operator is not endangered.

The room must also be provided with the features required for installation, such as:

- maximum relative humidity: 80%;
- minimum cooling water temperature $> + 10\text{ }^{\circ}\text{C}$;
- the floor must be anti-slip, and devices positioned perfectly level;
- the room must be equipped with a ventilation system and lighting as prescribed by standards in force in the country of the user;
- the room must be set up for draining greywater, and must have switches and gate valves which cut all types of supply upstream the appliance when needed;
- The walls/surfaces immediately close/contact to the appliance must be fireproof and/or isolated from possible source of heat

Test inspection and warranty

Testing: the equipment has been tested by the manufacturer during the assembly stages at the site of the production plant. All certificates relating to the testing carried out we will be delivered to the customer.

Warranty: The guarantee is of 12 months from invoice date and it covers the faulty parts only. Carriage and installation charges are for the buyer's account. Electric components, accessories as well as other removable parts are not covered by the guarantee.

Labor costs relating to the intervention of authorized by the manufacturer at the customer's premises, for removal of defects under warranty are charged to the dealer, except in cases where the nature of the defect is such that it can be easily removed on site by the customer.

Excluded are all tools and supplies, possibly supplied by the manufacturer together with the machines.

Damage occurred in transit or due to incorrect installation or maintenance can't be considered. Guarantee is not transferable and replacement of parts and appliance is at the final discretion of our company. The manufacturer is responsible for the device in its original setting.

The manufacturer declines all responsibility for improper use, for damages caused as a result of operations not covered in this manual or not authorized in advance by the manufacturer.

The warranty terminates in case of:

- Damage caused by transportation and/or handling. Should this occur, the customer must inform the dealer and carrier via fax or RR and must write what has happened on the copies of the transportation documents. The specialised technician installing the appliance will assess whether it can be installed depending on the damage.

The warranty also terminates in the presence of:





- Damage caused by incorrect installation;
- Damage caused by parts worn due to improper use;
- Damage caused by use of unadvised or non-original spare parts;
- Damage caused by incorrect maintenance and/or lack of maintenance;
- Damage caused by failure to comply with the procedures described in this document.

Authorisation















Authorisation refers to the permission to operate an activity intrinsic to the appliance.

Authorisation is given to anyone who is responsible for the appliance (manufacturer, purchaser, signer, dealer and/or location owner).

Foreword





	The operating instructions have been drawn up for the "Generic" operator (Operator with limited responsibilities and tasks). Person authorised and employed to operate the appliance with guards active and capable of performing routine maintenance (cleaning the appliance).
	The operators who use the appliance must be trained in all aspects concerning its functioning and safety features. They must therefore interact using appropriate methods and instruments, complying with required safety standards.
	This document does not include information regarding transportation, installation and extraordinary maintenance which must be performed by technicians qualified for the relevant operation.
	The "Generic" operator to whom this document is intended must operate on the appliance after the technician has completed installation (transportation, fixing electrical, water, gas and drain connections).
	This document does not include information regarding every modification or variation on the appliance. The manufacturer reserves the right to modify it, without being obliged to communicate his acts.

Obligations - Prohibitions - Advice - Recommendations

	Upon reception, open the packaging and make sure that the appliance and accessories have been damaged during transportation. If damage is found, report it promptly to the carrier and do not install the appliance. Contact qualified and authorised personnel to report the problem detected. The manufacturer is not liable for damage caused during transportation.
	Unauthorised persons (including children, disabled individuals and people with limited physical, sensory and mental abilities) are prohibited from performing any procedures. Generic operators are prohibited from performing any procedures reserved for qualified and authorised technicians.
	Read the instructions before acting.
	Disconnect all supplies (electrical - gas - water) upstream the appliance whenever you need to work in safe conditions.
	Wear protective equipment suitable for the operations to be performed. As far as personal protective equipment is concerned, the European Community has issued Directives which the operators must comply with. Noise ≤ 70 dB
	Do not leave flammable objects or material near the appliance. Do not obstruct the heat extraction and/or dissipation openings.
	Refer to standards in force for disposal of special waste.
	When loading the product into the appliance and unloading it, there is a residual risk of being burnt; this risk can occur coming into unintentional contact with: surfaces, trays, processed material.
	Use the cooking vessels in such a way that while the product is cooking, they are in the operator's sight. Liquid containers can spill during cooking, thus creating dangerous situations.
	Failure to keep the appliance in hygienic conditions could cause it to deteriorate quickly, influencing operation and creating dangerous situations.
	It is strictly forbidden to tamper with or remove the plates and pictograms applied to the equipment.
	Store this document carefully, so that it is available for whoever uses the appliance, consulting it when needed.
	The controls on the appliance can only be switched by hand. Damage caused by sharp objects or the likes terminate all and any warranty rights.
	In order to minimise the risk of shocks or fire, do not connect or disconnect the unit with wet hands.
	Whenever you access the cooking area, always remember that the danger of being burnt persists. It is therefore mandatory to take appropriate measures for personal protection.

Indications concerning residual risks

Though the rules for "good manufacturing practice" and the provisions of law which regulate manufacturing and marketing of the product have been implemented, "residual risks" still remain which, due to the very nature of the appliance, were not possible to eliminate. These risks include:

	Residual risk of electrocution: This risks remains when intervening on live electrical and/or electronic devices.
	Residual risk of burning: This risks remains when unintentionally coming into contact with materials at high temperatures.
	Residual risk of burning due to leaking material This risks remains when coming into contact unintentionally with leaking materials at high temperatures. Containers too full of liquids and/or solids which when heated change morphology (passing from a solid state to a liquid state) can cause burning if used improperly. During work, the containers which are used must be positioned at easily visible levels.
	Residual risk of explosions This risk remains when: <ul style="list-style-type: none"> • there is smell of gas in the room; • appliance used in an atmosphere containing substances which risk exploding; • using food in closed containers (such as jars and cans), if they are not suitable for the purpose; • using with flammable liquids (such as alcohol).

3. INSTRUCTIONS FOR USE

Location of main components

The layout of the figures is purely indicative and can undergo variations.

1. Lid
2. Rack
3. Cooking compartment
4. Switch-on unit (see Knobs, keys and indicator light modes and functions)
5. Gate valve for emptying oil from cooking compartment
6. Burnt oil collection container.

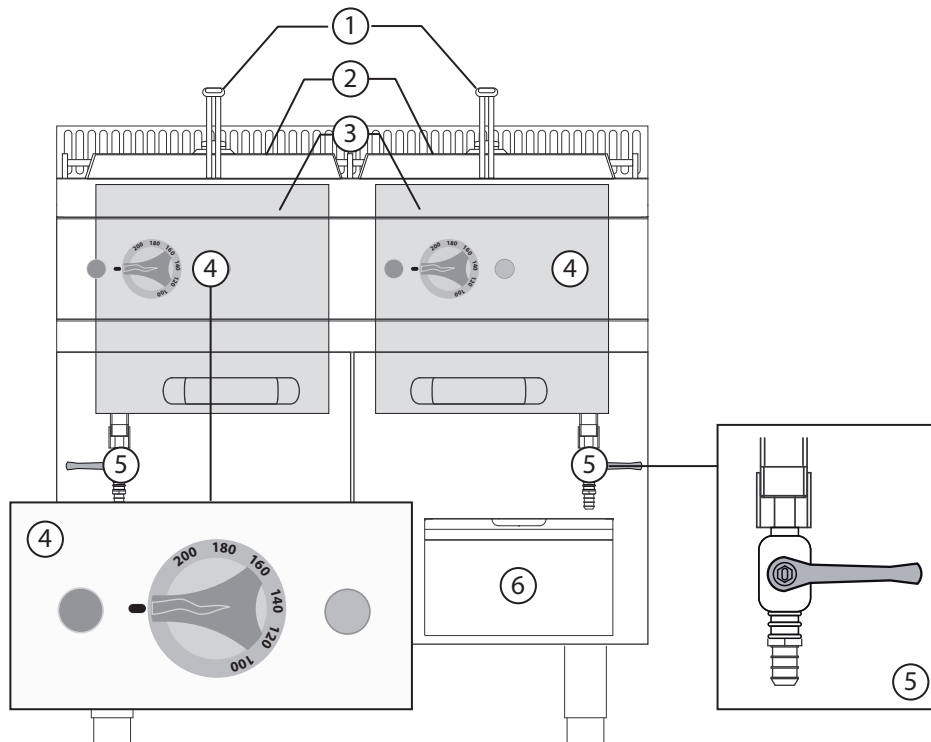



Knobs, keys and indicator light modes and functions

	<p>Switch-on and thermostat knob (ELECTRIC). It performs three different functions:</p> <ol style="list-style-type: none"> 1. Switches electricity inside circuit on and off. 2. Adjusting cooking temperature. 3. Heating phase Start/Stop.
	<p>Yellow indicator light (GAS/ELECTRIC): When present, the indicator is subordinated to use of the thermostat knob. Lighting of the indicator signals the heating phase.</p>
	<p>Green indicator light (GAS/ELECTRIC): The indicator is subordinated to use of the switch-on knob. Lighting of the indicator signals the operating phase.</p>
	<p>Water drainage gate valve (GAS/ELECTRIC). Functions:</p> <ol style="list-style-type: none"> 1. Gate valve for draining water from cooking compartment.

3. INSTRUCTIONS FOR USE

Description of stop modes

	In stoppage conditions caused by faults and emergencies, in the event of imminent danger, it is mandatory to close all the locking devices on the supply lines upstream the appliance (Electrical-Water-Gas).
	The drawing illustrates the various positions the knobs take on during an emergency stop (A1-B1-C1-D1-E1) and stoppage during a working phase (A2-B2-C2-D2-E2).

Stoppage due to faulty operations

Safety thermostat

Standard supply with following models:

- Fryer (present on all models)
- Tilting Pan (present on all models)
- Pot (present on all models)
- Pasta cooker (only with Electric model)
- Stove (present on all models with electric oven)
- Frytop present on all electric models (only for 900)
- Lava stone (not present)
- Bain-marie (not present)
- All hotplate (only for 900: present on all models with gas oven)

Stop: In situations or circumstances which can be dangerous, a safety thermostat is triggered, automatically stopping heat generation. The production cycle is interrupted until the cause of the fault is resolved.

Restarting: After the problem that triggered the safety thermostat is resolved, the authorised technician can restart the appliance by means of the specific controls.

Emergency stop

In situations or circumstances which can be dangerous, turn the knob to “Zero” depending on the model (A-B-C-D-E-1). See knobs, keys and indicator light modes and functions.

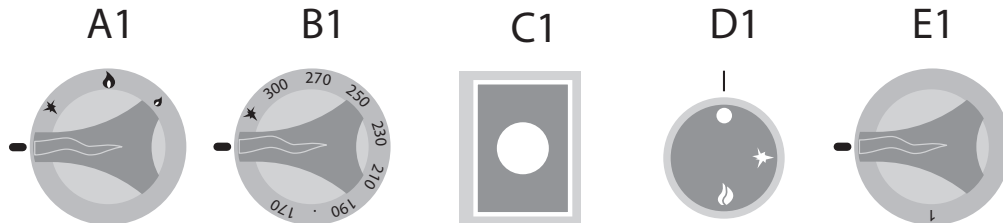

Stoppage during a work phase

In situations or circumstances which require temporary stop of heat generation, act as follows:

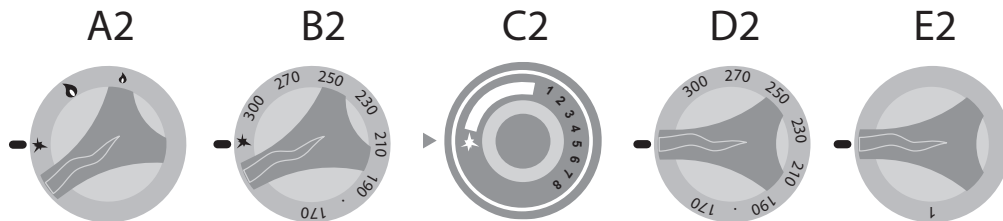

- Gas Appliance: Turn the knobs to the piezoelectric position (A-B-C-2), the pilot light remains lit as the gas flow in the burner is not interrupted.
- Electric Appliance: Turn the knobs “D2-E2” to “Zero” to stop heat generation.

(See knobs, keys and indicator light modes and functions).



3. INSTRUCTIONS FOR USE

Commissioning

	When commissioning the appliance and when starting it after a prolonged stop, it must be thoroughly cleaned to eliminate all residue of extraneous material (See Routine Maintenance).
	Cleaning at commissioning Do not use pressurised or direct water jets to clean the appliance. Remove the outer protective film by hand and thoroughly clean all the outside parts of the appliance. At the end of the operations described for cleaning the outside parts, proceeded as instructed in "Daily Cleaning" (See Routine Maintenance).

Daily activation

Procedure:

1. Check the cleanliness and hygiene of the appliance.
2. Make sure that the room exhaust system works properly.
3. When necessary, plug the appliance into the appropriate socket.
4. Open the network locks upstream the appliance (Gas - Water - Electric).
5. Make sure that the water drain (if present) is not clogged.
6. Proceed with the operations described in "Starting production".

Daily and prolonged deactivation







Procedure:

1. Close the network locks upstream the appliance (Gas - Water - Electric).
2. Make sure that the drain cocks (if present) are "Closed".
3. Check the cleanliness and hygiene of the appliance (See Routine Maintenance).

	In the event of prolonged inactivity, protect the parts more exposed to oxidation as described in the specific chapter (See Routine Maintenance).
---	---

3. INSTRUCTIONS FOR USE



Starting production

	Before proceeding with these operations, see "Daily activation".
	When loading the product into the appliance and unloading it, there is a residual risk of being burnt; this risk can occur coming into unintentional contact with: hob - cooking compartment - recipients or material processed.
	Take appropriate measures for personal protection. Wear protective equipment suitable for the operations to be performed.
	Start the appliance only after having filled the cooking compartment with oil/grease at the proper level. Any other use is considered improper and therefore dangerous.
	Too much oil/grease inside the cooking compartment can cause it to spill over and the residual risk of being burnt remains. While filling, respect the Min and Max level carried in the cooking compartment.
	If there is no oil inside the cooking compartment while the appliance is on, there is the residual risk of fire. While operating, the oil/grease level inside the cooking compartment must remain within the indicated limits.
	Do not cover the cooking compartment or pour salt or seasoning inside of it while it is on.

Loading Oil/Grease in cooking compartment

The appliance can have one or two gate valves. Open the door and make sure the oil/grease drain gate valve is at "Closed" (Fig. 1).

Pour the product used for cooking (oil or grease) into the cooking compartment, respecting the minimum/maximum level shown inside of it (Fig. 2).

	The level of the oil increases approximately 1 cm at the maximum temperature compared to the cold level.
	When using grease (lard or the likes) in the solid state, the thermostat must be set at minimum to allow it to melt slowly and gradually inside the cooking compartment.

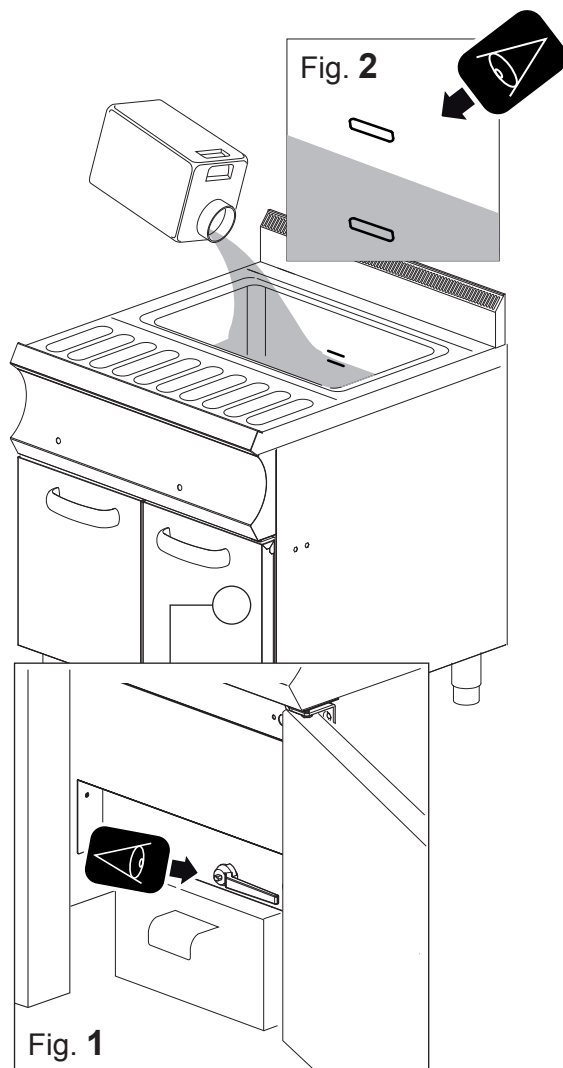

3. INSTRUCTIONS FOR USE

Switching On/Off

	The appliance must be switched on after having filled the cooking compartment with oil/grease. Do not switch it on when the cooking compartment is empty. Do not top up the level while the appliance is running.
	The working temperature is indicated on the thermostat knob. The minimum temperature is approximately 55°C and the maximum temperature it can reach is approximately 200°C.

When the operations described on the previous page have been performed successfully, do as follows to begin cooking:

1. Turn the knob to the desired position (Fig. 3A). The indicator lights “G” and “H” indicate an operating phase.
2. Turn the knob to “Zero” (Fig. 3B) to stop heat generation and to switch the appliance off at the end of the work cycle.

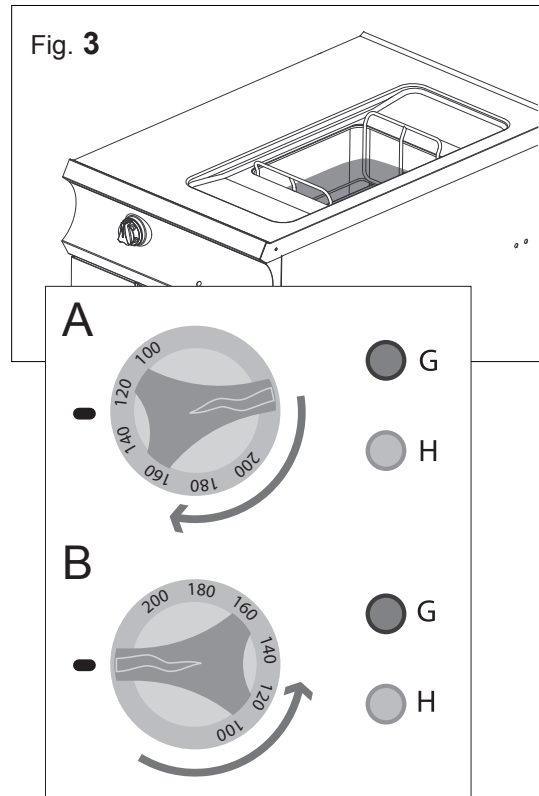

Loading/Unloading the product

	The amount of the product inside the container must not exceed 3/4 the capacity of the recipient (rack Fig.4). For example: french fries/chips (6x6 mm) 1.5 kg for model 700 - 2.5 kg for model 900-980 - 1 kg for model 2V - 3.5 kg for model L
	Wait for the desired temperature to be reached before placing the rack in the cooking compartment.
	The product being cooked must be fully dipped into the oil in the cooking compartment.

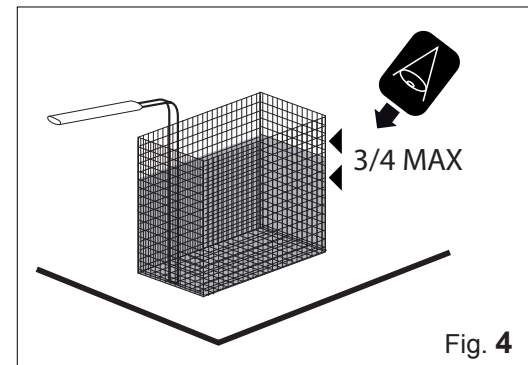

The products to be cooked must be placed in the specific containers and positioned correctly in the cooking compartment.

When the rack has been filled away from the appliance, introduce it slowly into the cooking compartment, positioning it in the specific housing (Fig. 5).

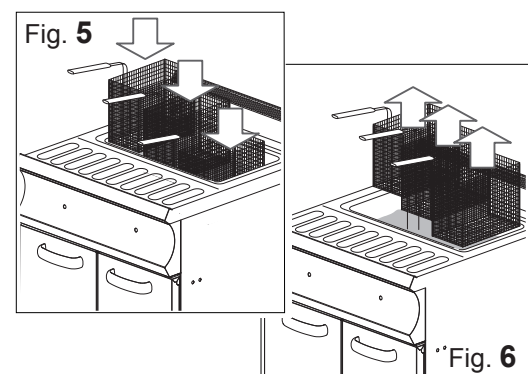

When cooking is over, remove the container from the cooking compartment (Fig.6) and put it in a place prepared beforehand.

After the product has been unloaded, load it once again or else perform the operations described in “Deactivation”.



3. INSTRUCTIONS FOR USE





Deactivation

	The appliance must be cleaned regularly and every incrustation or food deposit removed. See chapter: "Maintenance".
	If present, the indicator lights must be off at the end of the work cycle (Fig.7).

If needed, close the cooking compartment with the specific lids or else proceed with the following operations in order:

- Burnt oil drain.
- Routine maintenance.

Burnt oil drain

	While draining burnt oils, the risk of being burnt remains. This risk can occur by unintentional contact with oil processed at high temperatures.
	Before operating, wait for the oil inside the cooking compartment to cool off.
	Free the cooking compartment from containers used during cooking.
	The burnt oil collection container has a limited capacity. Keep an eye on the container as it fills while oil is emptied from the cooking compartment.
	Do not fill the collection container beyond 3/4 its capacity to handle it safely.

Open the door of the appliance and make sure the collection container is underneath the drainage gate valve (Fig. 8).

After having made sure that the container is in its housing (empty), open the drainage gate valve (Fig. 9) and let exhaust oil empty from the cooking compartment into the container, keeping an eye out not to fill it beyond 3/4 its capacity.

When it is full, close the gate valve (Fig. 10).

Remove the container from its seat and empty it in compliance with waste disposal procedures in force in the country of use (Fig.11).

Then reposition the empty container in its seat (Fig.12).

If necessary, repeat the operations described above until the cooking compartment is completely empty. When the operation is over, close the door of the appliance.





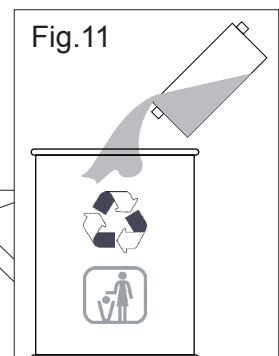
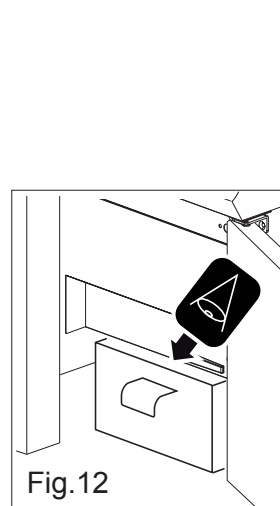
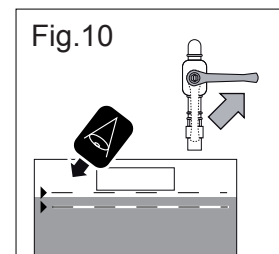
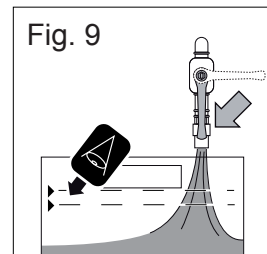
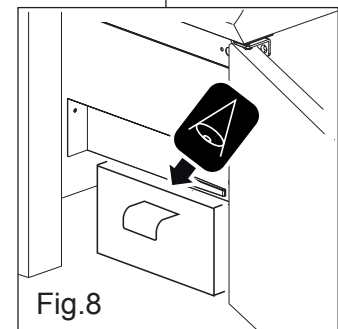
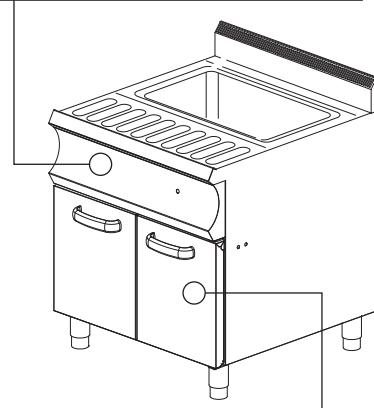
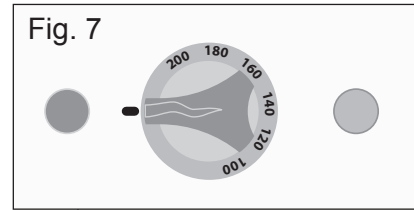















Close the network locks upstream the appliance (Gas - Water - Electric).

Check the cleanliness and hygiene of the appliance and of the cooking containers. See "Maintenance".



4. ROUTINE MAINTENANCE

Obligations - Prohibitions - Advice - Recommendations

	If the appliance is connected to a flue, the exhaust pipe must be cleaned according to that foreseen by specific regulatory provisions of the country (contact your installer for information).
	To make sure that the appliance is in perfect technical conditions; have it serviced at least once a year by an authorised technician of the assistance service.
	Unauthorised persons (including children, disabled individuals and people with limited physical, sensory and mental abilities) are prohibited from performing any procedures. Performing any procedures without first having read all the documentation is strictly prohibited.
 	Whenever you access the cooking area, always remember that the danger of being burnt persists. It is therefore mandatory to take appropriate measures for personal protection.
 	Disconnect electrical power upstream the appliance whenever you need to work in safe conditions to perform cleaning or maintenance.
	Wear protective equipment suitable for the operations to be performed. As far as personal protective equipment is concerned, the European Community has issued Directives which the operators must comply with.
	The appliance is used to prepare food products. Keep the appliance and the surrounding area constantly clean. Failure to keep the appliance in ideal hygienic conditions could cause it to deteriorate quickly and create dangerous situations.
	Filth deposit built up near heat sources can burn during normal use of the appliance and create dangerous situations. The appliance must be cleaned regularly and every incrustation or food deposit removed.
	The chemical effect of salt and/or vinegar or other acid substances can in the long run cause the inside of the hob to corrode during cooking. At the end of the cooking cycle of such substances, the appliance must be washed thoroughly with detergent, abundantly rinsed and carefully dried.
	Be careful not to damage stainless steel surfaces. Do not use corrosive products, abrasive material or sharp tools.
	The liquid detergent for cleaning the hob must have certain chemical features: pH greater than 12, without chlorides/ammonia, viscosity and density similar to water. Use non-aggressive products for cleaning the inside and outside of the appliance (use detergents on the market for cleaning steel, glass and enamel).
	Carefully read the indications carried on the labels of the products used. Wear protective equipment suitable for the operations to be performed (see the protective equipment carried on the package label).
	Do not use pressurised or direct water jets to clean the appliance. Rinse the surfaces with tap water and dry them with an absorbent cloth or other non-abrasive material.
	In the event of prolonged inactivity, besides disconnecting the supply lines, you must thoroughly clean all the inside and outside parts of the appliance.
	Before performing any of the cleaning operations described hereafter, the operator must have had a look at the whole document.
   	Refer to standards in force for waste disposal.

4. ROUTINE MAINTENANCE



Daily cleaning

Wait for the appliance to cool off.
Remove everything from the cooking compartment.
Empty oil from the cooking compartment (see burnt oil drain procedure).

Turn the heating coil 90° by hand to the vertical position (Fig. 13).

Use a standard sprayer to apply the liquid detergent on the whole surface (cooking compartment, heating coil, lid and all exposed surfaces) and using a non-abrasive sponge, clean the entire appliance thoroughly by hand.

When finished, rinse abundantly with tap water (do not use pressurised and/or direct water jets).

Have water flow out of the cooking compartment using the drainage gate valve (see burnt oil drainage procedure).
When these operations have been done successfully, close the drainage gate valve.

Carefully dry all exposed surfaces with a non-abrasive cloth.

Put the heating coil back in the horizontal position (Fig. 14).

If necessary, repeat the operations described above for a new cleaning cycle.



Cleaning for prolonged deactivation

When the appliance remains idle for a long time, perform all the described daily cleaning procedures.

When the operations are over, protect the parts more exposed to oxidation doing as follows.
Therefore:

- Use lukewarm water with a bit of soap to clean the parts;
- Rinse the parts thoroughly, without using pressurised and/or direct water jets;
- Dry the surfaces carefully using non-abrasive material;
- Pass over all the stainless steel surfaces using a non-abrasive cloth slightly moistened with Vaseline to create a protective coating.

Air out the appliances and rooms regularly.

Fig. 1

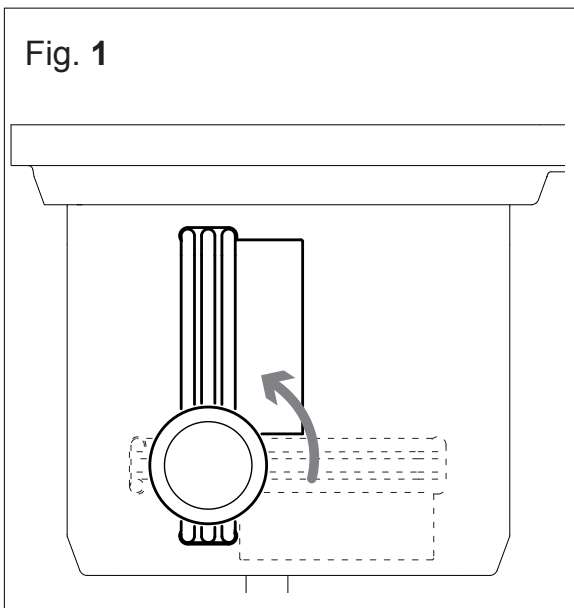
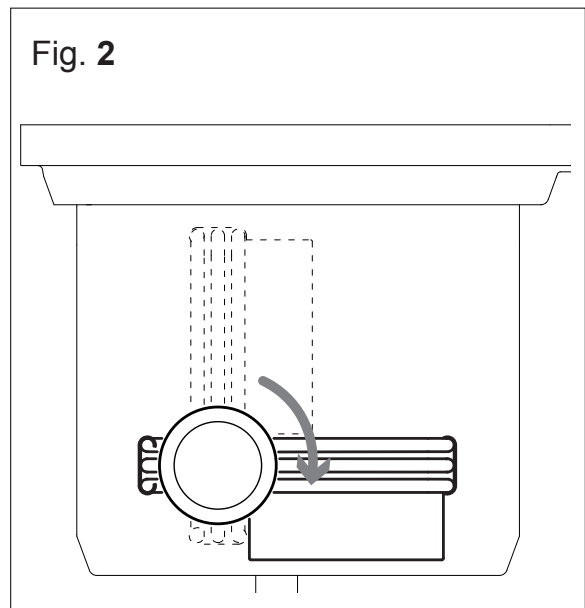

Fig. 2



4. ROUTINE MAINTENANCE

Summarised table: qualification - operation - frequency



“Generic” Operator

Person authorised and in charge of appliance operation with active guards and capable of performing simple tasks.



“Homogeneous” Operator

Learned operator, authorized to carry out the handling, transport, installation, maintenance, repair and demolition of the equipment.

	OPERATION	FREQUENCY
	Cleaning at commissioning	Upon arrival after installation
	Appliance cleaning	Daily
	Cleaning parts in contact with foodstuff	Daily
	Flue cleaning	Yearly
	Checking thermostat	Upon arrival after installation - Yearly
	Checking microswitch	Upon arrival after installation - Yearly
	Checking supply cable	Upon arrival after installation - Yearly
	Cleaning container and oil filter	If necessary

	If the supply cable should be damaged, contact authorized customer service for replacement
	Should a problem occur, the generic operator performs the first search and, if qualified, eliminates the cause of the problem and restores the appliance correct operation.
	If the problem cannot be resolved, turn the appliance off, disconnect it from the electrical mains and shut all the supply valves. Then contact authorized customer service.
	The authorized maintenance technician intervenes when the generic operator was not able to pinpoint the cause of the problem, or whenever restoration of correct operation of the appliance entails executing operations for which the generic operator is not qualified.

4. ROUTINE MAINTENANCE

Troubleshooting



Notes! Whenever the appliance does not work properly, try to solve the less serious problems using this table.

FAULT	POSSIBLE CAUSE	OPERATION
The appliance does not turn on.	<ul style="list-style-type: none"> The master switch is not connected. The residual current device or circuit breaker has tripped. 	<ul style="list-style-type: none"> Connect the master switch. Restore the residual current device and/or circuit breaker.
The cooking compartment is stained.	<ul style="list-style-type: none"> Quality of the water. Ineffective detergent. Insufficient rinsing. 	<ul style="list-style-type: none"> Filter the water (see water softener). Use the recommended detergent. Rinse once again.
The light indicators do not turn on.	<ul style="list-style-type: none"> The master switch is not connected. The residual current device or circuit breaker has tripped 	<ul style="list-style-type: none"> Connect the master switch Restore the residual current device and/or circuit breaker
The fryer does not heats	<ul style="list-style-type: none"> No power supply Safety thermostat Heating element broken Contactora switch broken Working thermostat broken Heating element not positioned correctly Heating element microswitch broken 	<ul style="list-style-type: none"> Check power supply inlet Check status of safety thermostat Replace heating element Replace the contactora switch Replace the working thermostat Put the heating element in the correctly position Replace microswitch
The fryer don't cooks correctly	<ul style="list-style-type: none"> Heating element broken Contactora switch broken 	<ul style="list-style-type: none"> Check the heating element by multimeter clamp. If it is broken replace this. Replace the contactora switch



Notes! If the problem cannot be resolved, turn the appliance off, and shut all the supply valves. Then contact authorized customer service.



5. WASTE DISPOSAL

Deactivation and scrapping of appliance



OBLIGATION OF DISPOSING OF MATERIALS USING THE LEGISLATIVE PROCEDURE IN FORCE IN THE COUNTRY WHERE THE APPLIANCE IS SCRAPPED.

In compliance with Directives (see n. 0.1 Section), relating to the reduction of use of hazardous substances in electrical and electronic equipment, as well as waste disposal. The symbol of the barred waste bin carried on the appliance or its packaging indicates that the product at the end of its useful life it must be disposed of separately from other waste.

Differentiated waste collection of this appliance at the end of its life is organised and implemented by the manufacturer. The user who wishes to get rid of this appliance must contact the manufacturer and follow the instructions received to separately dispose of the appliance at the end of its life. An appropriate collection and dispatching of exhausted appliances to environmentally compatible recycling, treatment and disposal plants helps to prevent damaging effects on health and environment and also guarantees that the component parts of exhausted appliances are effectively recycled or reused. Holders of exhausted appliances who dispose of them illegally will be prosecuted.



Specialised personnel is in charge of deactivation and scrapping of the appliance.

Waste disposal



During operation and maintenance, do not disperse pollutants (oils, grease, etc.) into the environment and perform differentiated waste disposal depending on the composition of the different materials and in compliance with relevant laws in force.

Illegal waste disposal will be prosecuted by laws in force in the territory where the violation has been ascertained.



REMARKS
