

05/2018

Mod: E9/F18A4

Production code: BBEF498



Diamond
catering equipment

**INSTALLATION INSTRUCTIONS
FOR THE USE OF THE SPECIALISED TECHNICIAN**

EN

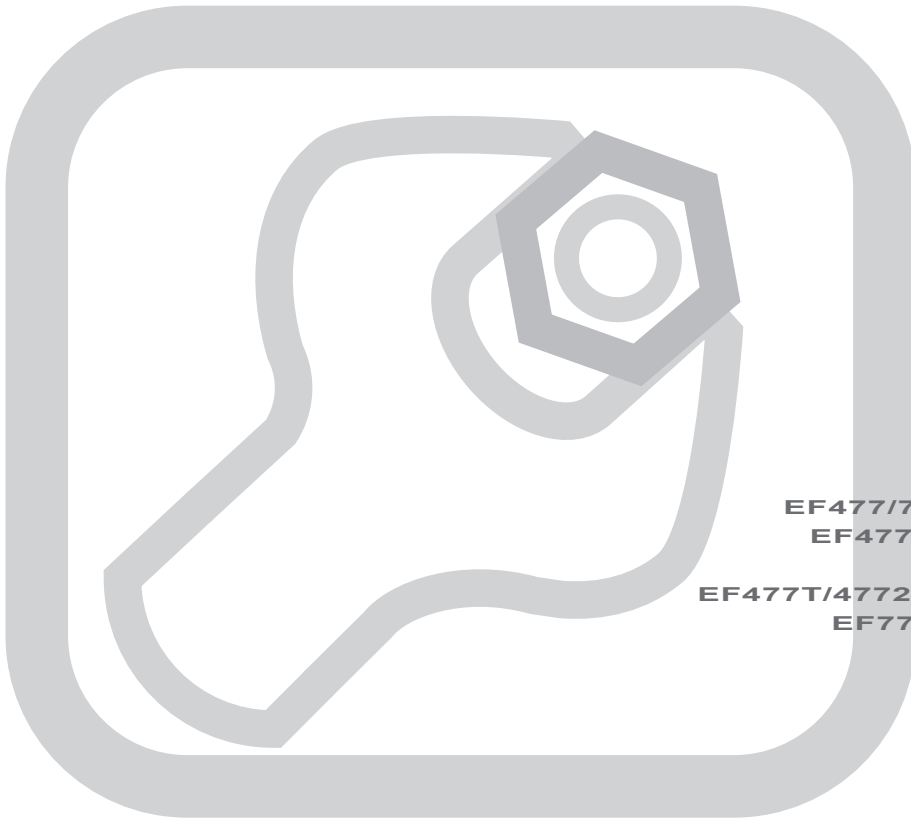

**EF477/777
EF4772V**

**EF477T/4772VT
EF777T**

**EF408/908(L)
EF4082V**

**EF498/998(L)
EF4982V
EF498T/998T**

07/2016 - Ed. 3 - Cod.n° 183870



**ELEKTRYCZNY
ELECTRIC
ELEKTRISCH
ELECTRIQUE
ELÉCTRICO**



0.

IDENTIFICAZIONE DOCUMENTO - DOCUMENT IDENTIFICATION
 IDENTIFICATION DU DOCUMENT - IDENTIFICACIÓN DEL DOCUMENTO
 DOKUMENT-KENNDATEN - IDENTIFICAÇÃO DO DOCUMENTO
 IDENTYFIKACJA DOKUMENTU - DOCUMENTIDENTIFICATIE - ИНФОРМАЦИЯ О ДОКУМЕНТА

CODICE DEL DOCUMENTO - DOCUMENT CODE - CODE DU DOCUMENT CÓDIGO DEL DOCUMENTO - DOKUMENTNUMMER - CÓDIGO DO DOCUMENTO KOD DOKUMENTU - DOCUMENTCODE - КОД ДОКУМЕНТА:	N° 183870
EDIZIONE - EDITION - EDITION - EDICIÓN - AUSGABE - EDIÇÃO - WYDANIE - EDITIE - РЕДАКЦИЯ:	2016 Rev. 3 - 07/2016
TIPO DI DOCUMENTO - TYPE OF DOCUMENT - TYPE DE DOCUMENT - TIPO DE DOCUMENTO - DOKUMENTTYP - TIPO DE DOCUMENTO - TYP DOKUMENTU - DOCUMENTTYPE - ТИП ДОКУМЕНТА:	M.U.
MODELLO - MODEL - MODÈLE - MODELO - MODELL - МОДЕЛЬ:	ELETTRICO - ELECTRIC - ELECTRIQUE ELÉCTRICO - ELEKTRISCH - ELÉTRICO ELEKTRYCZNY - ЭЛЕКТРИЧЕСКАЯ
ANNO DI COSTRUZIONE - YEAR OF CONSTRUCTION - ANNÉE DE FABRICATION - AÑO DE FABRICACIÓN - HERSTELLUNGSJAHR - ANO DE FABRICO - ROK PRODUKCJI - BOUWJAAR - ГОД ИЗГОТОВЛЕНИЯ:	2016
CONFORMITÀ - CONFORMITY - CONFORMITÉ - DECLARACIÓN DE CONFORMIDAD - KONFORMITÄT - CONFORMIDADE - ZGODNOŚĆ - CONFORMITEIT - НОРМАТИВНОЕ СООТВЕТСТВИЕ:	CE

Targa di identificazione - Identification plate - Plaque d'identification - Placa de identificación - Typenschild - Placa de identificação - Tabliczka identyfikacyjna - Identificatielabel - Паспортная табличка.

- A - Indirizzo Costruttore - Manufacturer's Address - Adresse du Fabricant - Dirección del fabricante - Anschrift des Herstellers - Endereço do fabricante - Adres Producenta - Adres Fabrikant - Адрес изготовителя.
 B - Apparechiatura Elettrica - Electrical Appliance - Appareil Electrique - Sistema eléctrico - Elektrogerät - Aparelhamagem elétrica - Urządzenie Elektryczne - Elektrisch Apparaat - Электрооборудование.
 C - Apparechiatura Gas - Gas Appliance - Appareil à Gaz - Sistema de gas - Gasgerät - Aparelhamagem a gás - Urządzenie Gazowe - Gasapparaat - Газовое оборудование.

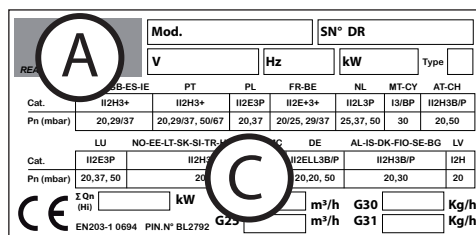
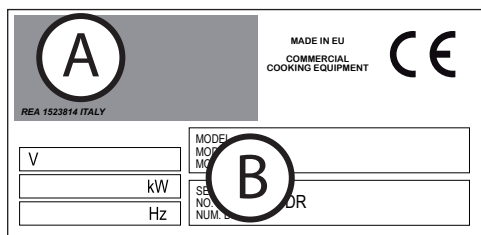

0.1

QUADRO NORMATIVO DI RIFERIMENTO - STANDARDS OF REFERENCE TABLEAU NORMATIF DE REFERENCE - MARCO REGLAMENTARIO DE REFERENCIA - REFERENZNORMEN - QUADRO NORMATIVO DE REFERÊNCIA - RAMY REGULACYJNE ODNIESIENIA - TABEL MET NORMREFERENTIES - СПРАВОЧНЫЕ НОРМАТИВНЫЕ СТАНДАРТЫ

Direttiva Gas 2009/142/CE (ex-90/396/CEE) Gas Directive 2009/142 EC (ex-90/396/EEC) Directive Gaz 2009/142 CE (ex-90/396/CEE) Directiva sobre los aparatos de gas 2009/142/CE (ex-90/396/CEE) Gas-Richtlinie 2009/142/EG (ex-90/396/EWG) Diretiva Gás 2009/142/CE (ex-90/396/CEE) Dyrektywa o urządzeniach spalających paliwa gazowe 2009/142/WE (ex-90/396/EWG) Gasrichtlijn 2009/142/EG (ex-90/396/EEG) Директива по газовому оборудованию 2009/142/EC (ранее-90/396/EEC) Gassdirektivet 2009/142/CE (tidligere-90/396/CEE) Gas direktiv 2009/142/EG (ex-90/396/CEE)	Direttiva Bassa Tensione 2014/35/EU Low Voltage Directive 2014/35/EU Directive Basse Tension 2014/35/EU Directiva de baja tensión 2014/35/EU Niederspannungsrichtlinie 2014/35/EU Diretiva baixa tensão 2014/35/EU Dyrektywa Niskonapięciowa 2014/35/EU Richtlijn lage Spanning 2014/35/EU Директива 2014/35/EU по низковольтному оборудованию Lavspenningsdirektivet 2014/35/EU Lågspänningsdirektivet 2014/35/EU	Direttiva EMC 2014/30/EU EMC Directive 2014/30/EU Directive EMC 2014/30/EU Directiva EMC 2014/30/EU EMV-Richtlinie 2014/30/EU Diretiva EMC 2014/30/EU Dyrektywa EMC 2014/30/EU EMC Richtlijn 2014/30/EU Директива 2014/30/EU по электромагнитной совместимости EMC Direktivet 2014/30/EU EMC direktivet 2014/30/EU	Smaltimento Apparecchiature elettriche ed elettroniche Waste electrical and electronic equipment Démantèlement des Appareils électriques et électroniques Desguace de equipos eléctricos y electrónicos Entsorgung elektrischer und elektronischer Altgeräte Eliminação das aparelhagens elétricas e eletrônicas Utylizacja odpadów elektrycznych i elektronicznych Afgedankte Elektrische en Elektronische Apparaten Утилизация электрического и электронного оборудования Avhending av elektriske og elektroniske apparater Avtvitting av elektriske og elektroniske produkter
GAS-GÁS-GAZ GAZOWY-GAZ ELETTRICO ELECTRIC ELECTRIQUE ELÉCTRICO ELEKTRISCH ELÉTRICO ELEKTRYCZNY ЭЛЕКТРИЧЕСКАЯ ELEKTRISK	EN 62233:2008; EN 60335-2-37:2002 + A1:2008 + A11:2012	EN 55014-1:2006 + A1:2009 + A2:2011 EN55014-2:1997 + A1:2001 + A2:2008 EN61000-3-2:2006 + A1:2009 + A2:2009 EN61000-3-3:2008	DIRETTIVA 2011/65/EU (ROHS II) DIRETTIVA 2012/19/EU (WEEE)

0. DOCUMENT IDENTIFICATION

0.1 STANDARDS OF REFERENCE

1. INFORMATION FOR OPERATORS

Foreword - Purpose of document - How to read the document
Keeping the document - Addressees - Operator training program
Pre-arrangements depending on customer - Contents of supply - Intended use
Allowed operational and environmental conditions - Test inspection and warranty

2. GENERAL SAFETY INFORMATION

Description of pictograms - General safety indications - Tasks and qualifications -
Working areas and dangerous areas - Equipment necessary for installation - Indications
concerning residual risks - Operating mode in case of smell of gas in the room

3. POSITIONING AND HANDLING

Obligations/Prohibitions/Advice/Recommendations
Safe handling
Foreword - Handling/Transport - Storage - Removal of
protection materials - Levelling and fixing - "Series" assembly - Insertion of
"optional" terminal

4. CONNECTION TO ENERGY SOURCES (see TECHNICAL DATA)

5. INSTRUCTIONS FOR USE

Location of main control components
Knobs, keys and indicator light modes and functions
Description of stop modes - Stoppage due to faulty operations - Emergency stop
- Stoppage during a work phase - Commissioning -
Daily activation - Daily and prolonged deactivation

6. MAINTENANCE

Obligations/Prohibitions/Advice/Recommendations
Cleaning at commissioning
Cleaning for prolonged deactivation
Qualification/Operation/Frequency
Troubleshooting

7. WASTE DISPOSAL

Deactivation and scrapping of appliance

8. TECHNICAL DATA (from page A)

TECHNICAL DATA PAGE - INSTALLATION DIAGRAMS - ELECTRICAL WIRING DIA-
GRAMS

1. INFORMATION FOR OPERATORS

Foreword

This document has been drawn up in the mother language of the manufacturer (Italian). The information it contains is for the sole use of the operator authorised to use the appliance in question.

Operators must be trained concerning all aspects regarding functioning and safety. Special safety prescriptions (Obligations-Prohibitions-Dangers) are carried in a specific chapter concerning these issues. This document cannot be handed over to third parties to take vision of it without written consent by the manufacturer. The text cannot be used in other publications without the written consent of the manufacturer. The use of: Figures/Images/Drawings/Layouts inside the document, is purely indicative and can undergo variations. The manufacturer reserves the right to modify it, without being obliged to communicate his acts.

Purpose of the document

Every type of interaction between the operator and the appliance during its entire life cycle has been carefully assessed both during designing and while drawing up this document. We therefore hope that this documentation can help to maintain the characteristic efficiency of the appliance. By strictly keeping to the indications it contains, the risk of injuries while working and/or of economical damage is limited to a minimum.

How to read the document

The document is divided into chapters which gather by topics all the information required to use the appliance in a risk-free way. Each chapter is divided into paragraphs; each paragraph can have titled clarifications with subtitles and descriptions.

Keeping the document

This document is an integral part of the initial supply. It must therefore be kept and used appropriately during the entire operational life of the appliance.

Addressees

This document is structured for the exclusive use of the homogeneous operator (Specialised and authorised technician), that is to say, for all the operators authorised to handle, transport, install, service, repair and scrap the appliance. The homogeneous operators should read the service manual, in order to achieve an overall view of the information.

Operator training program

Upon specific demand by the user, a training course can be held for operators in charge of using the appliance, following the modalities provided in the order confirmation.

Depending on the demand, preparation courses can be held at the site of manufacturer or of the user, for:

- Homogeneous operator in charge of electric/electronic maintenance (Specialised technician).
- Homogeneous operator in charge of mechanical maintenance (Specialised technician).
- Generic operator for simple operations (Operator - Final user).

Pre-arrangements depending on customer

Unless different contractual agreements were made, the following normally depend on the customer:

- setting up the rooms (including masonry work, foundations or channelling that could be requested);
- smooth, slip-proof floor;
- pre-arrangement of installation place and installation of equipment respecting the dimensions indicated in the layout (foundation plan);
- pre-arrangement of auxiliary services adequate for requirements of the system (electrical mains, waterworks, gas network, drainage system);
- pre-arrangement of electrical system in compliance with regulatory provisions in force in the place of installation;
- sufficient lighting, in compliance with standards in force in the place of installation;
- safety devices upstream and downstream the energy supply line (residual current devices, equipotential earthing systems, safety valves, etc.) foreseen by legislation in force in the country of installation;
- earthing system in compliance with standards in force;
- pre-arrangement of a water softening system, if needed (see technical details).

Contents of the supply

Appliance

Lid/s

Metallic rack/s

Rack support grid

Pipes and/or wires for connections to energy sources (only when indicated in work order).

The supply may vary depending on the order.

1. INFORMATION FOR OPERATORS

Intended use

Original instructions. This device is intended for professional use. The use of the appliance treated in this document must be considered "Proper Use" if used for cooking or regeneration of goods intended for alimentary use; any other use is to be considered "Improper use" and therefore dangerous. The appliance must be used according to the foreseen conditions stated in the contract within the prescribed capacity limits mentioned in the respective paragraphs.

Allowed operational and environmental conditions

The appliance has been designed to operate only inside rooms within the prescribed technical and capacity limits. The following indications must be observed in order to attain ideal operation and safe work conditions. The appliance must be installed in a suitable place, namely, one which allows normal running, routine and extraordinary maintenance operations. The operating area for maintenance must be set up in such a way that the safety of the operator is not endangered.

The room must also be provided with the features required for installation, such as:

- maximum relative humidity: 80%;
- minimum cooling water temperature > + 10 °C;
- the floor must be anti-slip, and the positioned appliance must lay perfectly flat;
- the room must be equipped with a ventilation system and lighting as prescribed by standards in force in the country of the user;
- the room must be set up for draining grey water, and must have switches and gate valves which cut all types of supply upstream the appliance when needed;
- The walls/surfaces around the appliance must be fireproof and/or insulated against possible heat sources.s.

Test inspection and warranty

Testing: the equipment has been tested by the manufacturer during the assembly stages at the site of the production plant. All certificates relating to the testing carried out we will be delivered to the customer.

Warranty: The guarantee is of 12 months from invoice date and it covers the faulty parts only. Carriage and installation charges are for the buyer's account. Electric components, accessories as well as other removable parts are not covered by the guarantee.

Labor costs relating to the intervention of authorized by the manufacturer at the customer's premises, for removal of defects under warranty are charged to the dealer, except in cases where the nature of the defect is such that it can be easily removed on site by the customer.

Excluded are all tools and supplies, possibly supplied by the manufacturer together with the machines.

Damage occurred in transit or due to incorrect installation or maintenance can't be considered. Guarantee is not transferable and replacement of parts and appliance is at the final discretion of our company. The manufacturer is responsible for the device in its original setting.

The manufacturer declines all responsibility for improper use, for damages caused as a result of operations not covered in this manual or not authorized in advance by the manufacturer.

The warranty terminates in case of:



















- Damage caused by transportation and/or handling. Should this occur, the customer must inform the dealer and carrier via fax or RR and must write what has happened on the copies of the transportation documents. The specialised technician installing the appliance will assess whether it can be installed depending on the damage. The warranty also terminates in the presence of:
- Damage caused by incorrect installation;
- Damage caused by parts worn due to improper use;
- Damage caused by use of not recommended or non-original spare parts;
- Damage caused by incorrect maintenance and/or lack of maintenance;
- Damage caused by failure to comply with the procedures described in this document.

Authorisation

Authorisation refers to the permission to operate an activity intrinsic to the appliance.

















Authorisation is given to anyone who is responsible for the appliance (manufacturer, purchaser, signer, dealer and/or location owner).

Description of pictograms





	<p>Danger signals</p> <p>Immediate danger situations that could cause serious injuries or death. Potentially dangerous situation that could cause serious injuries or death.</p>
	High voltage! Caution! Danger of death! Any noncompliance can cause serious injuries or death
	Danger of high temperatures, any noncompliance can cause serious injuries or death.
	Danger of spillage of materials at high temperatures, any noncompliance can cause serious injuries or death.
	Danger of limb crushing during movement and/or positioning, any noncompliance can cause serious injuries or death.
	<p>Prohibition signals</p> <p>Prohibition for unauthorised personnel to perform any interventions (included children, disabled and persons with limited physical, sensory and mental skills). Prohibition for generic operators to perform operations (maintenance and/or other) reserved for qualified and authorised technicians. The homogeneous operator can not carry out any type of operation (installation, maintenance and/or other) without having first examined the whole documentation.</p>
     	<p>Obligation signals</p> <p>Obligation to read the instructions before performing any intervention.</p> <p>Obligation to interrupt the electrical input upstream the appliance each time it's necessary to operate in safety conditions.</p> <p>Obligation to use goggles.</p> <p>Obligation to use protective gloves.</p> <p>Obligation to use protective helmet.</p> <p>Obligation to use accident prevention shoes.</p>
	<p>Other signals</p> <p>Indications on how performing the correct procedure, any noncompliance can cause a dangerous situation.</p>
	Advices and suggestions on how performing a correct use procedure
	<p>“Homogeneous” Operator (Qualified Technician)</p> <p>Learned operator, authorized to carry out the handling, transport, installation, maintenance, repair and demolition of the equipment.</p>
	<p>“Generic” operator (Operator with limited responsibilities and tasks)</p> <p>Person authorised and in charge of appliance operation with active guards and capable of performing simple tasks.</p>
	Earthing symbol
	Symbol for connection to Equipotential system
	Obligation to keep to the in force standards concerning waste disposal.

2. GENERAL AND SAFETY INFORMATION

General safety indications

	Each technical modification affects the machine functioning or safety, therefore, it must be carried out by the manufacturer technical staff or by technicians who has been formally authorized by the same manufacturer. Otherwise, the manufacturer refuses all responsibility concerning modifications or damages which could be consequently rise.
	On arrival of the delivery, check the integrity of the appliance and of its components (eg. Supply cable), before use, if any fault should arise, do not start the appliance and contact the nearest customer service.
	Before performing the connections check the technical data mentioned on the appliance plate, as well as the technical data mentioned on this manual.
	On the supply lines (Electrical-Water-Gas) upstream the machine, install interlock devices which cut out the supply each time the user must operate in safe conditions.
	Connect the appliance, in order, to the waterworks and to the drainage system, then to the gas network, make sure there are no leaks then go on with the connections to the electric network.
	The appliance has not been designed for the operation in an explosive atmosphere, therefore it mustn't absolutely be installed and used in such environments.
	Position the whole structure following the installation characteristics mentioned in the specific chapters of this manual.
	Note! <ul style="list-style-type: none"> • The equipment has not been designed for an embedding installation. • The equipment must operate in thoroughly ventilated rooms. • The equipment drains must be free (not obstructed or blocked by foreign matters).
	The gas appliance must be placed under a suction hood, which system must be endowed with the technical features complying with the standards in force in the country of the user.
	Once the equipment has been connected to the energy and drain sources, it must remain static (not movable) in the area which has been foreseen for use and maintenance. An improper connection may give rise to a dangerous situation.
	If necessary, for the connection to the electrical line use a flexible cable which characteristics comply with those of the cable with rubber insulation, model H07RN-F. The supply voltage supported by the cable, with the appliance on, must not diverge from the rated voltage value $\pm 15\%$, mentioned at the bottom of the technical data table.
	The equipment must be included in an "Equipotential" earth unload system.
	The appliance drain must be conveyed into the grey water drainage system, with a "spigot and socket" pipe with no trap.
	The equipment must be used only for the indicated purposes. Any other use must be considered as "IMPROPER" and therefore the manufacturer refuses all responsibility for possible consequent damages to persons or things.
	Special safety prescriptions (Obligations-Prohibitions-Dangers) are mentioned in detail in a specific chapter concerning these issues.
	Do not obstruct the heat extraction and/or dissipation openings.



Tasks and qualifications required for the operators

	<p>“Homogeneous” Operator (SKILLED OPERATOR) Learned operator, authorized to carry out the handling, transport, installation, maintenance, repair and demolition of the equipment.</p>
	<p>The homogeneous operator can not carry out any type of operation (installation, maintenance and/or other) without having first examined the whole documentation.</p>
	<p>The information reported in this manual must be used only by the qualified technical operator, authorized to perform: handling, installation and maintenance of the equipments in hand.</p>
	<p>The technical operators must be trained in all the aspects concerning functioning and safety. The technical operators must interact following all required safety rules.</p>

Working zones and dangerous zones

The following classification has been established for a better definition of the intervention field and of the corresponding working zones:

- **Dangerous zones:** any zone inside and/or near a machine, where the presence of an exposed person represents a risk for the safety and health of said person.
- **Exposed person:** any person completely or partly in a dangerous zone.

	<p>During operation, keep a minimum distance from the appliance, in order not to jeopardize the operator safety if anything unexpected should happen.</p>
	<p>The generic operator must have gone through this document. Such operator is not authorized in any case to perform check or maintenance operations pertaining to skilled and authorized personnel (Homogeneous operator).</p>

The dangerous zones are also:

- All the working areas inside the machine
- All the areas protected by special protection and safety systems, such as photocells photoelectric barriers, protection panel, interlocked doors, protection guard.
- All the zoned inside control units, electrical panels and connector blocks.
- All zones around the functioning machine, when the minimum safety distances are not complied with.

Equipment necessary for installation





For the correct execution of the installation operations, the authorized technical operator must provide himself with the tools provided, such as:

3 and 8 mm slot screwdriver	Gas leaks detector.	Tools for gas use (pipes, gaskets etc.)
Fixed spanners from 7 mm to 24 mm	Tools for electrical use (cables, terminal boards, industrial outlets etc.)	Tools for water use (pipes, gaskets etc.)
Electrician shears	Self-locking pliers	Kit for gas type changeover, supplied from the manufacturer

	<p>In addition to the tools indicated, a device for the equipment lifting will also be necessary: it must comply with all the in force standards concerning the hoisting equipments.</p>
---	--

Indications concerning residual risks

Though the rules for "good manufacturing practice" and the provisions of law which regulate manufacturing and marketing of the product have been implemented, "residual risks" still remain which, due to the very nature of the appliance, could not be eliminated. These risks include:

	Residual risk of electrocution: This risk remains when intervening on live electrical and/or electronic devices.
	Residual risk of burning: This risk remains when unintentionally coming into contact with materials at high temperatures.
	Residual risk of burning for spillage of material: This risk remains when unintentionally coming into contact with materials being spilled at high temperatures. Containers too full of liquids, or solids, changing their state while they are being heated (from a solid state to a liquid state), if incorrectly used, can cause burning. During processing phase, the containers being used must be placed on clearly visible levels.
	Residual risk of limb crushing: This risk remains when unintentionally coming into contact with any part being positioned, transported, stored, assembled.

Operating mode in case of smell of gas in the room



In case of gas smell in the room, immediately execute with the utmost haste the procedures described below.

- Immediately interrupt gas supply (Close the network, detail A).
- Immediately aerate the room.
- Do not operate any electrical device in the room (Detail B-C-D).
- Do not operate any electrical device that could produce sparks or flames (Detail B-C-D).
- To inform the institutions in charge (electric company and/or fire brigade), use a communication means placed outside the room where gas smell has been noticed.



B

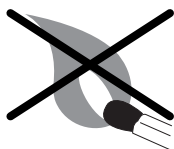







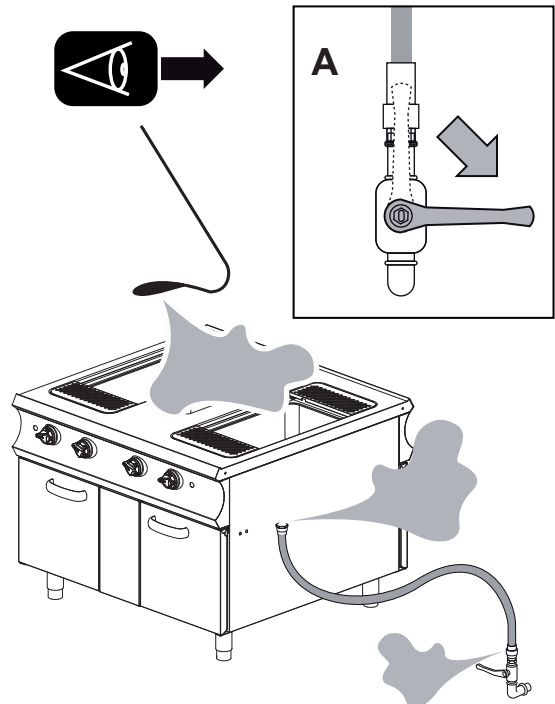

C













D



Obligations - Prohibitions - Suggestions - Recommendations

	On reception, open the packaging and make sure that the appliance and accessories have not been damaged during transportation. If damage is found, report it promptly to the carrier and do not install the appliance. Contact qualified and authorised personnel to report the problem detected. The manufacturer is not liable for damage caused during transportation
	Prohibition for unauthorised personnel to perform any interventions (included children, disabled and persons with limited physical, sensory and mental skills).
	Read the instructions before performing any type of operation.
	Wear a protection outfit, suitable to the operations to be performed. For what concerns the personal protection devices, the European Community has issued the directives which the operators must follow.
	Absolute prohibition to damage or remove the plates and pictograms applied to the machine.
	Interrupt every form of supply (electrical - gas - water) upstream the machine each time it's necessary to operate in safety conditions.
	Do not leave objects or inflammable material next to the machine.
	Special safety prescriptions (Obligations-Prohibitions-Dangers) are mentioned in detail in a specific chapter concerning these issues.

Safe handling

	The noncompliance with the instructions described below exposes the operator to the danger of serious injuries.
	Installation operations must be performed by qualified and authorized technical operators, in keeping with the in force standards concerning thus issue, using the suitable materials described here.
	Wear personal protection clothing, which must comply with the requirements of the EC directive concerning the individual protection devices.
	The operator authorized to appliance handling and installation operations must arrange, if necessary, a "safety plan", in order to safeguard the safety of the persons involved in the operations. Moreover, the operator must keep to and strictly and scrupulously apply the laws and standards concerning mobile yards.
	Make sure that the employed lifting means have a carrying capacity suitable to the loads to be lifted and that they are kept in good conditions.
	Perform handling operations using lifting means with a carrying capacity suitable to the appliance weight, increased by the 20%.
	Follow the indications written on the package and/or on the same appliance before going on with the handling.
	Check the barycentre of the load before lifting the appliance.
	Lift the appliance from the floor, enough to allow its handling.
	Do not wait or pass under the equipment while it is being lifted and handled.

3. POSITIONING AND HANDLING

Foreword

Depending on the cases, the appliance is shipped in the following configuration:

1. Blocked on the wooden base, with lining in a material suitable for packaging (detail A).

The type of packaging is chosen according to transport distance, to the customer prescriptions and to how long the appliance will remain in the package.

The following data will be applied on the package:

- destination
- possible codes
- safety pictograms
- instruction pictograms



The machines can be transported with two means:

with truck

with container.

The same type of package is foreseen in both cases.

Handling - Transport

	The packed appliance must be positioned in order to keep to the indications given in the pictograms and in the writings on the package outer wrap.
	Do not wait or pass under the equipment while it is being lifted and handled. The noncompliance with these instructions exposes the operator to the danger of serious injuries.



- Position the hoisting equipment: take care to the barycentre of the load to be lifted (detail B - C).
- Lift the appliance enough to allow its handling.
- Position the appliance in its standing place.

Storage

Material storage methods must envisage pallets, containers, conveyors, vehicles, lifting tools and devices, which can prevent any damage caused by vibrations, bumps, abrasions, corrosions, temperature or any other possible conditions.

The stored parts must be checked periodically to identify any possible damage.

Package removal



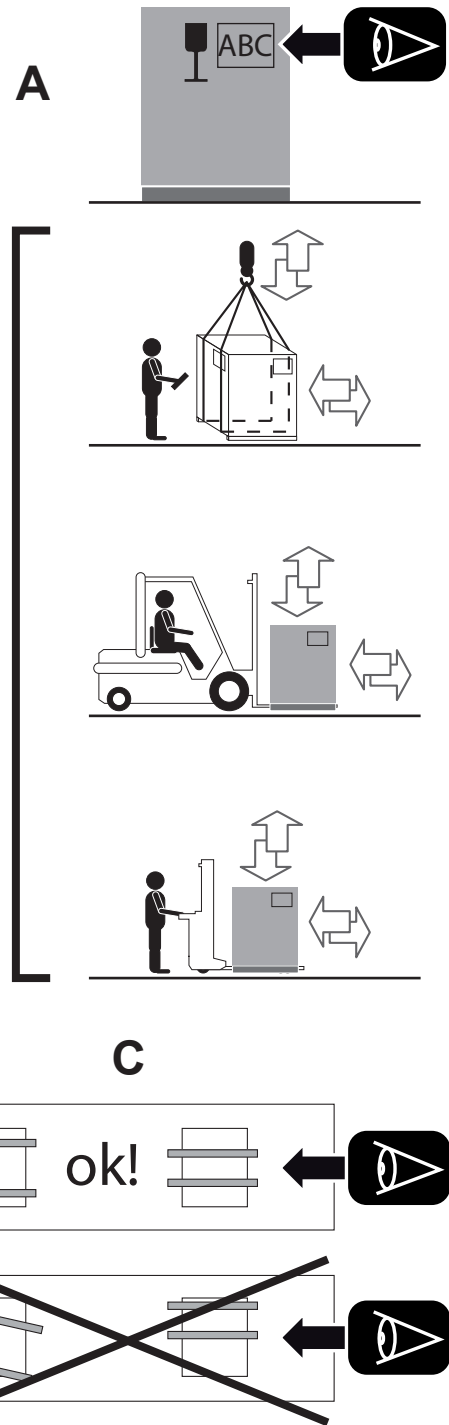

	The addressee is in charge of the disposal of the packing materials, which must be eliminated according to the laws in force in the appliance installation country.
	<ol style="list-style-type: none"> 1. Remove the protection angle bars, first the upper and then the lateral ones; 2. Removed the protective material used for the package. 3. Lift the appliance at the necessary height and remove the base; 4. Position the appliance on the floor. 5. Remove the means used to lift the appliance. 6. Clear the operating area from all the material that has been removed.
	Once the packaged has been removed, the appliance must appear free of tampering, dents or other defects. Otherwise, immediately inform the assistance service.



Removal of protection materials

The outer surfaces of the appliance are protected by a coating of adhesive film, which must be manually removed once positioning phase is over.

Clean the appliance manually removing all the material used to protect its parts.

	Make sure not to damage the stainless steel surfaces, and remember especially not to use corrosive products, abrasive material or sharp tools.
	Do not clean the appliance with pressurized and/or direct water jets.
	Do not use aggressive materials such as solvents to clean the appliance. Carefully read the indications on the label of the detergent products being used, wear a protective equipment suitable to the operations to be carried out (See protection means indicated on the label of the packaging)
	Rinse the surfaces with tap water and dry them with an absorbent cloth or other non abrasive material.

Levelling and fixing

Position in the working area (see allowed operational and environmental conditions), with the different equipments already made suitable.

Levelling and fixing envisage: the equipment adjustment as an individual independent unit or, if foreseen, its fixing in a "series".

	The series positioning sequence for the different equipments is strictly connected to the purchaser (user) requirements.
---	--

Position a level on the structure (detail D).

Adjust the levelling feet (detail E) according to the indications shown by the level.

	The appliance is perfectly levelled when level and feet are adjusted on the same width and depth of the appliance.
---	--

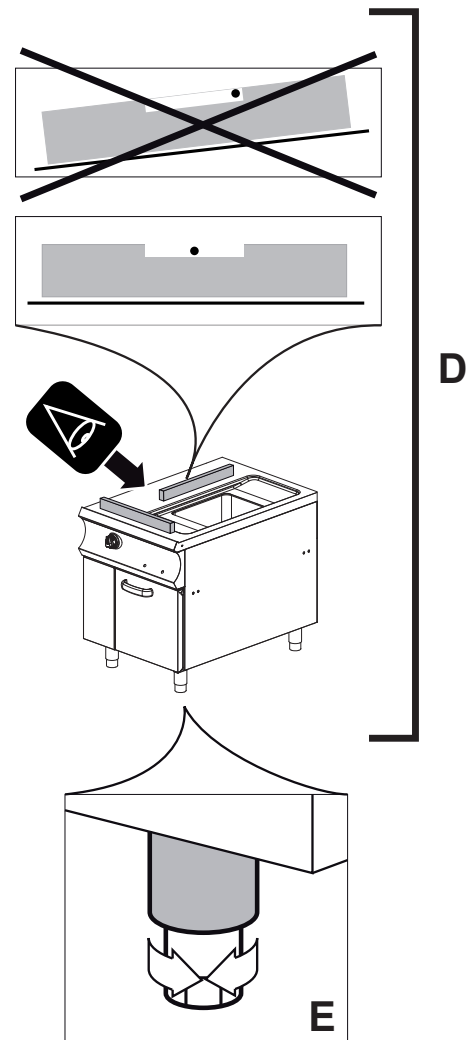

“Series” assembly

Remove the knobs and unscrew the screws for the fixing of the panel on both appliances (detail F).



The minimum distance of the appliance from the wall must be 10 cm, if this should be lower, the walls immediately close to the appliance should be insulated with fire-retardant and/or insulating treatments.

Place the equipments in order to make their sides perfectly adhere (detail G).

Carry out the appliance levelling as previously described (detail E).

Introduce the fixing screws in their housings and block the two structures with the locking nuts (detail H1).

Introduce the supplied fixing cap between the two appliances (detail H2)

If necessary, repeat levelling and fixing operation sequence for the remaining equipments.

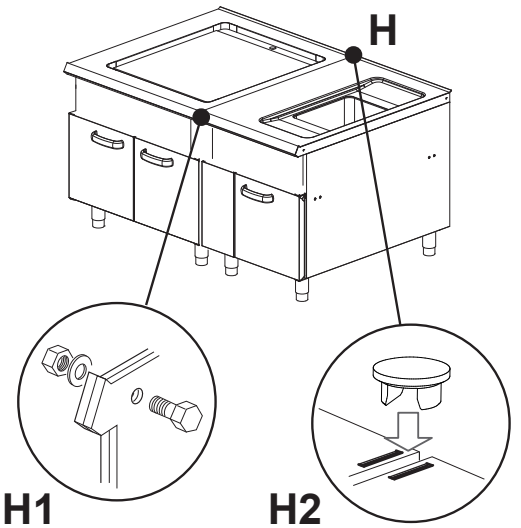
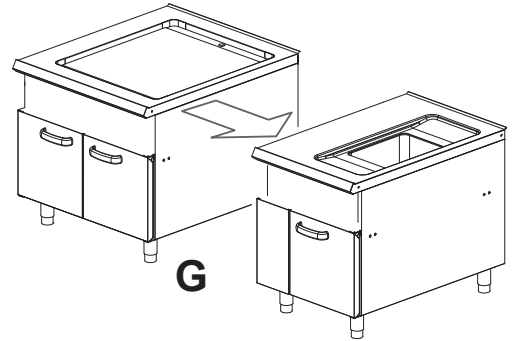
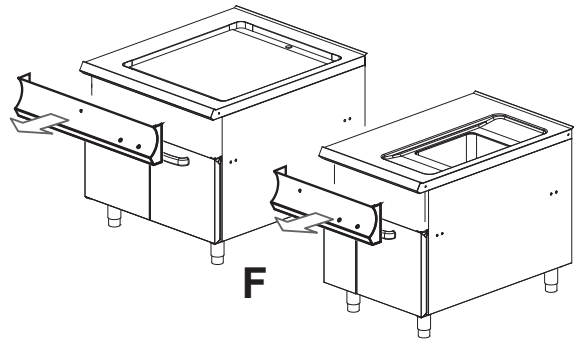
**Introduction of terminal (optional)**

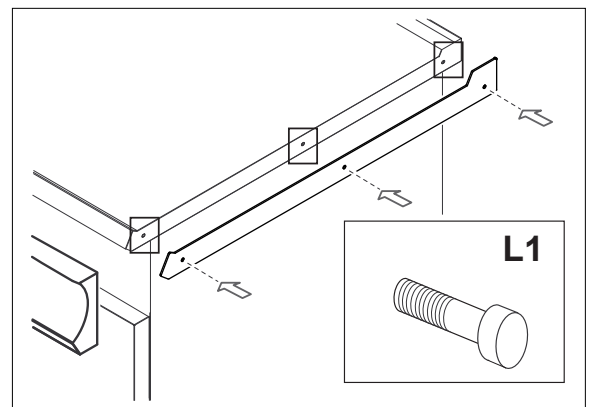

In order to introduce the terminal, position it and fix it with the equipped screws provided (detail L1).

Once the described operations have been carried out, position again the panels and knobs of the different appliances in the respective housings.



5. INSTRUCTIONS FOR USE

Description of stop modes

	In stoppage conditions caused by faults and emergencies, in the event of imminent danger, it is mandatory to close all the locking devices on the supply lines upstream the appliance (Electrical-Water-Gas).
	The drawing illustrates the various positions the knobs take on during an emergency stop (A1-B1-C1-D1-E1) and stoppage during a working phase (A2-B2-C2-D2-E2).

Stoppage due to faulty operations

Safety component

Standard supply with following models:

- Fryer (present on all models)
- Tilting Pan (present on all models)
- Pot (present on all models)
- Pasta cooker (present on all models)
- Stove (present on all models with electric oven. Only for 900-980: present on all models with standard electric oven)
- Frytop present on all electric models (only for 900-980)
- Lava stone (not present)
- Bain-marie (not present)
- Solid top (only for 900-980: present on all models with standard gas oven)
- Induction (present on all models)

Stop: In situations or circumstances which can be dangerous, a safety thermostat is triggered, automatically stopping heat generation. The production cycle is interrupted until the cause of the fault is resolved.

Restarting: After the problem that triggered the safety thermostat is resolved, the authorised technician can restart the appliance by means of the specific controls.

Emergency stop

In situations or circumstances which can be dangerous, turn the knob to “Zero” depending on the model (A-B-C-D-E-1). See knobs, keys and indicator light modes and functions.

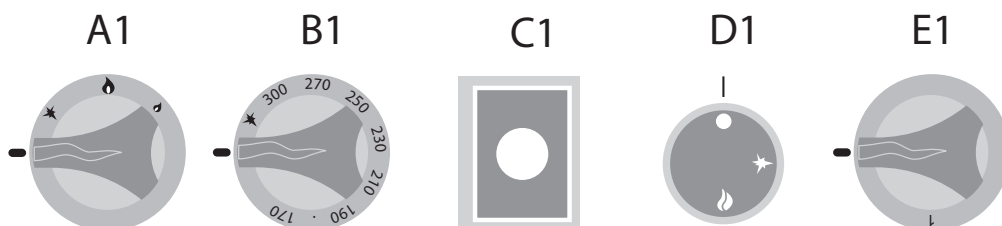

Stoppage during a work phase

In situations or circumstances which require temporary stop of heat generation, act as follows:

- Gas Appliance: Turn the knobs to the piezoelectric position (A-B-C-2), the pilot flame remains lit as the gas flow in the burner is not interrupted.
 - Electric Appliance: Turn the knobs “D2-E2” to “Zero” to stop heat generation.
- (See knobs, keys and indicator light modes and functions).

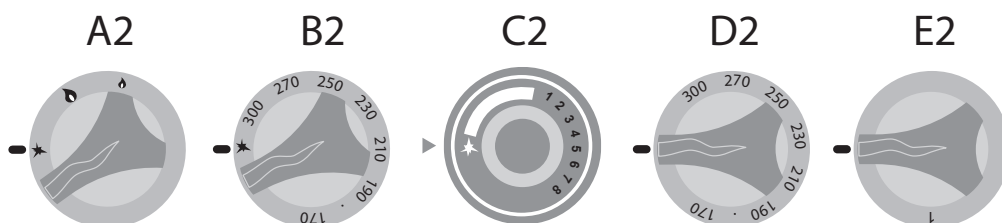

5. INSTRUCTIONS FOR USE

Commissioning



When commissioning the appliance and when starting it after a prolonged stop, it must be thoroughly cleaned to eliminate all residue of extraneous material (See Routine Maintenance).

When the operations have been successfully performed, go on with the ordinary use of the appliance, see "Daily activation".

Daily activation"

1. Open the network locks upstream the appliance (Gas - Water - Electric).
2. Make sure that the water drain (if present) is not clogged.
3. Make sure that the room local exhaust system works properly
4. Check the cleanliness and hygiene of the appliance.

When the operations have been successfully performed, go on with "Start for cooking" operations, described in the use manual: operating instructions issued for each appliance.

Daily deactivation

Perform the operations according to the procedure described for each appliance.
Once the above mentioned operations for each appliance are over, it is necessary to:

1. Close the network locks upstream the appliance (Gas - Water - Electric).
2. Make sure that the drain cocks (if present) are positioned to "Close".
3. Check the cleanliness and hygiene of the appliance see "Cleaning".

Prolonged deactivation in time

In the event of prolonged inactivity, carry out all the procedures described for the daily deactivation and protect the parts mostly exposed to oxidation as described in "Maintenance" chapter.



If the appliance is connected to a flue, the exhaust pipe must be cleaned according to that foreseen by specific regulatory provisions of the country (contact your installer for information).



To make sure that the appliance is in perfect technical conditions, have it serviced at least once a year by an authorised technician of the assistance service.

6. MAINTENANCE

	<p>Obligations - Prohibitions - Suggestions - Recommendations</p>
	<p>Before performing any of the cleaning operations described hereafter, the operator must have had a look at the whole document, carefully read:</p> <ul style="list-style-type: none"> • General and safety warnings • Indications concerning residual risks • Safety for a correct use • Safety for the appliance cleaning
	<p>Prohibition for unauthorised personnel to perform any interventions (included children, disabled and persons with limited physical, sensory and mental skills). Prohibition for generic operators to perform operations reserved for qualified and authorised technicians.</p>
	<p>If the appliance is connected to a flue, the exhaust pipe must be cleaned according to what foreseen by specific regulatory provisions of the country (Contact your installer for information).</p>
	<p>To make sure that the appliance is in perfect technical conditions, have it serviced at least once a year by an authorised technician of the assistance service.</p>
	<p>Filth deposit built up near heat sources can burn during normal use of the appliance and create dangerous situations. The appliance must be cleaned regularly and every incrustation and/or food deposit removed.</p>
	<p>In order to eliminate every residual of moisture on the electrical plates, to ward off any early wear, once routine cleaning operations are over, switch the appliance on, make it work for approximately 10' and switch it off.</p>
	<p>Whenever you access the cooking area, always remember that the danger of being burnt persists. It is therefore mandatory to take appropriate measures for personal protection.</p>
	<p>Disconnect electrical power upstream the appliance whenever you need to work in safe conditions to perform cleaning or maintenance.</p>
	<p>Wear a protection outfit, suitable to the operations to be performed. For what concerns the personal protection devices, the European Community has issued the directives which the operators must follow.</p>
	<p>The appliance is used to prepare food products. Keep the appliance and the surrounding area constantly clean. Failure to keep the appliance in ideal hygienic conditions could cause it to deteriorate quickly and create dangerous situations.</p>
	<p>The chemical effect of salt and/or vinegar or other acid substances can in the long run cause the inside of the cooking compartment to corrode during cooking. At the end of the cooking cycle of such substances, the appliance must be washed thoroughly with detergent, abundantly rinsed and carefully dried.</p>
	<p>The liquid detergent for cleaning the cooking compartment must have certain chemical features: pH higher than 12, without chlorides/ammonia, viscosity and density similar to water. Use non-aggressive products for cleaning the inside and outside of the appliance (Use detergents on the market for cleaning steel, glass and enamel).</p>
	<p>Carefully read the indications on the label of the products being used, wear a protective equipment suitable to the operations to be carried out (See protection means indicated on the label of the packaging)</p>
	<p>Make sure not to damage the stainless steel surfaces, and remember especially not to use corrosive products, abrasive material or sharp tools.</p>
	<p>Do not clean the appliance with pressurized and/or direct water jets.</p>
	<p>Rinse the surfaces with tap water and dry them with an absorbent cloth or other non abrasive material.</p>
	<p>In the event of prolonged inactivity, besides disconnecting the supply lines, you must thoroughly clean all the inside and outside parts of the appliance.</p>



Cleaning at commissioning

Remove the outer protective film by hand and thoroughly clean all the outside parts of the appliance.

At the end of the operations described for cleaning the outside parts, carefully clean the cooking compartment.

Depending on the type of appliance, remove: grids, pans, racks, wall baffle, or any other object that can be removed from the cooking compartment.

Use a standard sprayer to apply the detergent liquid on the whole surface of the cooking compartment, and using a non-abrasive sponge, clean the entire surface thoroughly by hand.

When finished, rinse the cooking compartment abundantly with tap water.

Drain away the liquid with detergent and/or other impurities in the special drain collecting hole (Present only in some models).

When the operations have been successfully performed, carefully dry the cooking compartment with a non-abrasive cloth. If necessary, repeat the operations described above for a new cleaning cycle.

Clean with detergent and tap water also the parts that have been removed (grids, pans, racks, wall baffles, or any other object that can be removed from the cooking compartment). Carefully dry also the components that have been removed.

Once these operations are over, position the removed parts in the housings provided.



When repositioning the parts removed, do not invert burners and wall baffles' positions.



In order to eliminate every residual of moisture on the electrical plates, to ward off any early wear, once routine cleaning operations are over, switch the appliance on, make it work for approximately 10' and switch it off.



Cleaning for prolonged deactivation

In the event of prolonged inactivity, carry out all the procedures described in "Daily deactivation", and for each appliance, apply the procedure described in "Maintenance" (See cleaning).

When the operations are over, protect the parts mostly exposed to oxidation doing as follows.

Therefore:

- Use lukewarm water with a bit of soap to clean the parts;
- Rinse the parts thoroughly, without using pressurised and/or direct water jets.
- Dry the surfaces carefully using non-abrasive material;
- Go over all the stainless steel surfaces with a non-abrasive cloth slightly moistened with Vaseline to create a protective coating.

For appliances with doors and rubber gaskets, leave the door slightly ajar to let it air out and spread protective talcum powder on the rubber gasket surfaces.



- Air out the appliances and rooms regularly.

6. MAINTENANCE

Qualification - Operation - Frequency



“Generic” Operator

Person authorised and in charge of appliance operation with active guards and capable of performing simple tasks.



“Homogeneous” Operator

Learned operator, authorized to carry out the handling, transport, installation, maintenance, repair and demolition of the equipment.

	OPERATION	FREQUENCY
	Cleaning at commissioning	Upon arrival after installation
	Appliance cleaning	Daily
	Cleaning parts in contact with foodstuff	Daily
	Flue cleaning	Yearly
	Checking thermostat	Upon arrival after installation - Yearly
	Checking microswitch	Upon arrival after installation - Yearly
	Checking exhaust gases	Upon arrival after installation - Yearly
	Checking supply cable	Upon arrival after installation - Yearly
	Oil filter cleaning (Only for fryers)	Weekly
	Top cleaning (chrome-plated, cast iron)	Daily

	If the supply cable should be damaged, contact authorized customer service for replacement
	Should a problem occur, the generic operator performs the first search and, if qualified, eliminates the cause of the problem and restores the appliance correct operation.
	If the problem cannot be resolved, turn the appliance off, disconnect it from the electrical mains and shut all the supply valves. Then contact authorized customer service.
	The authorized maintenance technician intervenes when the generic operator was not able to pinpoint the cause of the problem, or whenever restoration of correct operation of the appliance entails executing operations for which the generic operator is not qualified.

6. MAINTENANCE

Troubleshooting



Notes! Whenever the appliance does not work properly, try to solve the less serious problems using this table.

FAULT	POSSIBLE CAUSE	OPERATION
The appliance does not turn on.	<ul style="list-style-type: none">• The master switch is not connected.• The residual current device or circuit breaker has tripped.	<ul style="list-style-type: none">• Connect the master switch.• Restore the residual current device and/or circuit breaker.
The inner walls of the tank are covered with limestone.	The water is too hard; the softener is finished.	<ul style="list-style-type: none">• Connect the appliance to a water softener.• Regenerate the water softener.• Descale the cooking compartment.
The cooking compartment is stained.	<ul style="list-style-type: none">• Quality of the water.• Ineffective detergent.• Insufficient rinsing.	<ul style="list-style-type: none">• Filter the water (see water softener).• Use the recommended detergent.• Rinse once again.
The gas appliance does not turn on.	<ul style="list-style-type: none">• Gas cock closed.• Air in the piping	<ul style="list-style-type: none">• Open the gas cock• Repeat switching on operations
The light indicators do not turn on.	<ul style="list-style-type: none">• The master switch is not connected.• The residual current device or circuit breaker has tripped	<ul style="list-style-type: none">• Connect the master switch• Restore the residual current device and/or circuit breaker



Notes! If the problem cannot be resolved, turn the appliance off, and shut all the supply valves. Then contact authorized customer service.



Deactivation and scrapping of appliance



OBLIGATION OF DISPOSING OF MATERIALS USING THE LEGISLATIVE PROCEDURE IN FORCE IN THE COUNTRY WHERE THE APPLIANCE IS SCRAPPED

In compliance with Directives (see Section n. 0.1) relating to the reduction of use of hazardous substances in electrical and electronic equipment, as well as waste disposal. The symbol of the barred waste bin carried on the appliance or its packaging indicates that the product at the end of its useful life must be disposed of separately from other waste.

Differentiated waste collection of this appliance at the end of its life is organised and implemented by the manufacturer. The user who wishes to get rid of this appliance must contact the manufacturer and follow the instructions received to separately dispose of the appliance at the end of its life.

An appropriate collection and dispatching of exhausted appliances to environmentally compatible recycling, treatment and disposal plants helps to prevent damaging effects on health and environment and also guarantees that the component parts of exhausted appliances are effectively recycled and/or reused. Holders of exhausted appliances who dispose of them illegally will be prosecuted according to the in force standards.



Appliance deactivation and scrapping are entrusted to skilled electrical and mechanical personnel, who must wear the individual protection devices provided, such as clothing with characteristics suitable to the operations to be performed, protective gloves, accident prevention shoes, helmets and goggles.



Before starting disassembly, create a space around the appliance, wide and tidy enough to allow the operator movements in safety conditions.

It is necessary to:

- Clear the electric network.
- Disconnect the appliance from the electric network.
- Remove the appliance exit electrical cables.
- Close water entry cock (network valve) from the waterworks.
- Disconnect and remove the waterworks' pipes from the appliance.
- Disconnect and remove the pipe for grey water drain exit.



After disassembly, there could be a wet area around the appliance, therefore, dry these zones before proceeding further.

When the operating area has been reset through this procedure, it is necessary to:

- Remove the protection panels.
- Strip down the appliance in its main parts.
- Separate the appliance parts according to their typology (eg. metallic materials, electric materials etc.) and dispatch them to waste separation centres.

1.1 ELECTRIC HEATED DEEPFAT FRYERS

MODEL	DIMENSIONS mm.		CHIPS MAX AMOUNT FOR TANK kg.	TOTAL POWER ABSPORTION kW	NET WEIGHT kg.
	EXTERNAL L x P x A/A max.	TANK Ltr.			
EF477T	400 x 735 x 250/330	12	1	9	30
EF4772VT	400 x 735 x 250/330	6 + 6	0,5	10,5	35
EF777T	700 x 735 x 250/330	12 + 12	1+1	9 + 9	45
EF477	400 x 735 x 850/925	13	1,2	9	60
EF4772V	400 x 735 x 850/925	7 + 7	0,6	10,5	60
EF777	700 x 735 x 850/925	13 + 13	1,2+1,2	9 + 9	80

MODEL	DIMENSIONS IN mm.		TANK CAPACITY lt.	TOTAL INPUT POWER* kW	NET WEIGHT kg.
	external W x D x H	tank W x D x H			
EF4...	400 x 900 x 850	300 x 400 x 200	18	16	56
EF9...	800 x 900 x 850	300 x 400 x 200	18+18	32	91
EF4...2V	400 x 900 x 850	300 x 400 x 200	8+8	10,5	56
EF4/9...L	400/800 x 900 x 850	300 x 400 x 200	21/21+21	20/40	58/91

Tab. 1

*SUPPLY VOLTAGE: 3N AC 400 V; 3 AC 230 V; 1N AC 230 V 50/60 Hz.

N.B.: The input power with 3N AC 380 V; 3 AC 220 V; 1N AC 220 V 50/60 Hz is approximately 9% lower than the figures given.

The input power with 3N AC 415 V; 3 AC 240 V; 1N AC 240 V 50/60 Hz is approximately 9% higher than the figures given.

1.2 TECHNICAL CHARACTERISTICS

STRUCTURE Frame made of AISI 304 stainless steel, panels and base of stainless steel, mounted on height-adjustable feet.

BASIN made of AISI 304 stainless steel with oil expansion zone.

ELECTRIC THERMOSTAT to control the heating elements (60 ÷ 200°C) for optimum temperature adjustment.

ADDITIONAL SAFETY THERMOSTAT that stops the operation in case of overheating.

“Incoloy” armoured stainless steel **ELECTRICAL RESISTANCES**, submerged in oil, easy to overturn for a thorough cleaning.

PILOT LIGHTS for controlling the operation.

Athermic **CONTROL HANDLES**.

Installation must be performed by qualified persons in accordance with current local regulations.

WARNINGS:

If the oven is installed against a wall, the wall needs to withstand temperatures of 100°C and must be fireproof.

Before proceeding with the installation, remove the protective plastic film and eliminate any adhesive residues by means of a suitable product for cleaning stainless steel.

Install the oven horizontally, correct positioning is obtained by turning the levelling feet.

If the unit is installed on its own, it is advisable to secure it to make its stability safer.

2.2 LAWS, REGULATIONS AND TECHNICAL DIRECTIVES

The following regulations must be observed during installation:

- Current accident and fire regulations.
- The regulations of the electric power supply company.
- Local Health regulations.
- Electrical systems standards.

2.3 PLACE OF INSTALLATION

- The unit should be installed in a room with adequate ventilation.
- Install the unit in compliance with the safety regulations.

2.4 POSITIONING

- The various units may be installed separately or combined with other units in the range.
- This unit is not suitable for encasing.
- The distance from the side walls must be at least 10 cm.; should the distance be less or the material of the walls or floor be flammable, it is vital to install thermal insulation.

2.5 ELECTRICAL CONNECTION

The electrical connection must be made in compliance with CEI standards, only by authorized and skilled personnel. Firstly, check the data given in the technical data table of this manual, on the data plate and in the wiring diagram. The envisaged connection is of the fixed type.

IMPORTANT: A multi-polar mains cut-off device must be provided upstream from each oven, with a contact gap of at least 3 mm., for example:

- a manual switch of suitable capacity, equipped with fuses
- circuit breaker with relevant miniature circuit breakers.

2.6 EARTHING

It is vital to earth the oven. Connect the terminals marked by the symbols () positioned on the line-in terminal block to an efficient grounding complying with the regulations in force.

SPECIFIC WARNINGS

The electrical safety of this unit is assured only when it is connected correctly to an effective earthing system as stated in the current electrical safety standards; the manufacturer accepts no liability if these safety standards are not met.

It is necessary to verify this fundamental safety requisite and, in case of doubt, ask for the system to be tested thoroughly by professionally qualified personnel.

The manufacturer cannot be deemed responsible for any damage caused by failure to earth the system.

CAUTION: NEVER CUT THE EARTH WIRE (yellow-green).

2.7 EQUIPOTENTIAL SYSTEM

The unit must be included in an equipotential system whose efficiency must be checked according to the standards in force. The screw marked by the "Equipotential" label is near the terminal block on the base of models with an oven and on the back of the other models.

2.8 POWER SUPPLY CABLE

The unit is delivered fitted for one of the following voltages:

3N AC 380...415 V; 3 AC 220...240 V; 1N AC 220...240 V 50/60 Hz.

The specifications of the power supply connection flexible cable must match or be superior to those of the cable with rubber insulation H07RN-F. Introduce the cable through the cable clamp and secure it firmly. During operation, the power supply voltage should not differ from the voltage rating by +/-10%.

To access the terminal block in order to connect the unit to a supply mains with different characteristics to the ones envisaged, or to replace the supply cable, you need to:

- remove the front panel (top or top + cabinet)
- connect the supply cable to the terminal block according to need, following the instructions given on the label located near the terminal block and in this booklet.

2.9 ADVICE FOR THE INSTALLER

Start the unit following the user instructions and explain its operation to the user with the aid of the instructions booklet, illustrating any construction and/or functional modifications.

Leave the instructions booklet with the user, explaining that it must be used for future reference.

2.10 CONNECTIONS TO THE VARIOUS ELECTRIC MAINS

<p>3N AC 380...415 V 50/60 Hz Elements 230 V</p>		<p>PE (Earth) yellow - green N (NP) blue L₃ (T) black L₂ (S) black L₁ (R) brown</p>
<p>2N AC 380...415 V 50/60 Hz Elements 230 V</p>		<p>PE (Earth) yellow - green N (NP) blue L₂ (S) black L₁ (R) brown</p>
<p>3AC 220...240 V 50/60 Hz Elements 230 V</p>		<p>PE (Earth) yellow - green L₃ (T) blue L₂ (S) black L₁ (R) brown</p>
<p>1N AC 220...240 V 50/60 Hz Elements 230 V</p>		<p>PE (Earth) yellow - greSen N (NP) blue L₁ (R) brown</p>

Tab. 2

The electrical connection plate is placed near the terminal board.

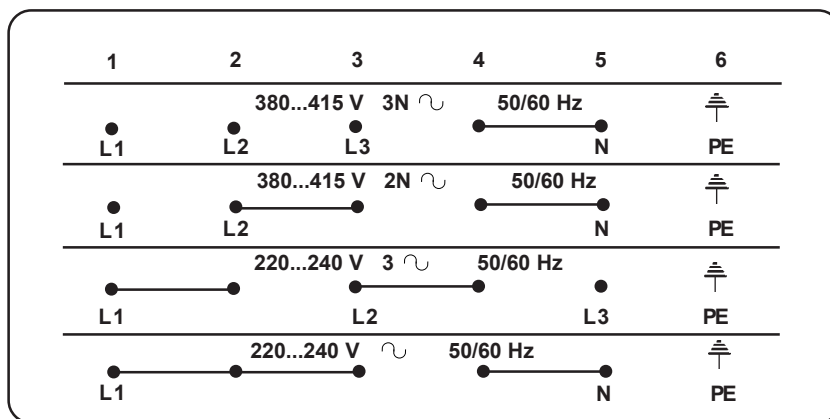

MODEL	EF477 EF477T		EF777		EF4772V EF4772VT	
	Max. A/f	Nb. Cables mm ²	Max. A/f	Nb. Cables mm ²	Max. A/f	Nb. Cables mm ²
3N AC 380...415 V 50/60 Hz	13	5 x 1,5	13	5 x 1,5	15,2	5 x 1,5
2N AC 380...415 V 50/60 Hz	19,5	4 x 2,5	26	4 x 2,5	23	4 x 2,5
3 AC 220...240 V 50/60 Hz	22,6	4 x 2,5	22,6	4 x 2,5	26,3	4 x 2,5
AC 220...240 V 50/60 Hz	39	3 x 6	39	3 x 6	45,7	3 x 6
QUANTITY OF POWER SUPPLY CABLES	1		2		1	

MODEL	EF4...		EF9...		EF4...2V	
	Max. A/phase	N° cables mm ²	Max. A/phase	N° cables mm ²	Max. A/phase	N° cables mm ²
3N AC 380...415 V 50/60 Hz	23	5 x 4	46	5 x 4	15	5 x 2,5
2N AC 380...415 V 50/60 Hz	46	4 x 6	69	3 x 10	23	4 x 4
3 AC 220...240 V 50/60 Hz	40	4 x 6	80	3 x 10	26	4 x 4
AC 220...240 V 50/60 Hz	69	3 x 10	139	-	45	4 x 6
NUMBER OF SUPPLY CABLES	1		2		1	

Tab. 3

3.

REPLACING THE MOST IMPORTANT COMPONENTS

The replacements described below should only be performed by an “Authorized Service Centre”.
Before replacing any component, you need to cut off power to the unit with the multi-polar switch.

A) Switch and thermostat

- remove the instrument panel
- undo the screws fastening the component
- remove the thermostat bulb by sliding it off the bulb-holder (only for the thermostat)
- disconnect the wires, following the wiring diagram
- replace the component and reassemble everything, following the wiring diagram
- fit it all back together in reverse order to the above.

B) Heating elements

- remove the instrument panel
- remove the “Segger” flange for locking the heating element
- disconnect the cables, following the wiring diagram and leaving the protection wire till last
- take the bulbs out of their seats
- take the heating assembly out of the basin
- fit it all back together in reverse order to the above.



SCHEMI D'INSTALLAZIONE - INSTALLATION DIAGRAM - SCHEMAS D'INSTALLATION -
INSTALLATIONSPLÄNE - ESQUEMAS DE INSTALACIÓN

EF477 - EF777 - EF4772V

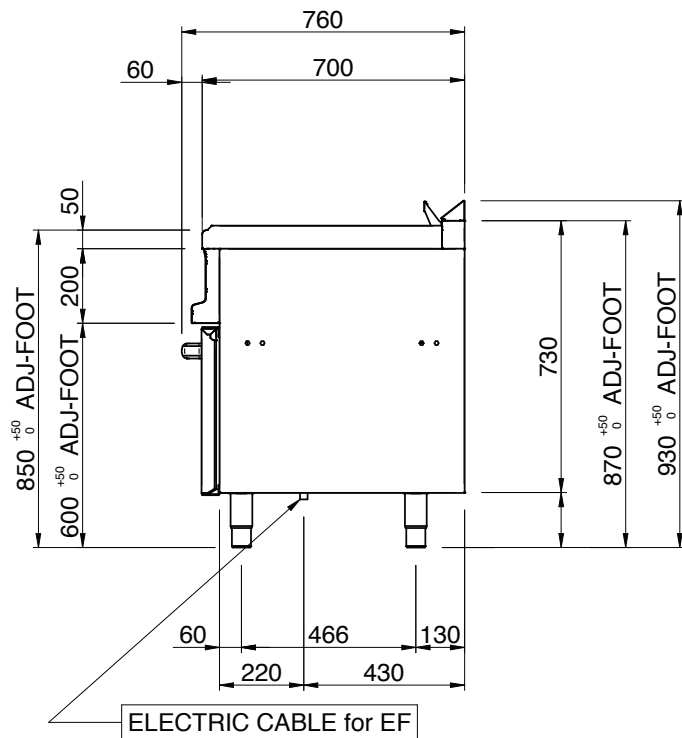
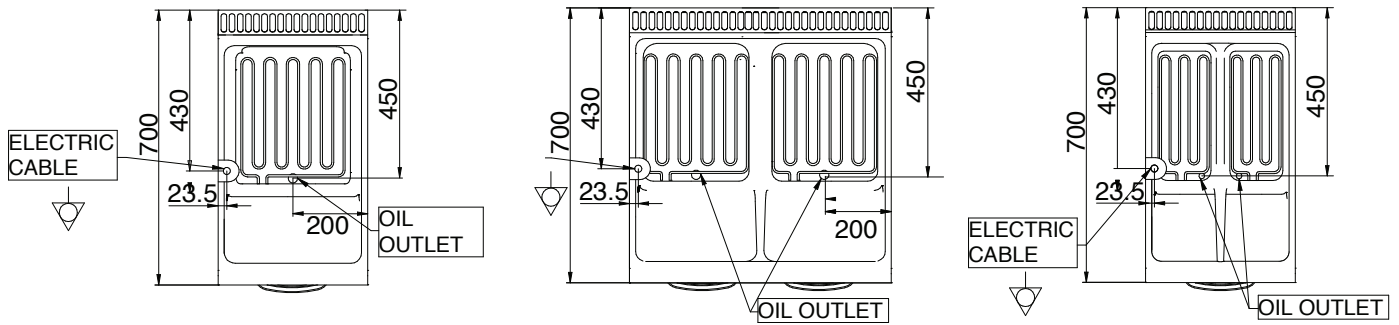
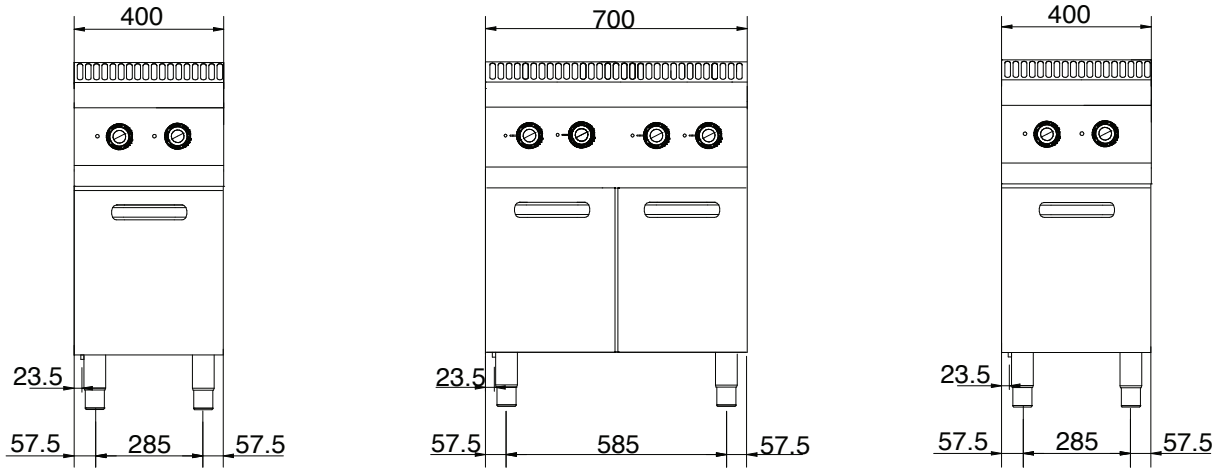



SCHEMI D'INSTALLAZIONE - INSTALLATION DIAGRAM - SCHEMAS D'INSTALLATION -
INSTALLATIONSPLÄNE - ESQUEMAS DE INSTALACIÓN

EF408/498(L) - EF908/998(L) - EF4082V/4982V

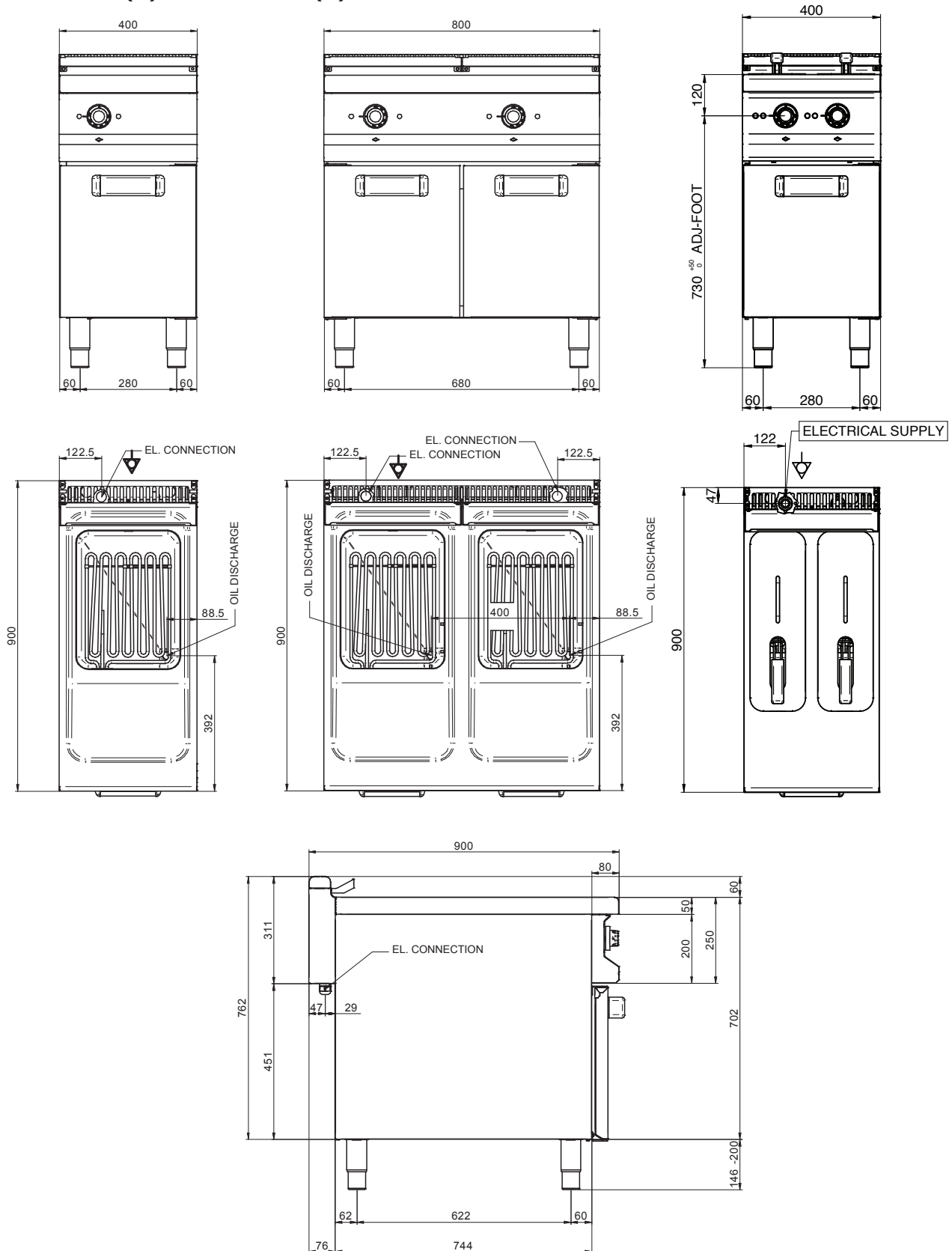



SCHEMA ELETTRICO - WIRING DIAGRAM - SCHÉMA ÉLECTRIQUE - SCHALTPLAN - ESQUEMA ELECTRICO

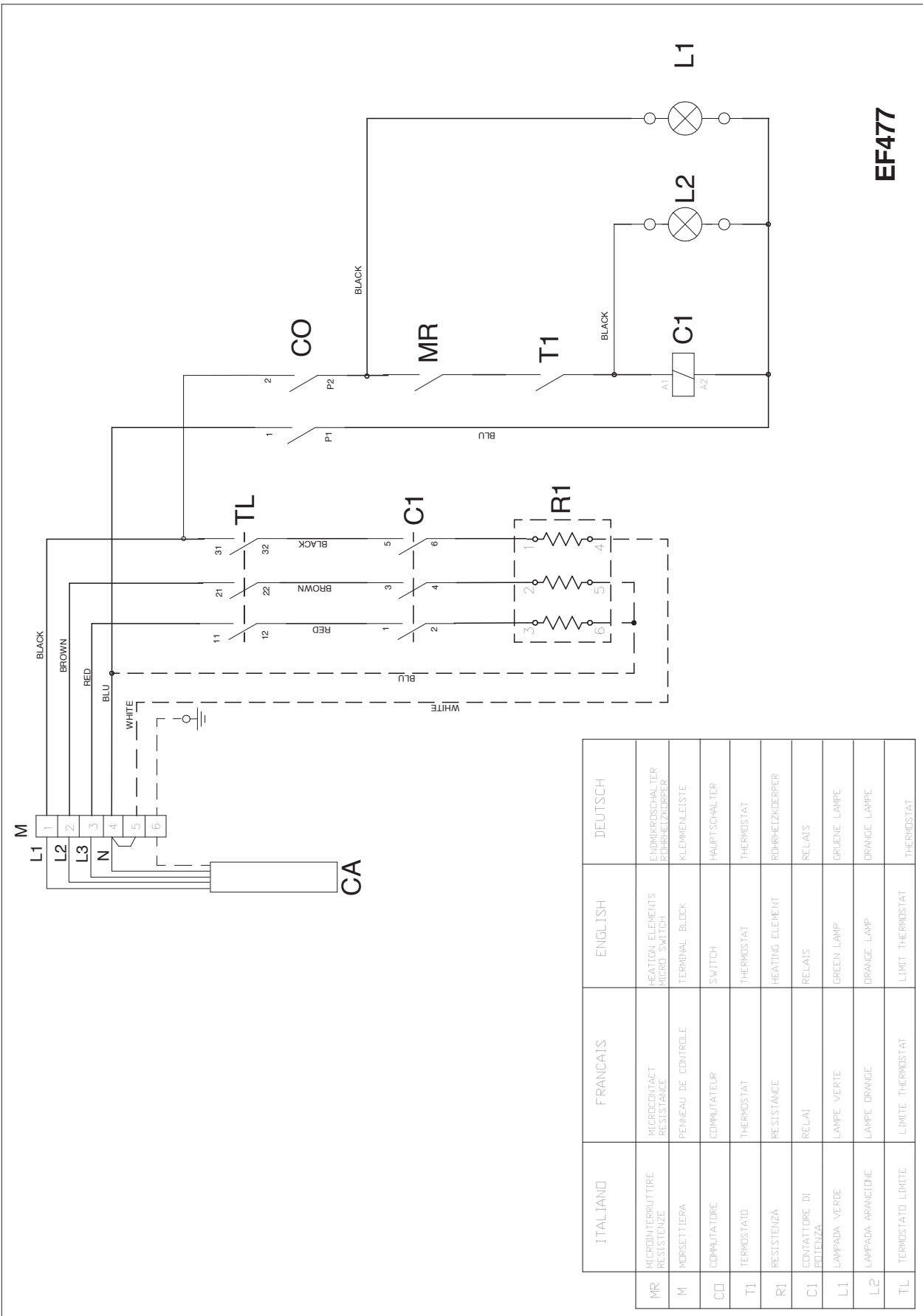

	ITALIANO	FRANCAIS	ENGLISH	DEUTSCH
MR	MICROINTERRUTTORE RESISTENZE	MICROCONTACT RESISTANCE	HEATING ELEMENTS MICRO SWITCH	HEIZUNGSCHALTER ROHRHEIZKLEPPER
M	MORSETTIERA	PENNEAU DE CONTROLLE	TERMINAL BLOCK	KLEMMENLEISTE
CO	COMUTATORE	COMMUTEUR	SWITCH	HAUPTSCHALTER
T1	TERMOSTATO	THERMOSTAT	THERMOSTAT	THERMOSTAT
R1	RESISTENZA	RESISTANCE	HEATING ELEMENT	ROHRHEIZKLEPPER
C1	CONTATTORE DI FORNIZIA	RELAJ	RELAYS	RELAIS
L1	LAMPADA VERDE	LAMPE VERTE	GREEN LAMP	GRUENE LAMPE
L2	LAMPADA ARANCIONE	LAMPE ORANGE	ORANGE LAMP	ORANGE LAMPE
TL	TERMOSTATO LIMITE	LIMITE THERMOSTAT	LIMIT THERMOSTAT	THERMOSTAT

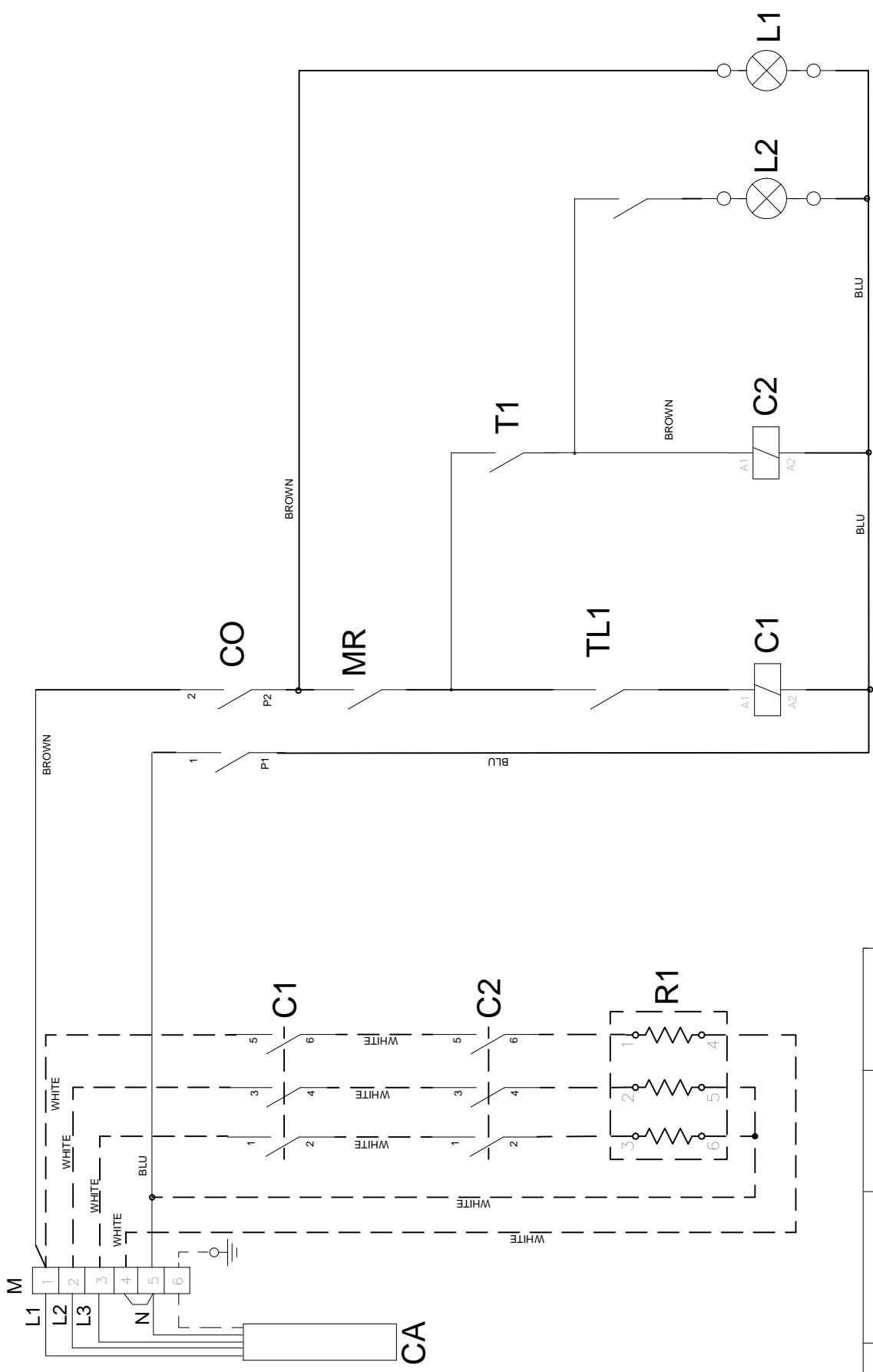

	ITALIANO	FRANCAIS	ENGLISH	DEUTSCH
MR1	MICROINTERRUTTORE RESISTENZA	MICROCONTACT RESISTANCE	HEATING ELEMENTS MICRO SWITCH	ENDKREISCHALTER ROHRHEIZKÖRPER
M	INORSETTIERA	PERNEAU DE CONTROLE	TERMINAL BLOCK	KLEMMENLEISTE
COI	COMUTATORE	COMPOSITEUR	SWITCH	HAUPTSCHALTER
T1	THERMOSTATO	THERMOSTAT	THERMOSTAT	THERMOSTAT
R1	RESISTENZA	RESISTANCE	HEATING ELEMENT	ROHRHEIZKÖRPER
C1	CONTATTORE DI POTENZA	RELAT	RELAIS	RELAIS
L1	LAMPADA VERDE	LAMPE VERTE	GREEN LAMP	GRÜNE LAMPE
L2	LAMPADA ARANCIONE	LAMPE ORANGE	ORANGE LAMP	ORANGE LAMPE
TL1	THERMOSTATO LIMITE	LIMITE THERMOSTAT	LIMIT THERMOSTAT	THERMOSTAT