

MOD: FPE-10/EM

Production code : T ANEMOS 10 E/MC EM









FPE-6/EM

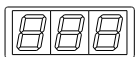

FPE-10/EM

Manual for installation, use and maintenance ■

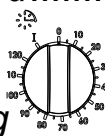
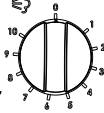
INDEX

1.	INTRODUCTION	5
2.	HOW TO USE THIS MANUAL	6
3.	TECHNICAL SPECIFICATIONS	8
3.1.	Product identification.....	8
3.2.	Meeting directives.....	8
3.3.	Proper and improper machine use.....	8
3.4.	Technical specifications.....	8
4.	INSTALLATION	9
4.1.	Check on delivery.....	9
4.2.	Choice of place of installation.....	9
4.3.	Moving the module.....	10
4.4.	Electrical connection.....	11
4.5.	Connection of steam outlet.....	12
4.6.	Water connection.....	12
4.6.1.	<i>Inlet water</i>	12
4.6.2.	<i>Outlet water</i>	14
4.7.	Checking before starting work.....	15
5.	FUNCTIONING	16
5.1.	Control panel.....	16
5.1.1.	<i>Temperature control</i>	16
5.1.2.	<i>Timer control / Start and Stop cooking</i>	16
5.1.3.	<i>Humidification control</i>	16
5.2.	Control description.....	17
5.2.1.	 °C Chamber temperature display.....	17
5.2.2.	 Button.....	17
5.2.3.	Buttons  and 	17
5.2.4.	"out1" display led green.....	17
5.2.5.	Locking/unlocking the keyboard.....	18
5.2.6.	Timer / Start and Stop cooking 	18
5.2.7.	Humidification regulator 	18
5.2.8.	Humidification light 	18
5.3.	Fault signal.....	19
5.3.1.	<i>Disconnected thermocouple</i>	19
6.	USE	20
6.1.	Preparation for use.....	20

6.2.	Switching on the control panel.....	20
6.3.	Settings	20
6.4.	Start cooking	20
6.5.	Loading the oven	20
6.6.	Use of humidification	21
6.7.	General good cooking indications.....	21
6.8.	Switching off	22
6.9.	Clean.....	22
7.	CLEANING	23
7.1.	Cleaning of the oven cooking chambers.....	23
7.2.	Cleaning outside surfaces	23
8.	MAINTENANCE	25
8.1.	Ordinary maintenance operations.....	25
8.1.1.	<i>Replacing light</i>	25
8.1.2.	<i>Door adjustment</i>	26
8.2.	Fault signals	26
8.3.	Adapting to different supply tensions	26
8.3.1.	<i>Application of the new label.</i>	27
9.	DECOMMISSIONING AND DEMOLITION	28

TECHNICAL ENCLOSURES

- A. Technical Specifications
- B. Connections
- C. Wiring diagrams
- D. Exploded views and list of spare parts

1. INTRODUCTION

The Teorema Ànemos series convection oven has been designed for kitchens with limited space available.

The arrangement of stacked baking pans in a uniformly ventilated environment guarantees excellent baking of confectionery, bread and gastronomy products with a small footprint.

The heating elements are of armoured type so, since they are placed in the centre of steel tubes interposed with ceramic material, they have remarkable qualities of mechanical resistance and insulation from direct contact with external agents, thus guaranteeing an almost unlimited duration and safety from electrical insulation.

Cooking takes place by means of a flow of hot air, heated by the heating elements, which is sent into the cooking chamber. The homogeneity of the air flow allows constant heat distribution, cooking the product evenly all around.

The ovens can be supplied with chambers large enough to contain 6 or 10 baking pans of 60x40 cm.

Particular care has been taken in the construction and the use of stainless steel both in the bodywork and in the cooking chamber guarantees excellent ease of cleaning and a long life even when cooking food containing high percentages of salt, humidity etc

The Manufacturer thanks you for choosing our product. We can assure you that you have made a good choice in putting your trust in a company that has decades of experience in the making of high quality products, never cutting corners and always using the best materials.

2. HOW TO USE THIS MANUAL

⚠ This installation use and maintenance manual must be kept near the equipment in a place where it can be readily consulted. This manual must accompany the equipment in the event of transfer to another owner, as it cannot be considered complete and safe without its documentation.

Note the code and revision number behind the cover. In case of loss you can order another one quoting those numbers.

⚠ This manual consists of a number of chapters. They should all be read by installers and maintenance staff as well as by the final user, both for its **safe use** and to obtain the best results from this product.

Despite this we give here below some useful indications for rapid consultation of the various chapters.

⚠ **The paragraphs marked with this symbol contain essential safety information. They must all be read by installers and the final user, as well as his employees who use the equipment. The Manufacturer assumes no liability for any damage resulting from failure to observe the rules set forth in these paragraphs.**

⊘ The paragraphs marked with this symbol contain important information to avoid any action that could damage the equipment. It is in the user's interest also to read these paragraphs.

Chapter 3 indicates the intended field of use of the equipment and gives the characteristics and all the numbers that may be necessary for its choice, installation and use. It should be used as a reference point to check that the use you intend to make of the equipment does in fact come within those for which it was intended and any time you need to know any value or parameter relating to the equipment.

Chapter 4 contains all the information needed to install the machine. The information is primarily intended for specialised staff but should also be read in advance by the final user so he can arrange the rooms, or have the rooms and necessary plant arranged for the proper working of the equipment.

Chapters 5 and 6 are intended for the user who has to learn how to use the machine. These serve as a guide to the essential operations of turning on, using and turning off of the machine under safe conditions.

Chapter 7 provides all the information required for the cleaning of the equipment i.e. all those operations which have to be carried out by the user in order to ensure that the equipment continues to function safely (especially from the point of view of hygiene) and generally obtains the best result at all times.

Chapter 8 provides the information necessary for proper periodic and extraordinary maintenance, e.g. repairing or replacing parts of the equipment.

 **These maintenance operations must be carried out by specialised staff.**

Chapter 9 provides the information necessary for the decommissioning and demolition.

The technical annexes contain features related to the specific model of oven and all values which may be necessary for the selection, installation and use. This chapter should be used as a point of reference to check that the way the owner intends to use it is in line with the way the machine has been designed to operate and ensure that and ensure that information concerning the precise value of a given measurement or tolerance of the equipment is available whenever necessary.

This chapter also provides a description of the electrical equipment that comes with the machine, the exploded of equipment and a list of spare parts, to facilitate order and replace any damaged parts.

 The Manufacturer reserves the right to update the production series and instruction manuals without the obligation to update the previous production series and previously issued instruction manuals.

3. TECHNICAL SPECIFICATIONS

3.1. Product identification

This manual refers to the T Ànemos 6-10 electric, in the version with electromechanical controls cooking modules.

3.2. Meeting directives

The T Ànemos cooking modules bear the compulsory markings  that certify compliance with the following EU directives:

2014/35/CE Low Tension Directive

2014/30/CE Electromagnetic Compatibility Directive

2006/42/CE Machines Directive

2011/65/CE RoHS 2 Directive

1935/2004/CE Regulation for Equipment intended to come into Contact with Foodstuffs.

3.3. Proper and improper machine use

The T Ànemos cooking modules have been designed to cook fine pastries and cakes for professional use in restaurants, patisseries etc. **by qualified persons only.**

The operations provided for in normal use are the opening and closing of the doors, loading unloading the products on the pans, switching on, adjustment, switching off and the cleaning of the equipment.

3.4. Technical specifications

For technical specifications refer to the following technical annexes at the end of this manual:

- A. Technical Specifications
- B. Connections
- C. Wiring diagrams
- D. Exploded views and list of spare parts

4. INSTALLATION

⚠ WARNING! These installation instructions are for the exclusive use of qualified personnel installing and maintaining electrical equipment. Installation by other not qualified staff may cause damage to the equipment, persons, animals or things.

Where installation of the equipment requires modifications to or additions to the building's electrical plant, whoever carries out these modifications must certify that the works have been carried out according to the regulations in force in the country of installation.

⚠ If damage has occurred do not attempt to use the equipment and contact professionally qualified persons

4.1. Check on delivery

Unless it is agreed otherwise, the products shall be carefully packed with a strong wooden structure and a sheet of bubble pack nylon to protect it from shocks and humidity in transit and shall be delivered to the haulier in the best of condition.

We therefore recommend you check the packaging on delivery to see if there are any signs of damage. If there are such signs, have the fact recorded on the receipt, which must be signed by the driver.

Once the equipment has been unpacked, check for damage.

Also check that all the parts are present, included any non assembled parts. If the equipment is damaged or any parts are missing, bear in mind that the haulier accepts complaints only within 15 days of delivery and that the Manufacturer shall not be liable for any damages suffered by its products during transportation. We shall nevertheless be at your disposal to assist you in presenting your claim.

4.2. Choice of place of installation

The good, safe and long-lasting working of the equipment depends also on the place in which it is installed. It is therefore advisable to carefully assess where it will be installed before it is delivered.

Install the equipment in a dry and easily accessible place, both for its use and for cleaning and maintenance. The surrounding area must be kept free of obstacles. In particular make sure the cooling openings are not obstructed.

It must in any case be installed at least 15 cm from the room's walls or other equipment.

⊘ Placement near other equipment that reaches high temperatures is not recommended. If necessary, ensure a gap of at least 50 cm at the sides and 70 cm at the rear or place an insulating wall in between.

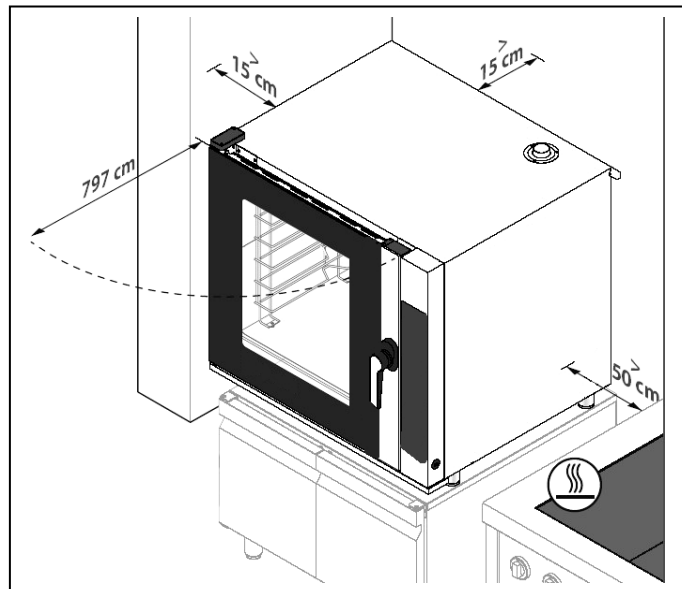

⚠ You must finally make sure that the temperature and relative humidity of the room where the equipment is installed must never exceed the maximum and minimum values indicated in its characteristics (see Enclosure A). Exceeding the maximum temperature or relative humidity in particular may easily and unpredictably cause a breakdown or damage the electrical equipment and create a dangerous situation.

When choosing the place to install the cooking modules T Ànemos take account of the fact that they can be completed by other modules in the series (hood, proofer, etc.).

⚠ For safety reasons, do not place the highest baking pan higher than 160 cm. If this is needed, it is mandatory to apply the adhesive  “burn hazard” supplied with the equipment.

4.3. Moving the module

To unload and transport the module when it is still in its packaging, use a forklift truck or transpalett of a capacity at least that of the weight of the module, sliding the forks into the space provided under the bottom of the packaging.

⚠ In any case, to avoid sudden movements, take into account the position of the centre of gravity.

⊘ To avoid any damage to the module, place protective material between it and the forks.

4.4. Electrical connection

⚠ The equipment is supplied with electrical connection cable with an earth wire. In observance of the safety regulations currently in force **it is compulsory to connect the earth wire (yellow-green) to an equipotential system whose effectiveness must be properly checked in accordance with the regulations in force.**

The figure below shows the position of the equipotential bonding terminal on the oven and its symbol:

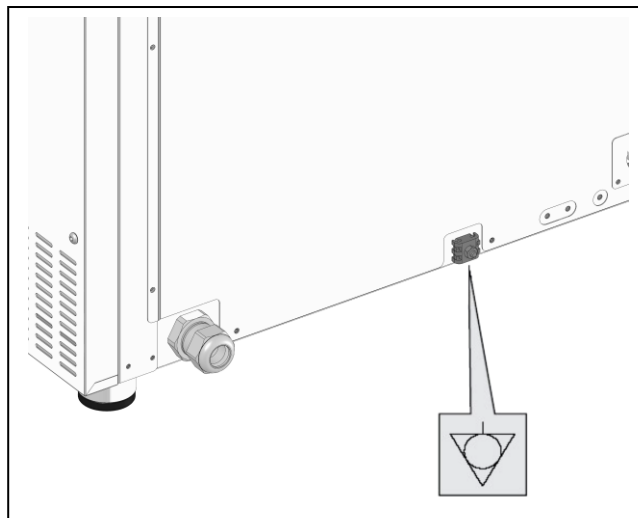

⚠ Before carrying out any connections make sure the mains supply corresponds to that to which the equipment has to be connected (see Enclosure A).

See Enclosure A for the exact cable output position for the equipment supply.

The supply cable must end with a plug to connect to an electrical supply board with a corresponding socket and differential magnetothermal switch.

The plug-socket connection must be such that the earth wire is connected and first and disconnected last and must be of the right size for the nominal current (see Enclosure A). Type CEE17 plugs and sockets are suitable, and any others satisfying the European norm EN 60309.

The thermal safety device must be calibrated for the total nominal current, the magnetic safety device must be calibrated for the maximum instant current (in the case of ovens it is little more than the nominal current, while in the case of machines it is the surge current of the most powerful motor), while the differential device must be set at the 30 mA current (see Enclosure A).

 **The Manufacturer shall not be liable for any damages suffered as a result of failure to observe the above norms.**

4.5. Connection of steam outlet

During cooking, hot fumes and odours are produced which are evacuated from the chimney at the top of the appliance.

The fumes must be carried outside according to the solution provided by the place of installation:

- oven without extractor hood: to be placed under the hood connected to a fume exhaust system with suitable draught.
- oven with extractor hood (400 m³/h): Ø200 mm tube to be connected to a vapour exhaust system with suitable draught;
- oven with extractor hood (600 m³/h): Ø135 mm tube to be connected to a vapour exhaust system with suitable draught..

⊘ Avoid long horizontal sections where condensation could accumulate with possible dripping.

⊘ Do not connect suction units as they would cause too much of a pressure drop that would take heat out of the cooking chamber even with the valves closed.

See Enclosure B for the exact connection position.

4.6. Water connection

NB: The electromechanical version of the T Ànemos oven is not equipped with the washing function and it is not possible to install it later.

4.6.1. Inlet water

The appliance is equipped with a ø 8 mm inlet with filter. A 1.5 m tube with G3/4" connections is also supplied, as required by current regulations, to be mounted during installation.

 For connection, use only the material supplied, do not use or reuse other tubes.

 Before connecting the tube to the appliance, drain the water to eliminate any impurities present in the water pipe.

 Provide a gate valve to shut off the water supply as needed.

NB: The water inlet in the electromechanical version is only used for cooking that requires humidification.

See Enclosure B for the exact connection position.

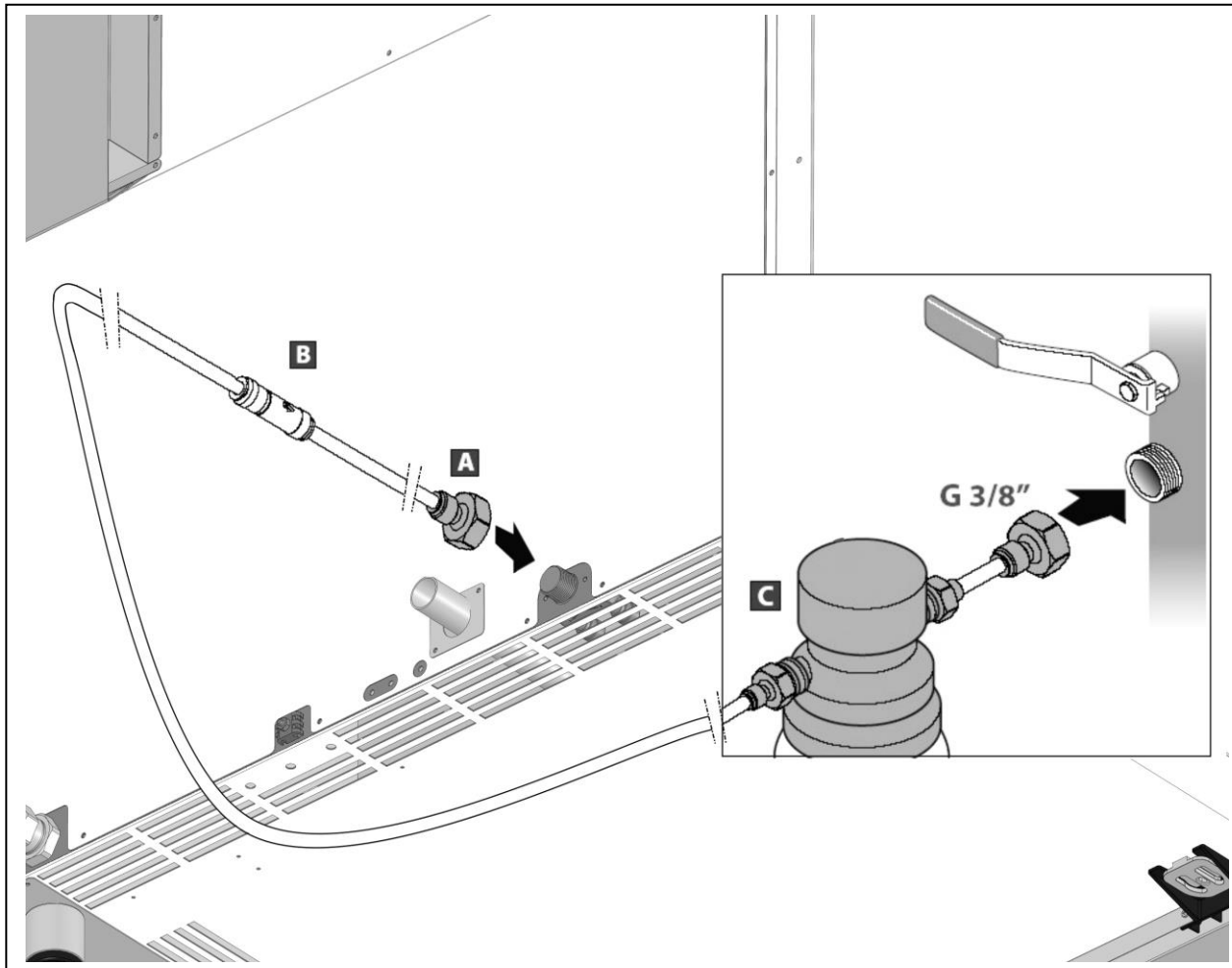

- A: Water inlet \varnothing 8 John Guest;
 B: Non-return valve;
 C: Water filter cartridge (NOT SUPPLIED).

INLET WATER FEATURES.

The inlet water must have the following characteristics:

- maximum temperature of 30°C (86°F);
- maximum hardness of 5°f (French degrees) to avoid limescale build-up inside the cooking chamber;
- be drinkable;
- pressure values between 150 kPa (1.5 bar) and 200 kPa (2 bar);
- the inlet water must be free from chloramines or present levels not exceeding 0.1 ppm (Ng/l). Warning! Any damage caused by excess chloramines is not covered by the warranty.

Pressure below 150 kPa (1.5 bar): the appliance may not function properly.

Pressure above 200 kPa (2 bar): install a pressure reducer calibrated at 200 kPa (2 bar).

Excessively hard water (> 5°F): use demineralisers; Excessive hardness of the water could cause limescale build-up inside the cooking chamber and damage the internal tubes, heating elements, fans and solenoid valves.

4.6.2. Outlet water

Connect the drain to a hose, NOT metallic, able to withstand high temperatures (over 90°C).

The drain must have the following characteristics:

- be of the siphon type (SIPHON NOT SUPPLIED);
- be a maximum of one meter long;
- have a minimum slope of 4%;
- not have bottlenecks;
- have an "air gap" of at least 25 mm;
- have a diameter not less than that of the drain connection.

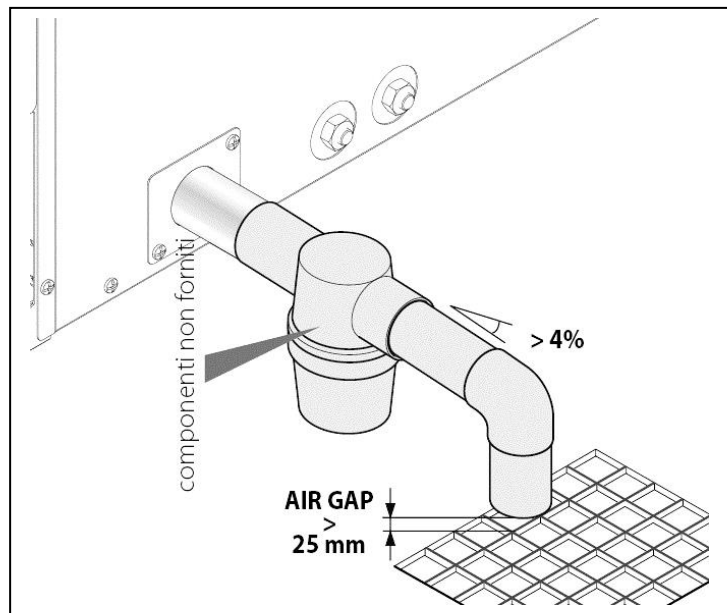

⚠ If you often cook large quantities of fatty foods (e.g. poultry), do not use the siphon and add a fat separator or drain directly into a grate. In both cases, maintain the indicated "air gap".

Filling the siphon.

At the end of installation, pour at least 1 litre of water (0.264 gal.) into the drain in the cooking chamber of the oven to fill the siphon.

"Air gap" means the gap between the drain pipe and the evacuation area (grate or other receiving tube). Compliance with this regulation guarantees that potentially dangerous bacteria CANNOT come back up the drain pipe and contaminate dishes.

See Enclosure B for the exact connection position.

4.7. Checking before starting work

After completing installation of the unit a series of checks must be carried out, listed as follows:

- check that the various disassembled parts have been assembled.
- Check the power cable.
- Check that the control panel is working.
- Check that the apertures for ventilating the room are adequate.
- If present, check that the ventilation hood is working.

5. FUNCTIONING

5.1. Control panel

Fig.5.1. shows all the controls on the control panel:

5.1.1. Temperature control

 Baking chamber temperature display;

 Button SET e ESC;

 Disabled button;

 Button DOWN;

 Button UP;

"out1" Led green display.

5.1.2. Timer control / Start and Stop cooking

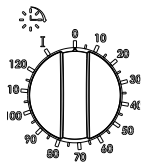

Electromechanical timer.

5.1.3. Humidification control

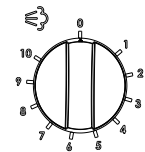

© Humidification regulator + light.

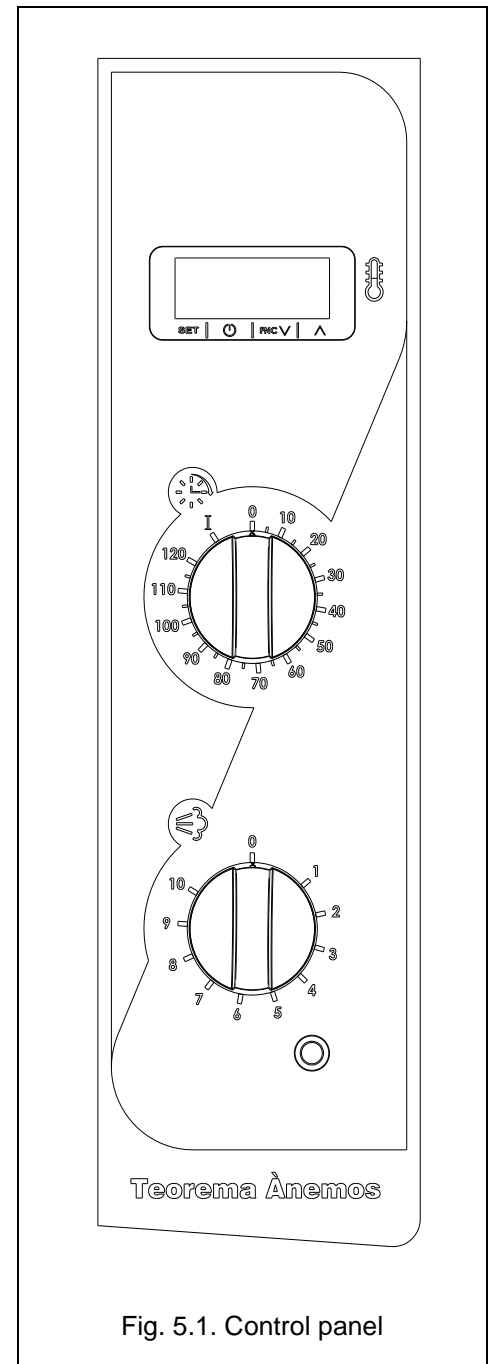

Fig. 5.1. Control panel

5.2. Control description

5.2.1. Chamber temperature display



In normal operating mode this display shows the chamber temperature in °C.

In temperature programming mode this display shows the programmed temperature.

The same display is used for error messages (5.3).

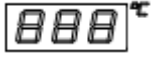

5.2.2. Button

Instantly tap the button once  to enter the temperature programming mode to set the "SP" set point.

The display  shows the wording "SP" and then shows the programmed temperature which can be changed using the  and  buttons.

If no buttons are pressed for more than 15 seconds, the thermostat automatically returns to the normal operation mode.

Once the desired temperature is set, press  to confirm and exit the temperature programming mode.

 **WARNING! do not hold down the  button for more than 5 seconds because the internal parameters of the thermoregulator may change with consequent unpredictable malfunctions.**

See Enclosure A for the range of temperatures that can be selected.

5.2.3. Buttons and .

By pressing and releasing these buttons once, the set temperature increases or is reduced by one unit. Keeping them pressed in the temperature steadily increases or decreases, first slowly then more quickly.

5.2.4. "out1" display led green

The "out1" display led green turns on every time the baking chamber temperature is below the set temperature. It turns off when the cooking chamber temperature reaches the set temperature and goes on again

when the baking chamber temperature goes 1° C below the set temperature. The green led "out1" is blinking when you enter into the program of the oven.

5.2.5. Locking/unlocking the keyboard

The keyboard locks automatically after 30s of no action on the thermoregulator buttons.

If the keyboard is locked you will not be allowed to:

- Modify the working setpoint with the procedure related in paragraph 5.2.2.

This operation provoke the visualization of label "**Loc**" 1 second.

To unlock the keyboard:

- Press  1 seconds: the display will show "**UnL**" 1 second.

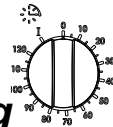

5.2.6. Timer / Start and Stop cooking

When this timer is in position 0, the oven is switched off regardless of the set temperature.

Turning it and selecting the desired cooking time starts the oven operation: the lamp and the heating elements come on and the cooking cycle begins.

At the end of the cooking cycle the buzzer sounds for 25 sec.

Turning it to position "I" starts the operation of the oven for an infinite amount of time.

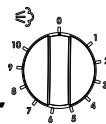

5.2.7. Humidification regulator

This regulator allows you to inject water to create humidity inside the cooking chamber. The regulator scale goes from 0 to 10 which corresponds to the quantity of water introduced into the chamber.

Humidification can be activated at any time during the cooking cycle.

5.2.8. Humidification light

The light comes on when humidification is activated by means of the regulator.

5.3. Fault signal

5.3.1. Disconnected thermocouple

When the thermocouple is disconnected or interrupted, the display shows "PR1".

The same fault code appears even if the chamber temperature is higher than the maximum settable temperature.

6. USE

6.1. Preparation for use

 If the equipment has just been installed or if it has been idle for several days, before using it to work with food products it must be completely cleaned in accordance with the procedure in chapter 7, to eliminate manufacturing residues, accumulations of dust or other substances that could contaminate the food products.

6.2. Switching on the control panel.

By turning on the main switch on the power supply panel, the thermoregulator is activated and the desired parameters can be set, while the cooking chamber is still off.

NB: as soon as the oven is powered up, the buzzer will sound for about 25 seconds, to interrupt it, use the Timer/Start-Stop knob and turn on the cooking cycle see 5.2.7.

6.3. Settings

Set the required temperature using the buttons

 (see 5.2.2 and 5.2.4).

6.4. Start cooking

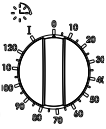
At this point, turn the timer/start and stop cooking knob  setting the desired time: in a short time the chamber temperature will begin to rise. If you have set the maximum temperature, the oven will reach this in 10-15 minutes when the oven is empty.

During cooking, you can:

- change the parameters relating to the cooking timer and temperature;
- switch humidification on and off.

6.5. Loading the oven

 **Warning, when the chamber is up to its temperature the glass and metal parts of the door and some surrounding parts reach temperatures that are dangerous if touched. Caution!**

6.6. Use of humidification

We recommend the use of humidification at a chamber temperature not lower than 150 °C.

6.7. General good cooking indications

In general it is not possible to indicate the right temperature for cooking food products because of the enormous range of their characteristics.

We nevertheless advise at least the carrying out of some trials (especially if you have never worked with this particular oven before) bearing in mind the following points:

1. It is normal for there to be a drop in temperature of the product even of 20-30°C immediately after being loaded into the oven. This is not a limitation of the oven but rather a useful indication that at the start of cooking the raw product is losing a great amount of heat from evaporation of water present. To overcome this drop in temperature, we recommend setting a higher temperature so that the desired temperature is reached when the product is placed in the oven. In any case, if the oven is used within its maximum capacity, towards the end of cooking the temperature will start to rise again.
2. The oven has a production capacity expressed in Kg of product per hour. If this maximum production is exceeded, the temperature in the cooking chamber will decrease as much as 20-30°C. If this is the case it will be necessary to remove the excess quantity of product and wait until the temperature has been reestablished before the next baking session.
3. avoid salting food in the cooking chamber. If this cannot be avoided, clean the appliance as soon as possible.
4. arrange the food evenly on the baking pans, avoiding overlapping or overloading the food (for maximum capacity, see attachment A). Distribute the baking pans evenly throughout the entire height of the cooking chamber, respecting the maximum number indicated for each appliance. Always respect the load indications of the appliance in your possession.
5. if cooking particularly fatty foods with grilles (for example roasts or poultry), place a pan with high edges on the bottom of the cooking chamber to collect the grease that drips from the food.
6. for best results, open the door as little as possible during cooking.
7. use the appliance with an ambient temperature between +5°C and +45°C (+ 41°F and +113°F).

NB: even cooking is guaranteed by reversing of the direction of rotation of the fans which takes place at regular intervals (1.40 min. in one direction,

20 sec pause and 1.40 min. in the other). This function allows even diffusion of hot air in the cooking chamber.

6.8. Switching off

At the end of each working day, set all the knobs to position 0.

 When there are long periods of idleness (for example on closing for vacations) it is advisable to switch off the mains supply switch on electrical panel and close the water supply taps.

6.9. Clean

 At the end of each working day (if not more often) it is necessary to carefully clean the hob and all parts of the oven that came into contact with products, to ensure that such foodstuffs do not degrade and pollute the products that will be subsequently cooked.

For proper cleaning see chapter 7.

7. CLEANING

⚠ Cleaning needs to be carried out with the equipment switched off and at ambient temperature, after having first switched off the electrical supply with the switch on the electrical panel.

7.1. Cleaning of the oven cooking chambers

Clean the cooking chamber daily to maintain high levels of hygiene and to preserve the brilliance of the steel and the performance of the appliance over time.

Cleaning must always be carried out with a cold chamber: use a soft cloth soaked in hot soapy water and finish with rinsing and drying. The internal baking pan holder guides are removable for easy cleaning

Carefully remove any fat or grease deposits with a spatula.

⊘ Do not use abrasive or corrosive detergents as this will remove the shine from stainless steel and quickly remove the protective layer, causing it to oxidise quickly.

⚠ Do not use jets of water as they may enter the electrical panel with a resulting danger of electrocution or sudden start up.

7.2. Cleaning outside surfaces

⚠ The tempered glass parts are particularly sensitive to sudden variations in temperature that can cause them to crack into tiny fragments. **Do not handle glass parts and do not bring them into contact with water until they have cooled down to room temperature.**

To clean outside surfaces made with stainless steel as well as control panels, use a soft damp sponge, if necessary with a mild, non-abrasive detergent.

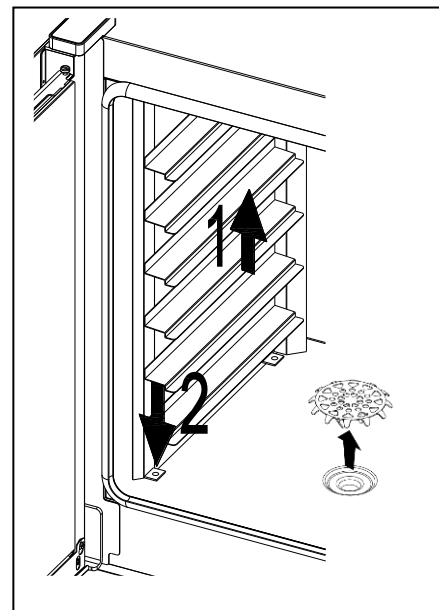

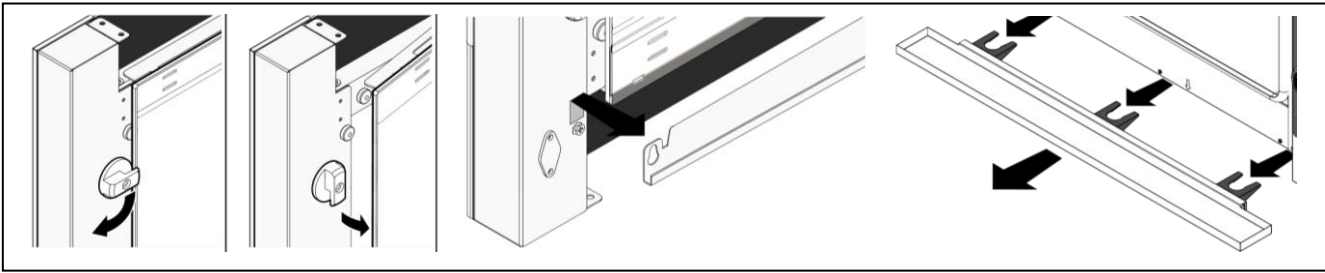

⚠ It is not recommended to use abrasive tools (abrasive sponges or similar) because over time they take the shine off the stainless steel parts and high impact glass.

⚠ Do not use jets of water as they may enter the electrical panel causing damage to it with a resulting danger of electrocution or sudden start up.

8. MAINTENANCE

⚠ WARNING: These maintenance instructions are for the exclusive use of qualified personnel for the installing and maintaining electrical equipment. Maintenance by other non qualified staff may cause damage to the equipment, persons, animals or things.

⚠ To carry out repairs and checks it is necessary, in most cases, to remove fixed guards. This will make live wires accessible. **Before carrying out any maintenance operations check that the electrical supply plug for the equipment is unplugged from the panel. Store the plug in a place visible to the maintenance technician so that he or she can easily make sure that it is disconnected during all operations with fixed protections removed.**

8.1. Ordinary maintenance operations

8.1.1. Replacing light

Unplug the electrical supply at the panel.

⚠ The compartment where the light is positioned is in an area of the oven that is not insulated. This means that if this compartment is closed it reaches high temperatures when the oven is working.

The light should therefore only be replaced when the oven is cold, or using protective gloves.

Open the oven door (1).

Release the right baking pan holder guide by first moving upwards (2) then towards the inside of the chamber (3).

Unscrew and remove the cover and the lamp holder glass (4).

Replace the bulb with one of the same characteristics (5).

Reassemble everything in the opposite sequence to that described above.

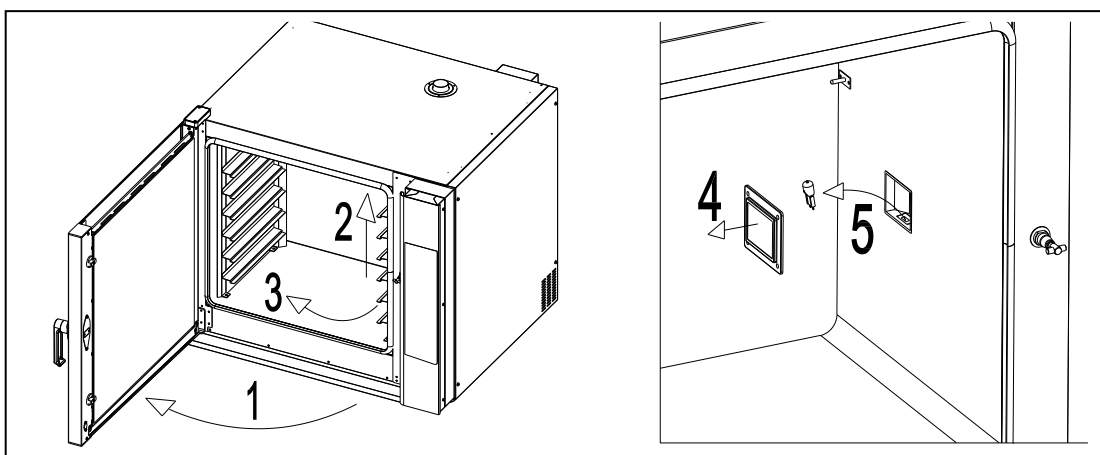

8.1.2. Door adjustment

If it is difficult to close the door, it is possible to adjust the door track by rotating it with pliers and a spanner until a perfectly horizontal position is obtained.

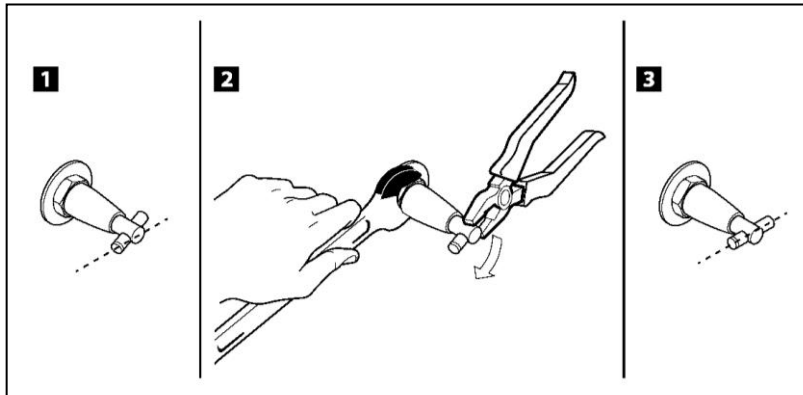

8.2. Fault signals

The electronic check can recognise some malfunctions, for details see 5.3.

8.3. Adapting to different supply tensions

⚠ Warning! To adapt the equipment to work at voltages other than that indicated in the label, refer to the image below, which shows how to position the jumpers on the terminal block, based on the type of voltage available.

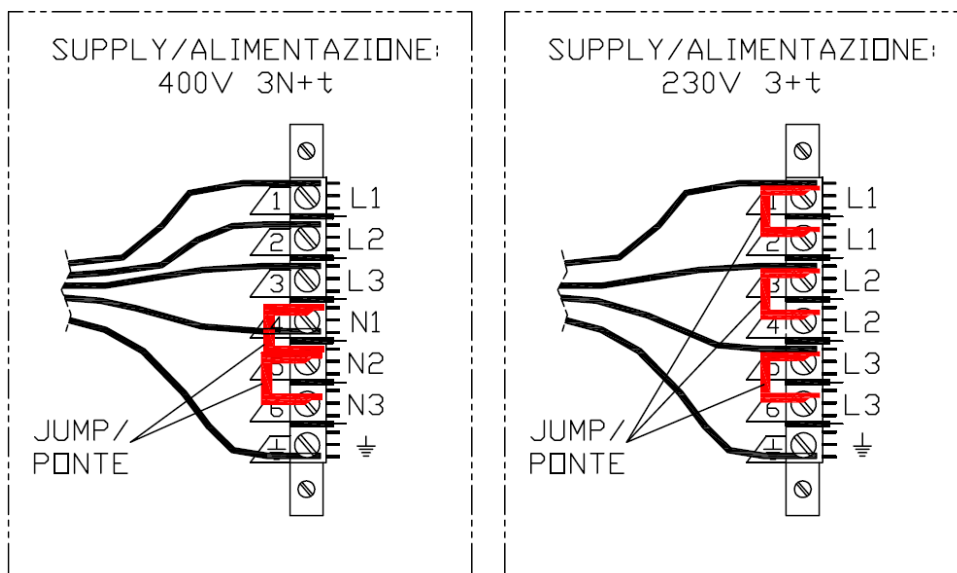

To make the connections, use only the jumpers supplied with the oven.

8.3.1. Application of the new label.

Remove the old label from the plate on the back of the equipment, clean the area with a cloth dampened with petrol and apply the new label.

9. DECOMMISSIONING AND DEMOLITION

Before proceeding with the decommissioning disconnect the electrical supplies to the equipment and any other connections there may be and then move the modules using suitable means such as: forklift trucks, hoists, and so on. The machines are made up of the following materials: stainless steel, coated steel, glass, ceramic material, rock wool and electrical parts. For the purposes of demolition therefore the materials have to be separated in observance with the norms in force in the place where the machine is being dismantled.



Separate collection. This product must not be disposed of with normal household waste. Local RAEE regulations may provide for separate collection of this kind of product.