



## **MOD: TIBERIO-9E**

**Production code : AVM0E07B + FIAN1063**

**04/2026**









## **AVGVSTO E 6 - 9/MC**

Manual for installation, use and maintenance

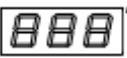

# INDEX

<b>1.INTRODUCTION.....</b>	<b>5</b>
<b>2.HOW TO USE THIS MANUAL.....</b>	<b>6</b>
<b>3.SPECIFICATIONS .....</b>	<b>8</b>
3.1.Product identification.....	8
3.2.Conformity to directives .....	8
3.3.Envisaged use.....	8
3.4.Technical specifications .....	8
<b>4.INSTALLATION.....</b>	<b>9</b>
4.1.Checking on delivery.....	9
4.2.Choosing a place for installation .....	10
4.3.Moving the unit .....	11
4.3.1.Parts removable for handling.....	12
4.4.Mounting optional components .....	16
4.5.Electrical connection.....	19
4.6.Emissions from cooking appliance .....	21
4.7.Positioning the slabs of refractory material .....	22
4.8.Checking before starting work.....	27
<b>5.WORKING .....</b>	<b>28</b>
5.1.Control panel.....	28
5.1.1.Temperature control .....	28
5.1.2.General.....	28
5.1.3.Power control .....	28
5.2.Control description.....	29
5.2.1.  <i>Main ON/OFF switch</i> .....	29
5.2.2.  <i>Baking chamber light switch</i> .....	29
5.2.3.  <i>“Air Trap System” switch</i> .....	29
5.2.4. <i>Temperature control</i>  <i>Baking chamber temperature display</i> .	29
5.2.5.  <i>Button</i> .....	30
5.2.6. <i>Buttons</i>  <i>and</i>  .....	30
5.2.7. <i>“out1” display led green</i> .....	30

5.2.8.Locking/unlocking the keyboard .....	30
5.2.9.Power regulators .....	31
5.2.10.Oven roof and bedplate .....	31
5.3.Error display.....	32
5.3.1.Disconnected thermocouple .....	32
<b>6.USE .....</b>	<b>33</b>
6.1.Preparation for use.....	33
6.2.Ignition of the control panel .....	33
6.3.Settings.....	33
6.4.Baking start .....	33
6.5.Loading the oven .....	33
6.6.General indications for good cooking .....	34
6.7.Turning off.....	35
<b>7.CLEANING .....</b>	<b>36</b>
7.1.Cleaning the exposed parts.....	36
7.2.Cleaning the parts made from refractory material .....	36
7.3.Cleaning the oven's cooking chamber .....	37
7.4.Cleaning external surfaces.....	37
<b>8.MAINTENANCE.....</b>	<b>38</b>
8.1.Ordinary maintenance work .....	38
8.1.1.Light replacement .....	38
8.1.2.Tightness check of mains power connections.....	39
8.1.3.Control Panel cleaning .....	39
8.2.Safety thermostat .....	39
8.3.Error displays.....	40
8.4.Electrical diagram.....	41
8.5.Adjustment for different feed voltages.....	41
<b>9.DECOMMISSIONING AND DEMOLITION.....</b>	<b>42</b>

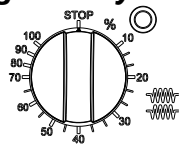

**TECHNICAL ENCLOSURES**

- |                             |                    |
|-----------------------------|--------------------|
| A. Technical Specifications | C. Wiring diagrams |
| B. Connections              | D. Exploded views  |

# 1. INTRODUCTION

The electrically fed "DOME OVEN" have been designed mainly for the baking of pizzas and similar products in a traditional way.

Of a high mechanical and electrical quality, the "DOME OVEN" are built with a single frame, in a version with baking surfaces housing 6 or 9 pizzas having a 30 cm diameter.

As part of a modular series, these ovens can be combined with other elements of the same range (hood, proofing chamber, base and base modules), thus meeting each Customer's specific requests.

In particular the ELETTROMECHANICAL version, which we are referring to in this manual, has been conceived to give our Customers a reliable, user-friendly oven with base functions for a pizzeria oven.

The manufacturer wish to thank you for the preference you us by choosing this product. We can assure you that you made a good choice, since for decades our company has been committed to the manufacture of quality products without compromises in the selection of the best materials.

For a better use of your new oven, we are asking you to follow the instructions given in this manual.

## 2. HOW TO USE THIS MANUAL

 The paragraphs with this symbol contain essential safety information. They must all be read both by the installers and by the final user and any of his staff who may use the equipment. The manufacturer shall not be held liable for any damage which may occur as a result of failure to observe the norms indicated in these paragraphs.

 The paragraphs with this symbol contain important information which can be used to avoid damage being caused to the equipment. It is the user's own interest also to read these paragraphs carefully.

 This symbol, applied to various points on the oven, serves to warn the user of the presence of a non-insulated "high voltage hazard" inside the oven's casing, there being enough power to constitute a fire risk or to electrocute a person.

 This manual should be kept near to the equipment itself so it can be quickly and easily consulted. The manual must travel with the equipment if it is moved to another owner as the latter may not be considered complete or safe without it.

Please take note of the code and revision numbers which are behind the back cover. If this copy should get mislaid or destroyed you can order another one by referring to the codes.

 This manual is divided up into a number of chapters. All of these should be read by the installers, maintenance staff and the final user, both in relation to its **safe use** and in order to obtain the best result from this product.

Despite this we also give below some useful indications on how to look things up quickly in the various chapters.

**Chapter 3** describes the field of use of the equipment and provides the characteristics and figures which may be needed when choosing, installing and using it. It should be used as a reference to check the use which is intended to be made of the equipment corresponds to that for which it was designed, and whenever it is necessary to know an exact size value relating to the equipment.

**Chapter 4** provides all the information necessary for the installation of the equipment. The manual is primarily written for specialised staff but may be read in advance also by the final user to prepare and set up the space and plant necessary for the proper working of the equipment.

**Chapter 5** is for reference whenever the user wishes to clarify specific aspects of the equipment operation. **It is not advisable to use these chapters as a way to learn how to use the equipment.**

**Chapter 6 is useful for the user who has to learn to use the oven from scratch.** It guides the user through the essential operations for switching on, use and switching off of the equipment in safety. To exploit all the possibilities of the equipment the user should refer to chapter 5.

**Chapter 7** provides all the information required for the cleaning of the equipment i.e. all those operations which have to be carried out by the user in order to ensure that the equipment continues to function safely (especially from the point of view of hygiene) and generally obtains the best results at all times.

**Chapter 8** provides the information necessary for proper periodic and extraordinary maintenance e.g. repairing or replacing of the equipment.

This chapter also has an exploded view of the equipment and list of spare parts to make ordering and replacing any damaged parts easier.

 These maintenance operations must be carried out by specialised staff.

**Chapter 9** provides the information necessary for the decommissioning and demolition.

## 3. SPECIFICATIONS

### 3.1. Product identification

This manual refers to single chamber "DOME OVEN" 6 - 9, version with electromechanical controls.

### 3.2. Conformity to directives

The above mentioned baking modules carry the compulsory marking  which guarantees their conformity to the following European directives:

2014/35/CE Low Tension Directive

2014/30/CE Electromagnetic Compatibility Directive

2011/65/CE RoHS 2 Directive

1935/2004/CE Regulation for Equipment intended to come into Contact with Foodstuffs.

### 3.3. Envisaged use

The "DOME OVEN" have been designed to bake pizzas and similar products and non fine pastry onto pans or directly on refractory surfaces.

 Such modules are meant for a professional use only by qualified personnel in the restaurant industry (restaurants, pizzerias, pastry shops, etc.) **and are exclusively intended to be used by qualified staff.**

The operations envisaged in normal usage are the loading and unloading of the products from the bedplate of the baking chamber, switching on, regulation, switching off and cleaning of the equipment.

### 3.4. Technical specifications

For technical specifications refer to the following technical annexes at the end of this manual:

- A. Technical Specifications
- B. Connections
- C. Wiring diagrams
- D. Exploded views

## 4. INSTALLATION

 **ATTENTION:** these installation instructions are for the exclusive use of personnel qualified for the installation and maintenance of electrical and gas equipment conceived for professional use in the foodservice industry and community catering operations. An installation carried out by unqualified persons could cause damage to the oven, to people, animals or property.

 **ATTENTION:** Proceed with the installation according to those norms in force in the country where it is being carried out.

In addition, where it is necessary to carry out modifications or adaptations to the electrical or gas systems of the building in which the oven will be installed, whoever carries out such modifications must certify that the work has been undertaken according to current “best practices”.

### 4.1. Checking on delivery

Unless otherwise agreed, the products are carefully packaged in a robust structure in wood and with a sheet of nylon bubble wrap giving protection against knocks and humidity during transport. These are consigned to the freight operator in the best of condition.

We recommend, however, that you to check the packaging on arrival for any signs of damage. If damage has occurred, have it noted on the receipt which must be signed by the driver.

Once the equipment has been unpacked, check that it has not suffered damage. Also check that all the disassembled parts are present.

In the event of damage to the equipment and/or missing parts, bear in mind that the freight operator can only accept claims within 15 days of delivery and that the manufacturer cannot be held responsible for damage incurred to its products during their delivery. We are however, available to assist you in presenting your claim.

 **In the event of damage do not try to use the equipment and consult with professionally qualified personnel.**

## 4.2. Choosing a place for installation

An effective, safe and long lasting functioning of the appliance also depends on the position in which it is installed. For this reason, it is advisable to carefully consider where to install the equipment before it is delivered

Install the appliance in a dry and easily accessible place both to facilitate its use and to carry out cleaning and maintenance. The area around the equipment must be kept clear.

 **The appliance must be installed at least 20cm from the walls of the room or from other equipment.**

Whilst in operation, cooking equipment produces vapor and cooking smells that compromise the integrity of a healthy working environment.

In the case of electric ovens, even if it is not obligatory, the installation of an extraction fan and hood is recommended to improve conditions in the working environment and to avoid damage to the ceiling of the area where it is housed caused by hot, oily fumes.

 A check must be made to ensure that the temperature and relative humidity never exceed the maximum and minimum values indicated in the specifications (see Enclosure A) even when the oven itself or other ovens in the room are functioning.

Exceeding these values especially the temperature or the maximum relative humidity can easily and unexpectedly damage electrical equipment creating hazardous situations.

 **The Manufacturer cannot answer for damage caused by ignoring these abovementioned norms as well as the information in this manual.**

### 4.3. Moving the unit

To offload and transport the unit, use a pallet truck or a transpallet lifter with a load capacity at least equal to that of the unit, insert the forks into the space provided in the lower part of the packing.

In order to transport the unit unpacked, ropes or straps (suitable for lifting heavy loads) must be inserted through the ringbolts on the top of the oven. Then lift the module with a forklift.

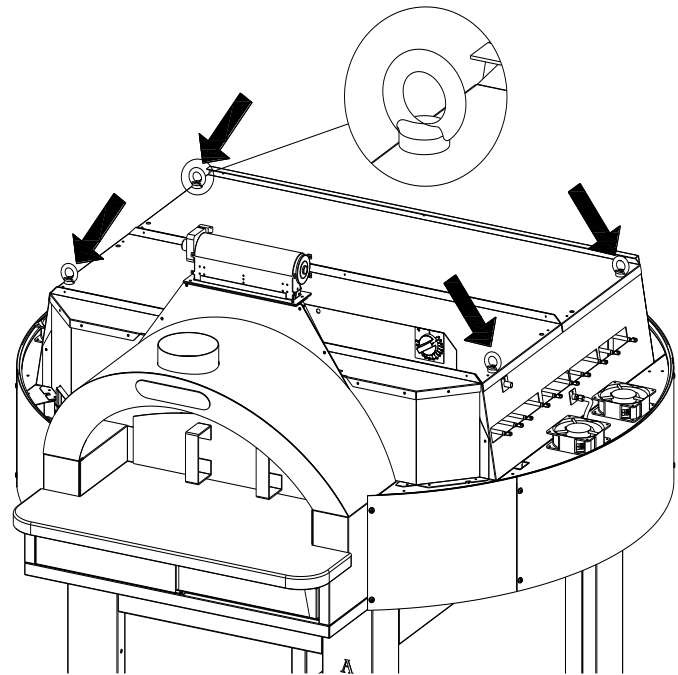

Figure 4.1.

#### IMPORTANT!

When handling the unit, the refractory stones must never be inside the cooking chamber.

⊘ To avoid damage, place protective material between the forks and the unit.

⚠ In all situations, to avoid unpredictable movement, be aware of the equipment's centre of mass (Fig.4.2 e Tab.4.1).

⚠ Take care that children do not play with the packaging materials (e.g., plastic sheeting and Styrofoam): suffocation danger!

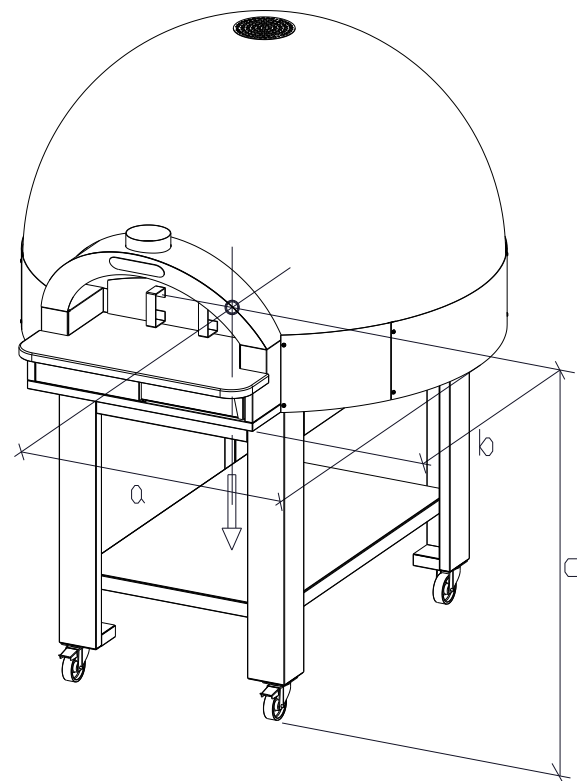

Figure 4.2. Centre of gravity

	a [mm]	b [mm]	c [mm]
6 E	810	790	1200
9 E	955	960	1100

Table 4.1. Centre of gravity

**4.3.1. Parts removable for handling**

For unpacked module handling, see the list and follow the instructions below to remove the removable parts:

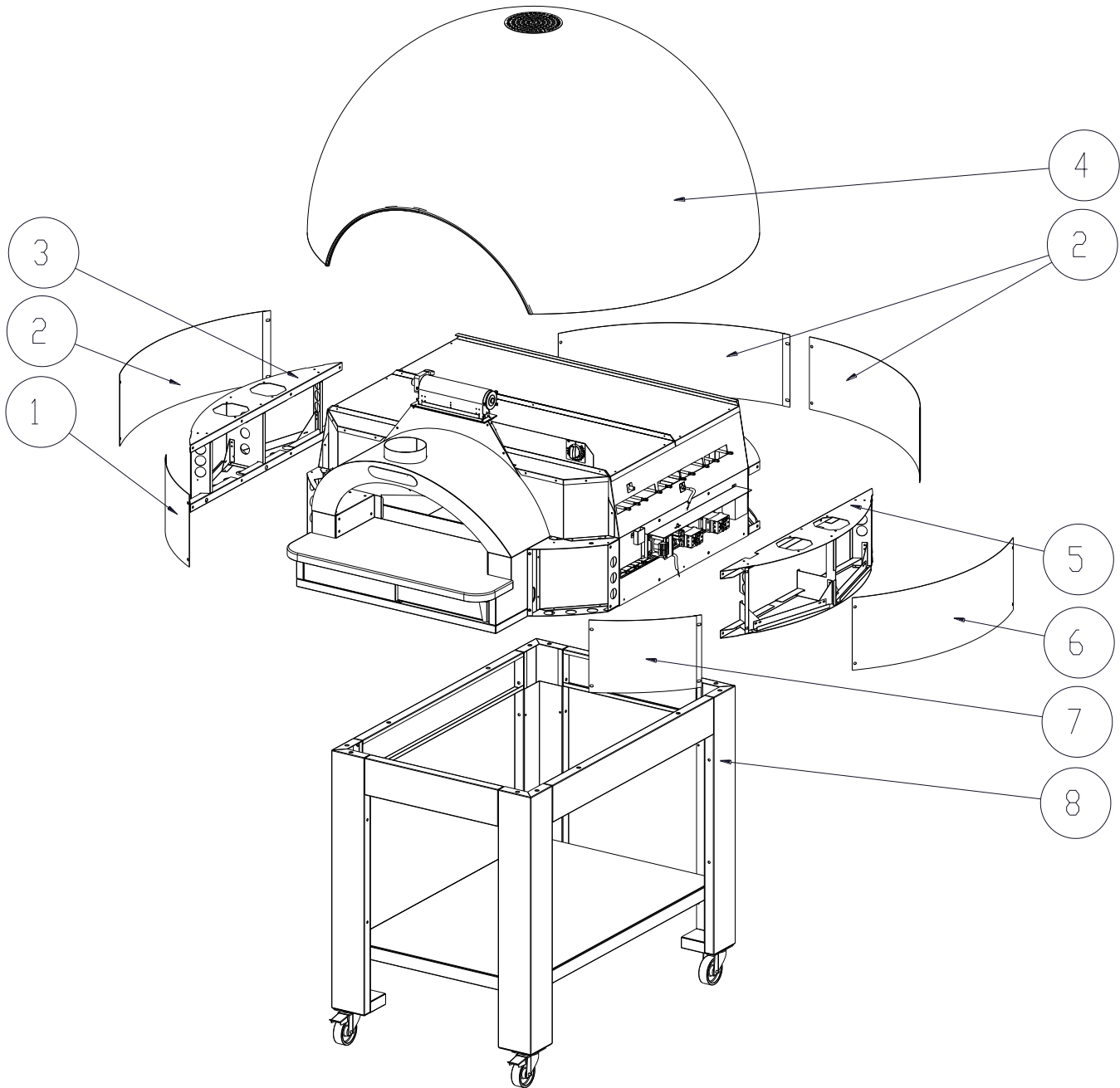

- 1- Front left half-round cover
- 2- Rear left side half-round cover
- 3- Centre left half-round part
- 4- Dome
- 5- Centre right half-round part
- 6- Right side half-round cover
- 7- Front right half-round cover
- 8- Base

**Removing the removable parts:**

- 1- Using a screwdriver, gently lift the dome from the side edge and remove it with an upward motion (Fig. 1).

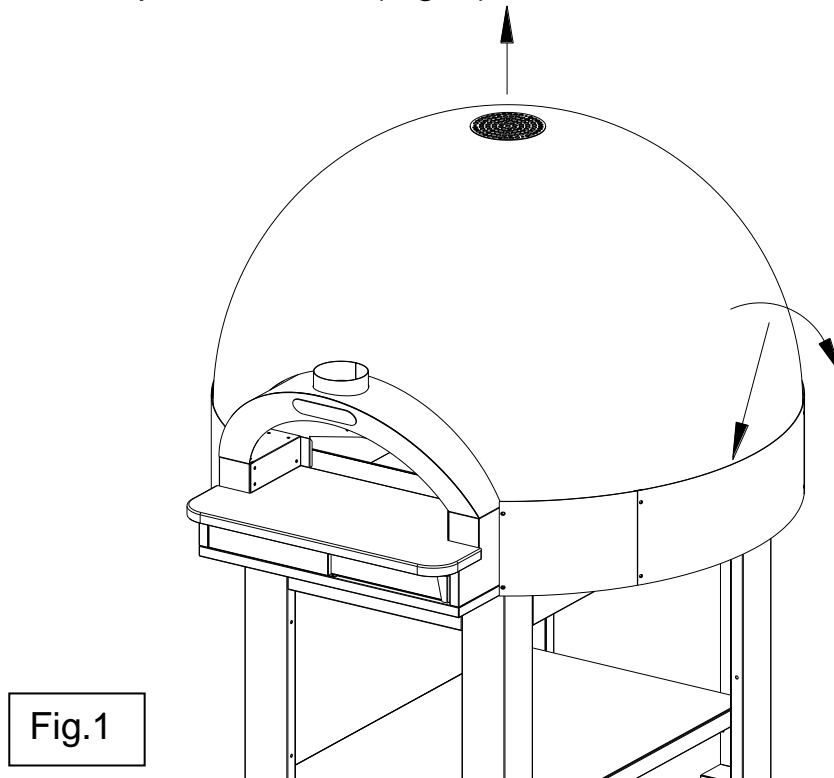

Fig.1

- 2- Separate the module from the base by unscrewing the fixing screws at the bottom (Fig. 2).

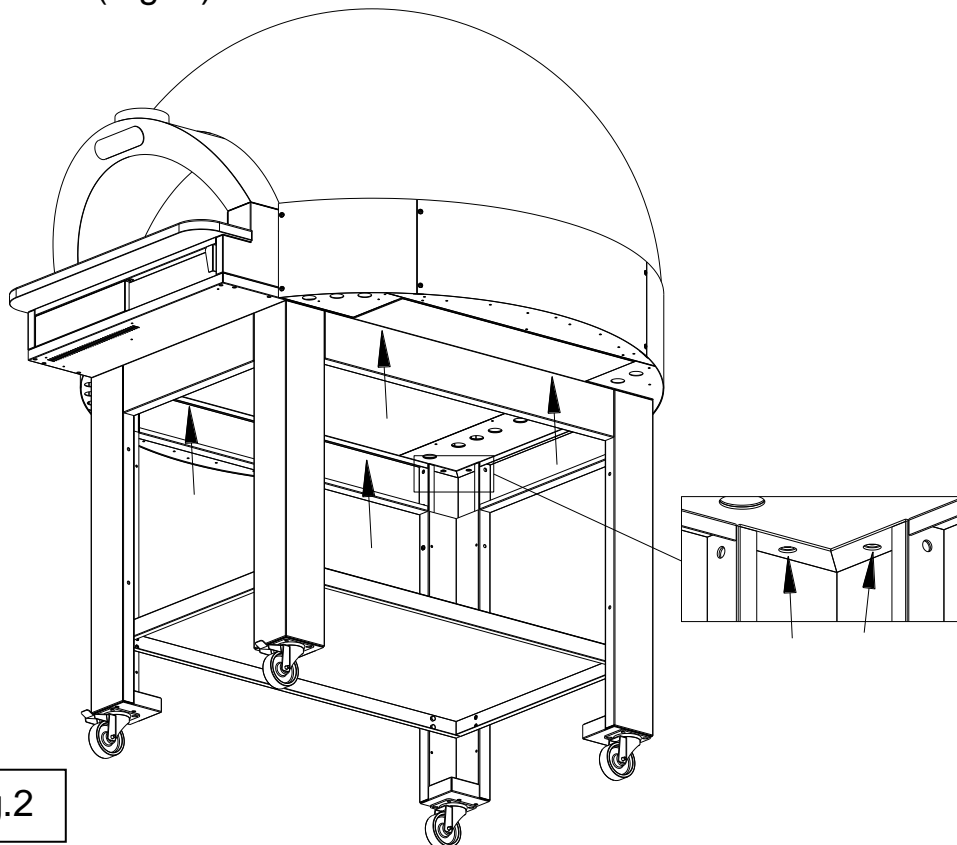

Fig.2

- 3- Remove the side and rear half-round covers following the sequence 1-2-3-4-5-6 (Fig. 3).
- 4- Remove the left and right side half-round parts following the sequence 7-8 (Fig. 3).

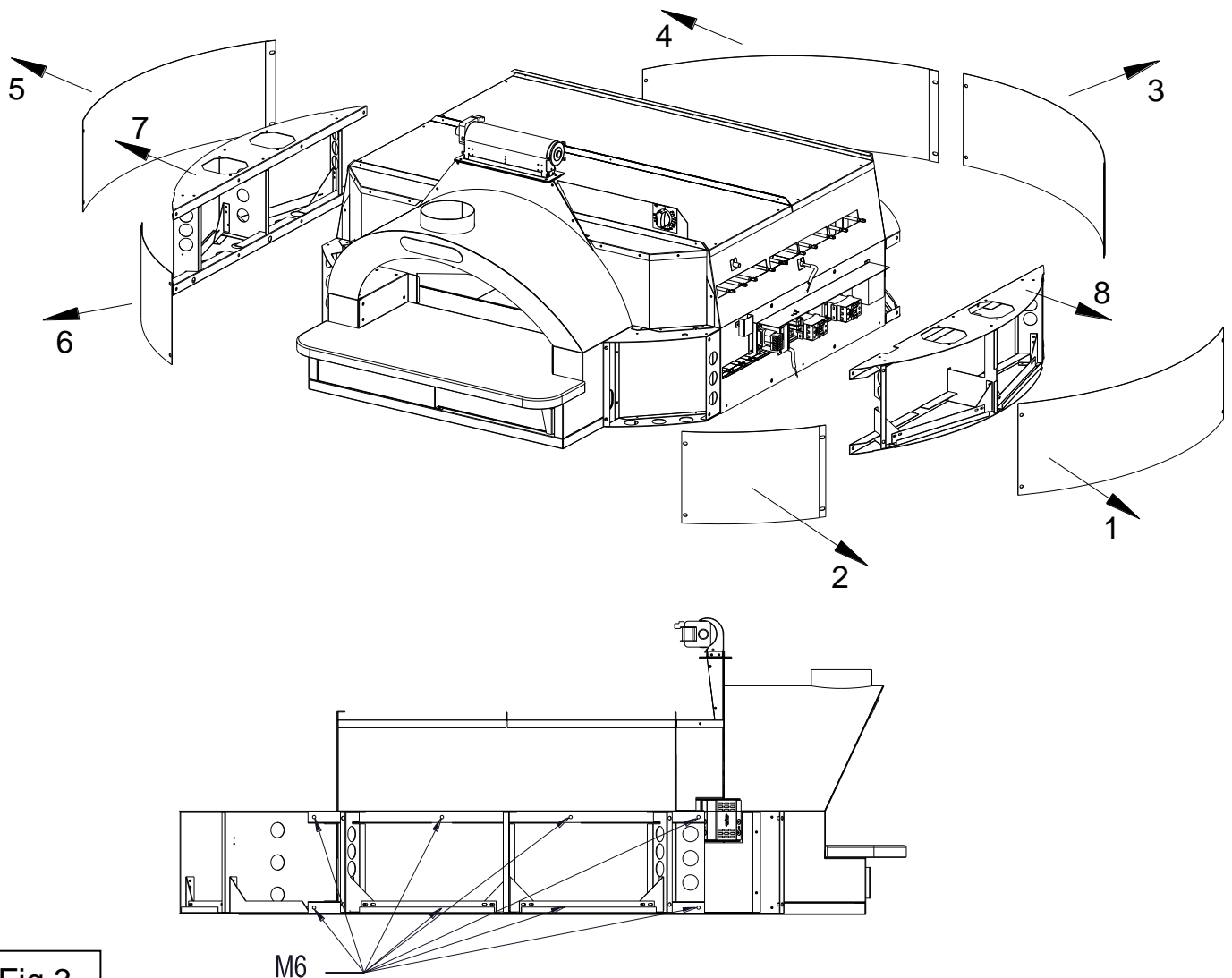

Fig.3

- 5- Rotate the oven 90° counterclockwise and rest it on its left side; in this way, the module can get through a door with minimum encumbrance (800x2100 mm) (Fig. 4).

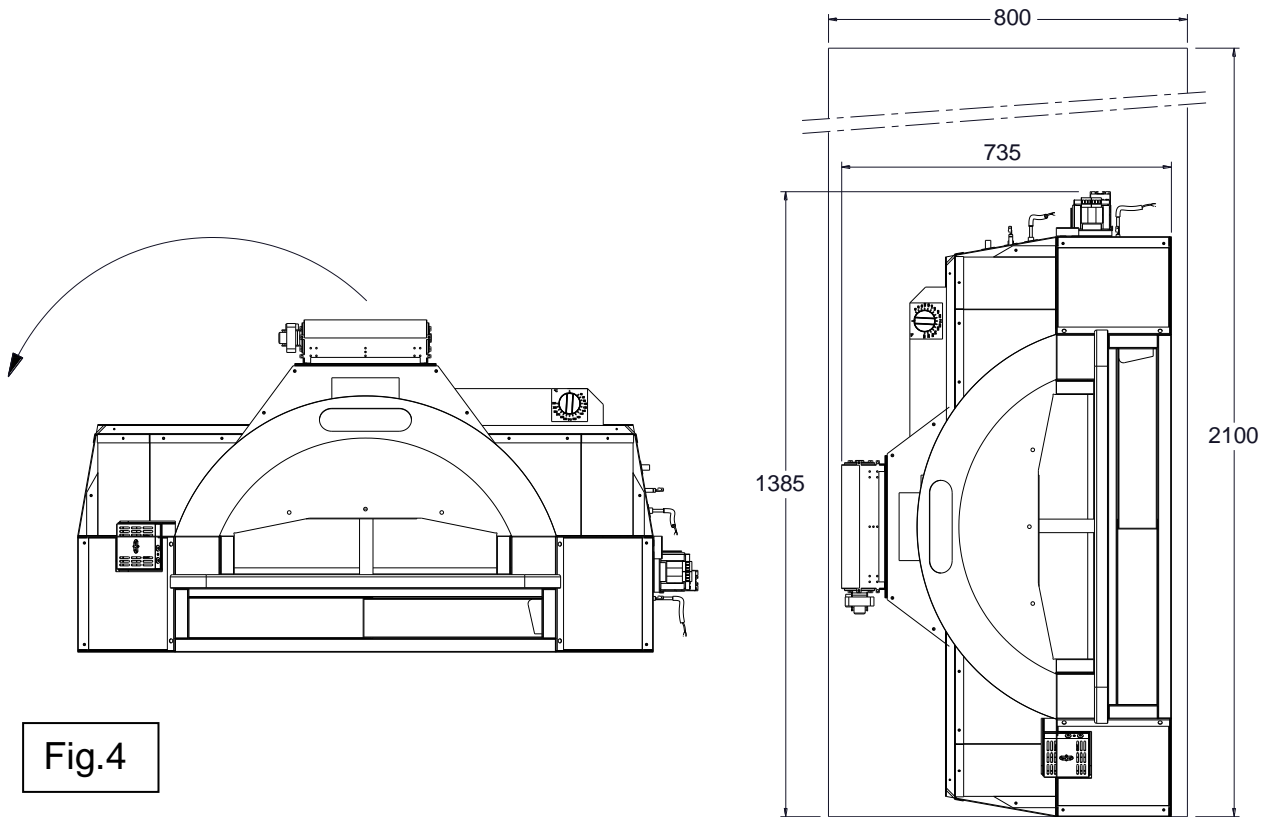
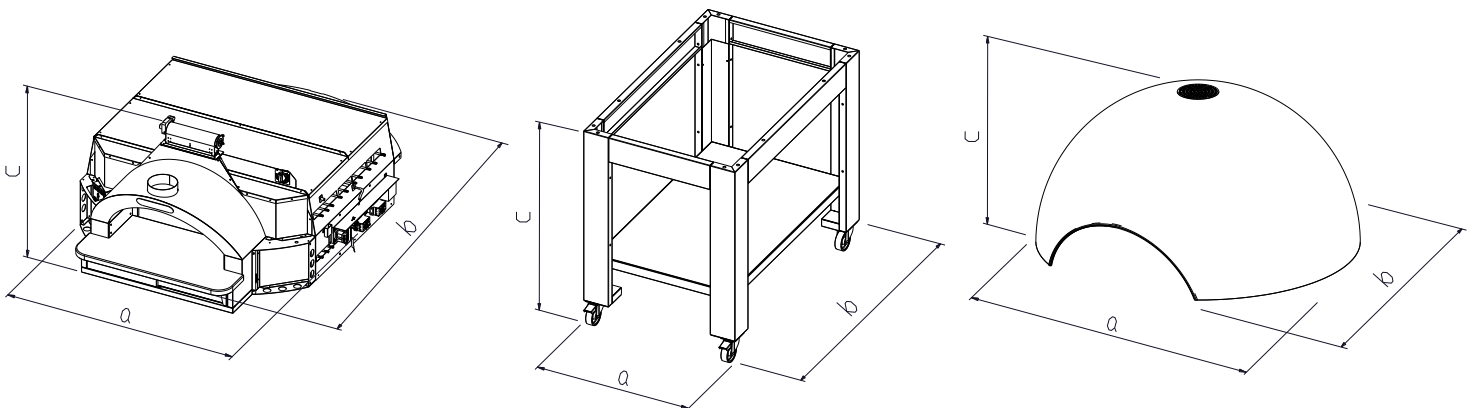

Fig.4

**NB To assemble the removable parts, proceed in the sequence opposite to that described above.**

**Maximum overall dimensions of the individual dismantled parts:  
module, base and dome.**



	a [mm]	b [mm]	c [mm]
<b>6 E MODULE</b>	1283	1796	735
<b>9 E MODULE</b>	1283	2116	735
<b>6 E BASE</b>	850	1323	1108.5
<b>9 E BASE</b>	1130	1500	1028.5
<b>6 E DOME</b>	1610	1544	794
<b>9 E DOME</b>	1900	1828	895

#### 4.4. Mounting optional components

Below are the assembly instructions for the optional components that can be added after purchasing the oven:

##### -Shovel holder kit

- 1- Insert the upper and lower brackets (A) into the frame (B).
- 2- Fix the brackets (A) to the base leg using the screws that are already in there (Fig. 1).

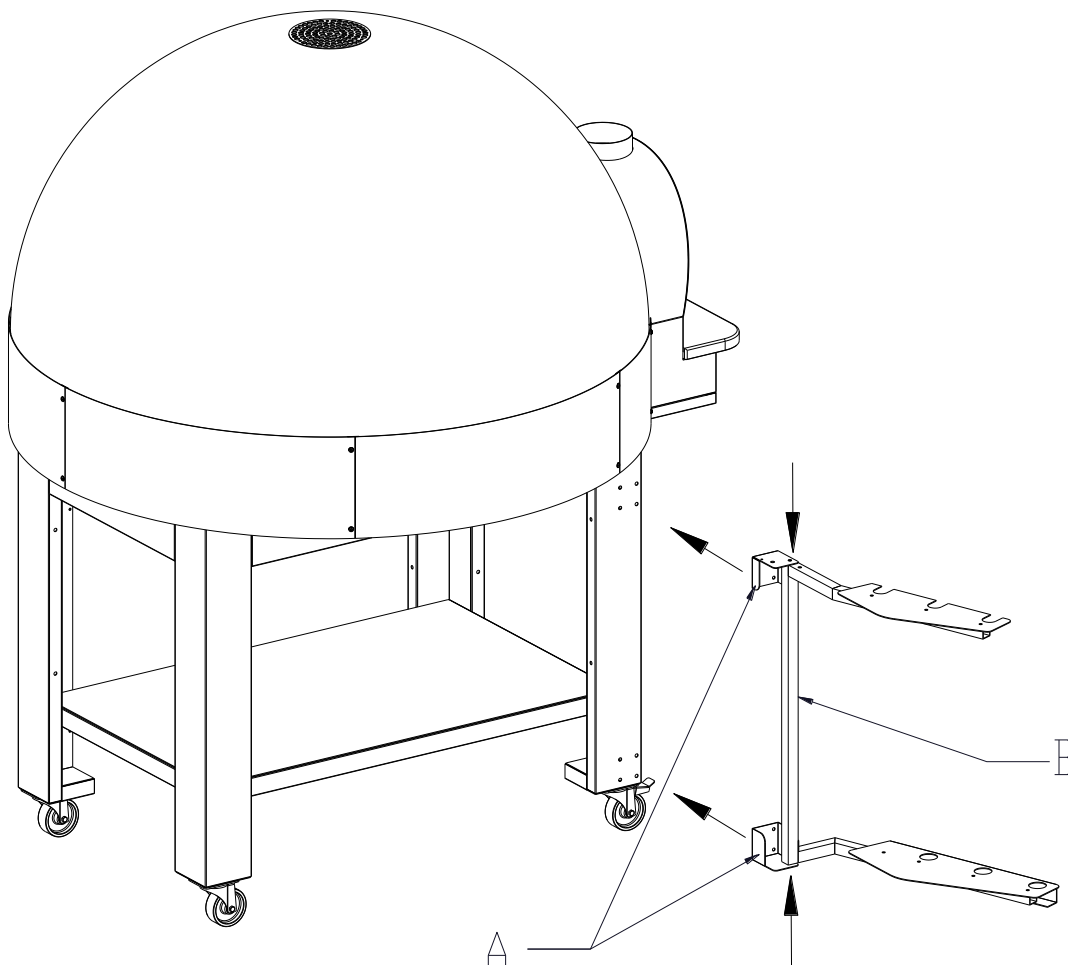

Fig.1

**- Base closing kit with doors**

- 1- Loosen the screws on the legs.
- 2- Set the left side panel in position and fasten it to the legs using the shaped screw holes and screws (Fig. 2), then fix the screws. Repeat the operation with the right side and rear panels.

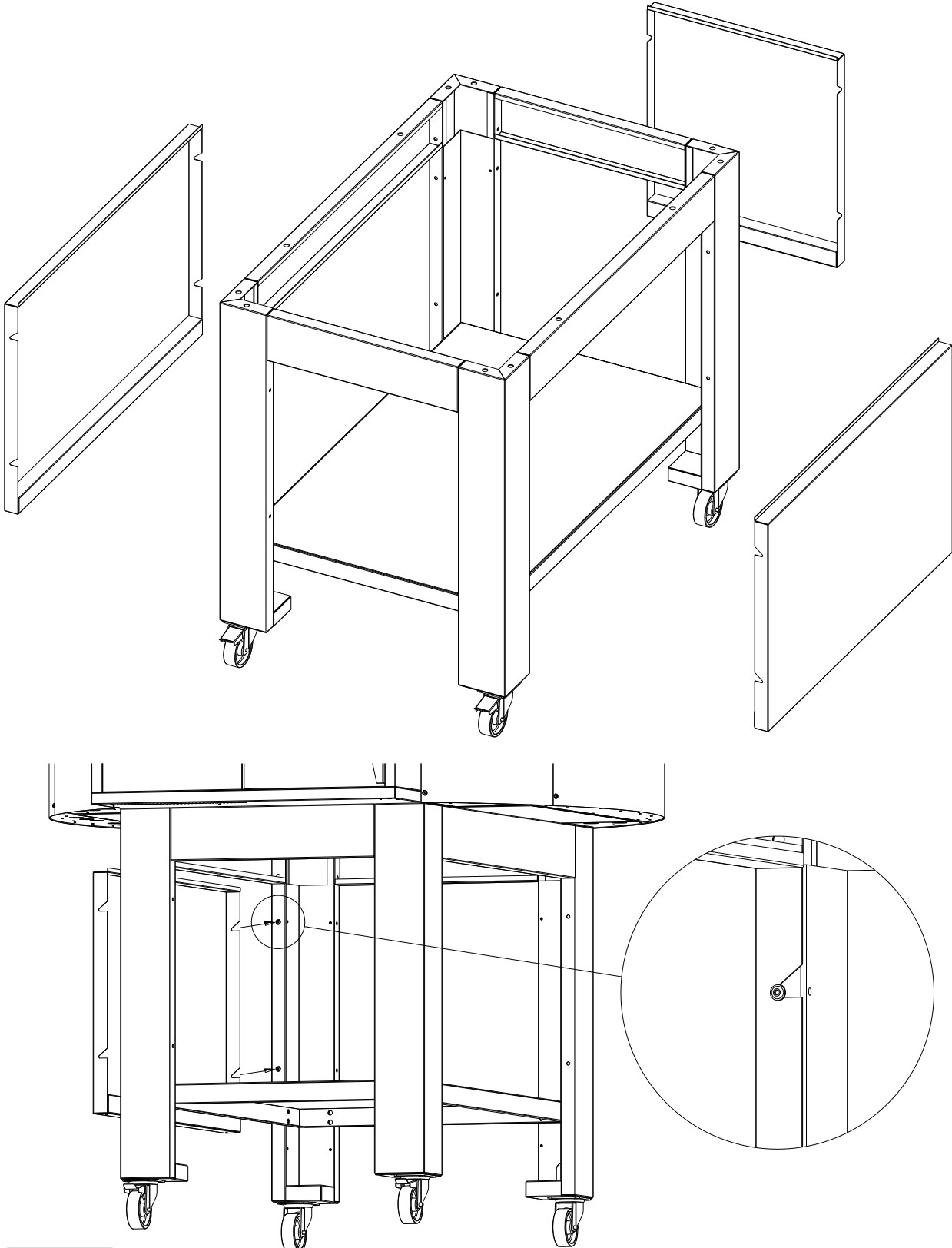

Fig.2

- 3- Secure the door support crosspieces to the legs, shelf and front crosspiece of the base with the screws on the legs (Fig.3).
- 4- Secure the upper hinges to the support crosspiece with the screws provided (Fig.4).
- 5- Assemble the lower hinges with the bushings on the doors; place it all on the supporting crosspieces and secure with the screws provided (Fig.4).

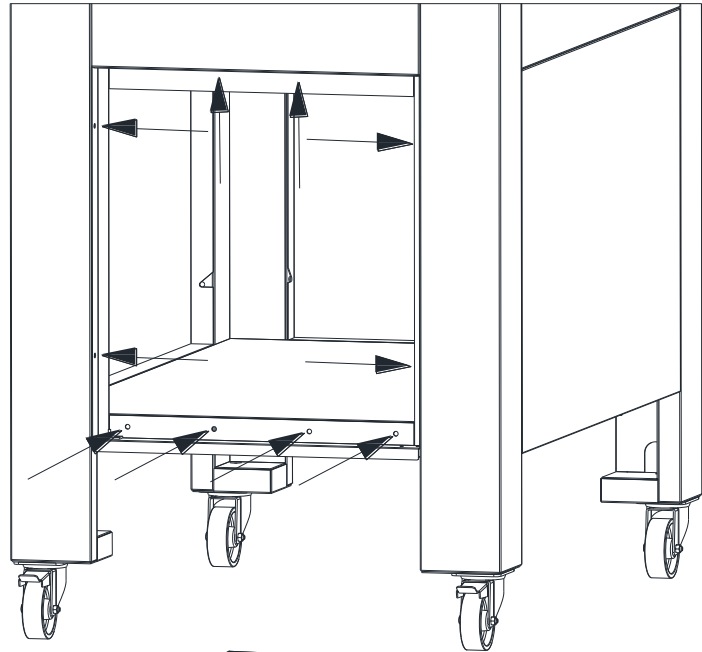

Fig.3

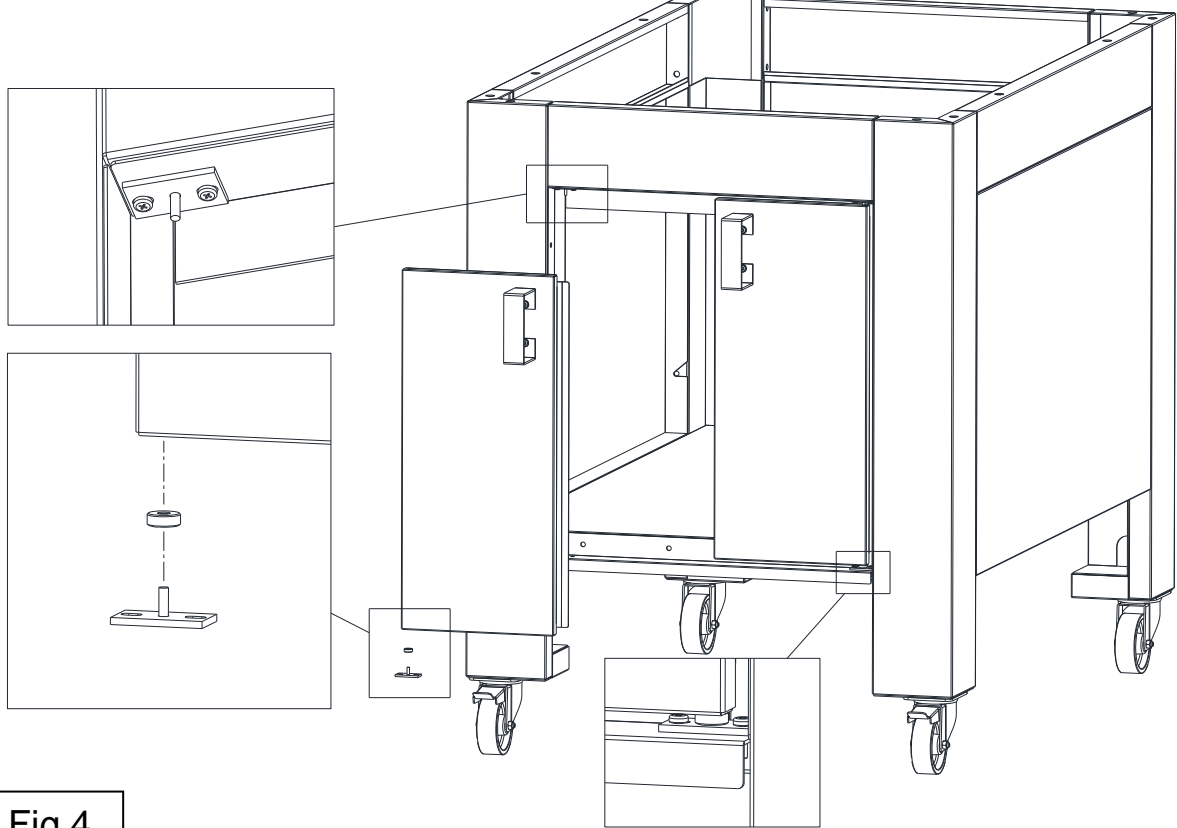



Fig.4

## 4.5. Electrical connection

 Before making any connection, check that the specifications of the electrical supply to which the equipment must be connected, correspond to the specifications of the power supply required by the apparatus itself (see Enclosure A).

 The appliances are supplied with an electric connection with ground/earth cable for connecting the appliance to the power grid according to the supply required (see Enclosure A).

In compliance with the safety norms in force. **It is obligatory to connect the ground/earth cable (yellow-green) to an earthing system with the same dispersion capacity as the appliance itself. The efficiency of this system must be correctly verified according to the norms in force.**

The power cable must terminate with a plug to connect to the electrical switchgear having a corresponding differential magneto thermal switch.

 **The equipment is not supplied with a power plug.**

The coupling between plug and socket must be such that the earth conductor is connected first and disconnected last and must have the right dimensions for the rated current (see Table 3.1). Plugs and sockets for industrial use of the type CEE17 are suitable or those which satisfy European norm EN 60309.

The thermal circuit breaker must be calibrated to the total rated current and the magnetic circuit breaker calibrated to the rated current (In the case of ovens this is only slightly higher than rated current), while the differential mechanism must be calibrated to the 30 mA current (see Enclosure A).

The electrical socket must be easily accessible and must not require further location after the installation of the equipment. The distance between the equipment and the socket must be sufficient to avoid stretching the power cable.

 **The power cable must never be trapped under the feet or wheels of the equipment**

 **If the power cable is damaged it must be substituted by customer support or by a qualified service engineer so as to avoid any risk.**

**The Manufacturer does not accept responsibility for damage caused by failure to observe the abovementioned norms.**

For the position of the power supply connections and the technical data information plate see Enclosure A.

## 4.6. Emissions from cooking appliance

 **ATTENTION!** Proceed with the installation of the oven according to the norms defined by current legislation in the country concerning the installation of this typology of oven so as to guarantee the sustainability of a healthy working environment. For more information it is recommended that specific norms be consulted.

 For the oven to work well, it is necessary to check that the exhaust system is drawing properly to expel vapors and cooking smells.

The oven has a 150 mm diameter natural type drain without a vacuum system.

 It is necessary to connect the drain to a centralized vacuum system.

The Manufacturer cannot answer for damage caused by ignoring these abovementioned norms as well as the information in this manual.

For the position of the vapor exhaust connections see Enclosure B.

## 4.7. Positioning the slabs of refractory material

 **Handle with care because the refractory material is fragile and could easily chip or even break.**

To position the refractory surfaces inside the oven carry out the following instructions whilst referring to the illustrations below:

### Standard refractory

- Insert the refractory floors of the floor into the oven (Fig. 1).
- Insert the left side refractory A into the frame B with the flat surface facing the inside of the chamber (Fig. 2).
- Insert the right-side refractory C into the frame D with the flat surface facing the inside of the chamber and the groove facing upwards to coincide with the hole in the frame to allow passage for the probe (Fig. 2).
- Insert the rear refractories E into the frames with the flat surface facing the inside of the chamber (Fig. 2).
- **Attention! Remove the temperature probe** (Fig. 3).
- Fold back and package close the two frames previously assembled with the refractories, then place them in a horizontal position and insert them into the chamber (Fig. 4).
- Inside the chamber, open the frames (Fig. 5) and place them resting on the sides and on the bottom of the chamber as shown (Fig. 6).
- Insert the first sky refractory with the flat surface facing the inside of the chamber and supporting the temporary support "C" located 200 mm away from the beginning of the chamber (Fig. 7). Repeat this operation for the other two refractories.
- Insert the refractory support beam into the two side brackets (Fig. 8).
- Gently remove the temporary "C" supports by lowering the refractories to support the support beam (Fig. 9).
- Put the temperature probe back in position A (see Fig. 3).

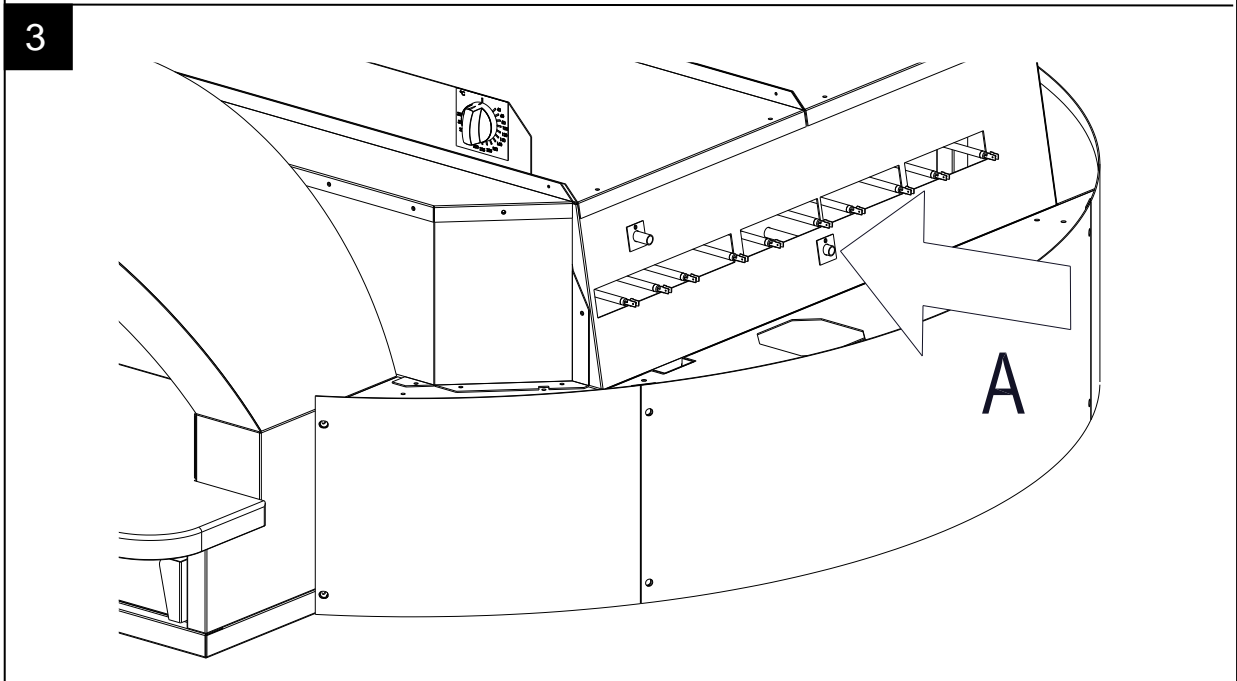
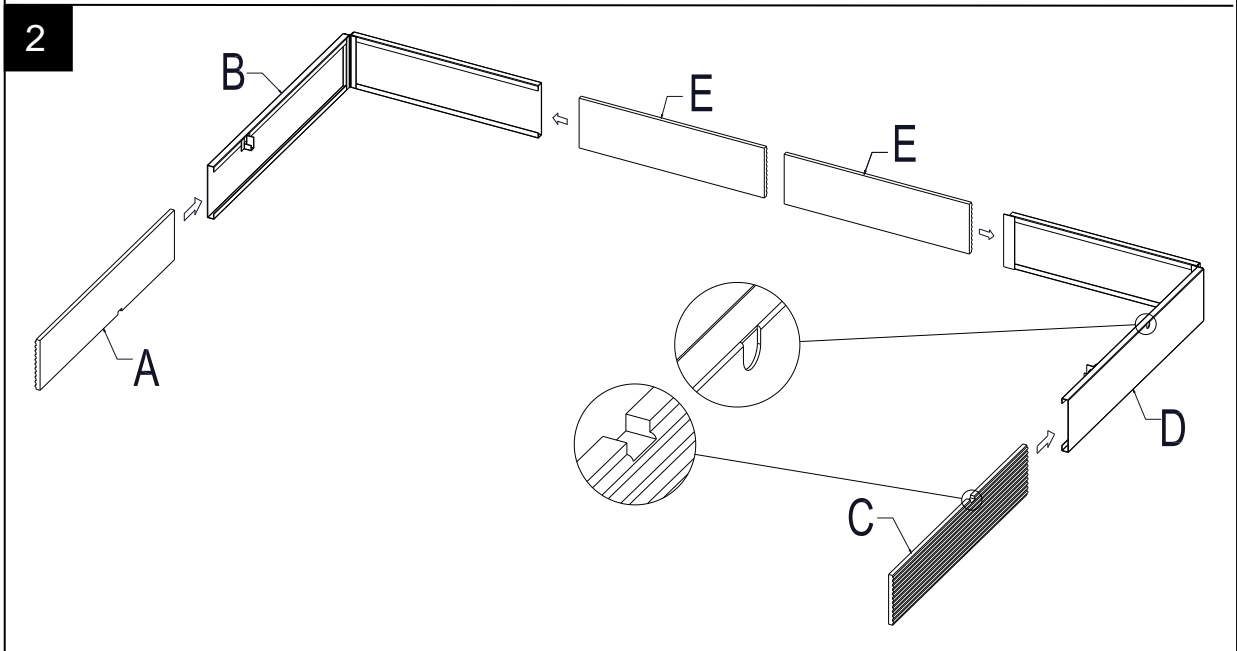
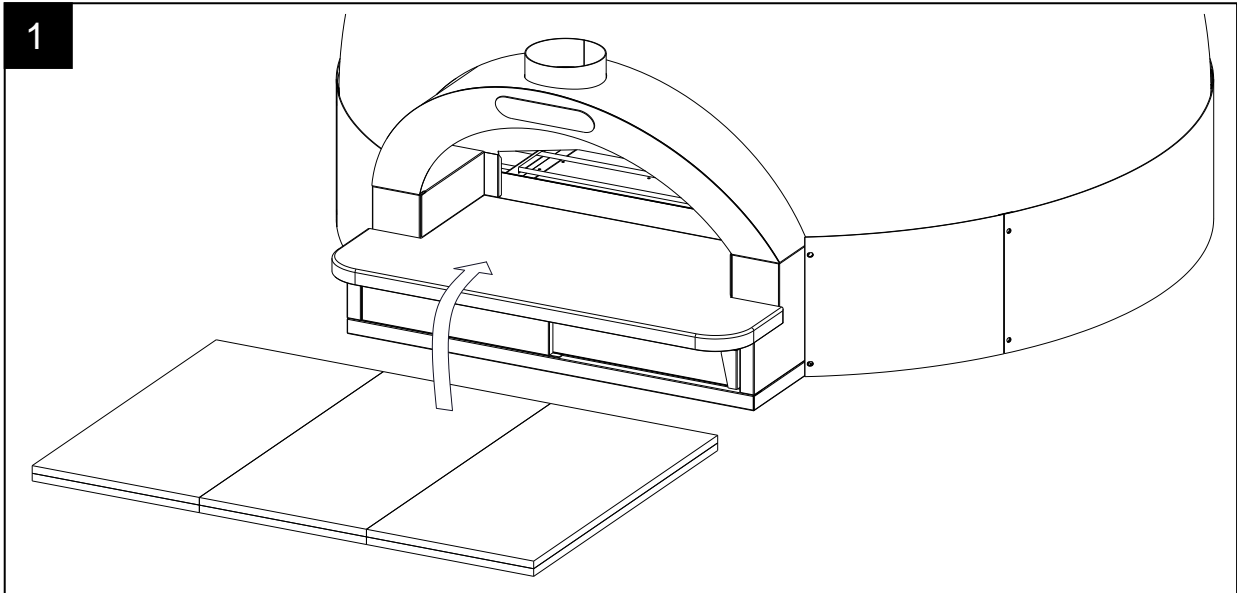

## 4. INSTALLATION

4

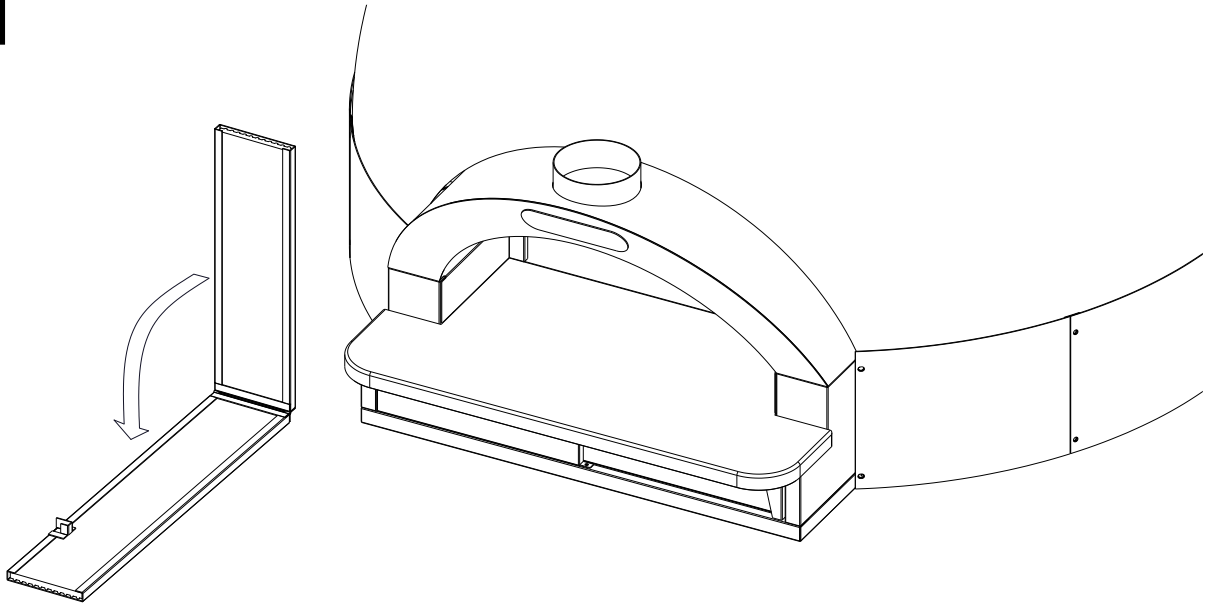

5

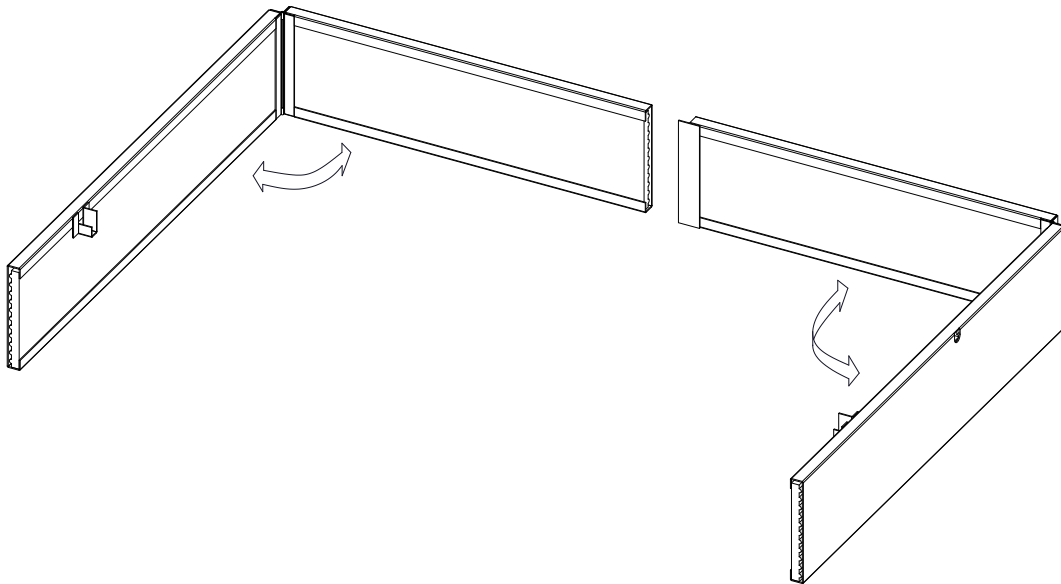

6

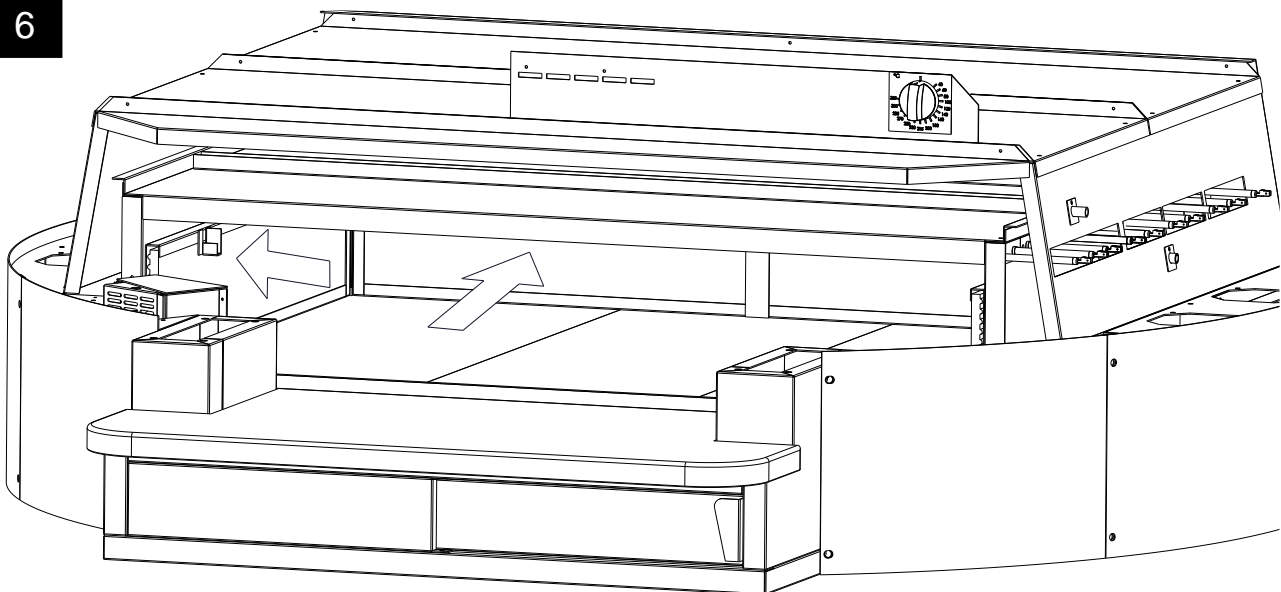

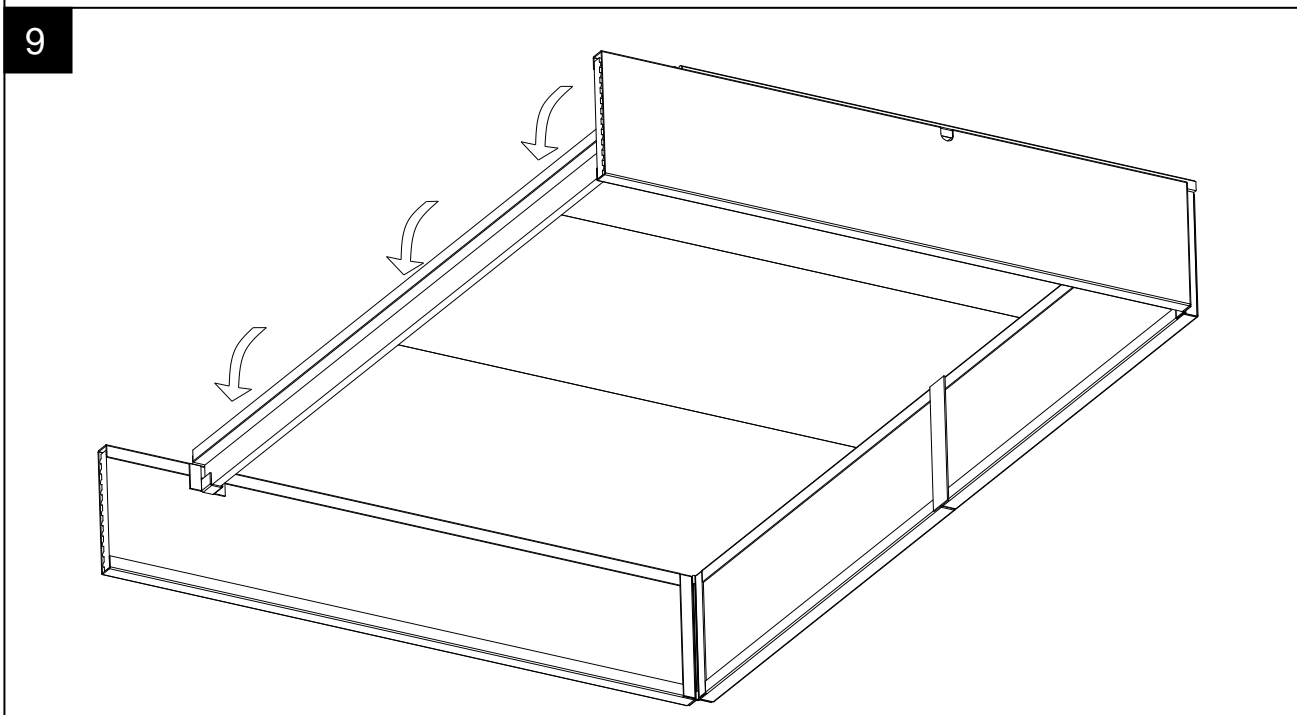
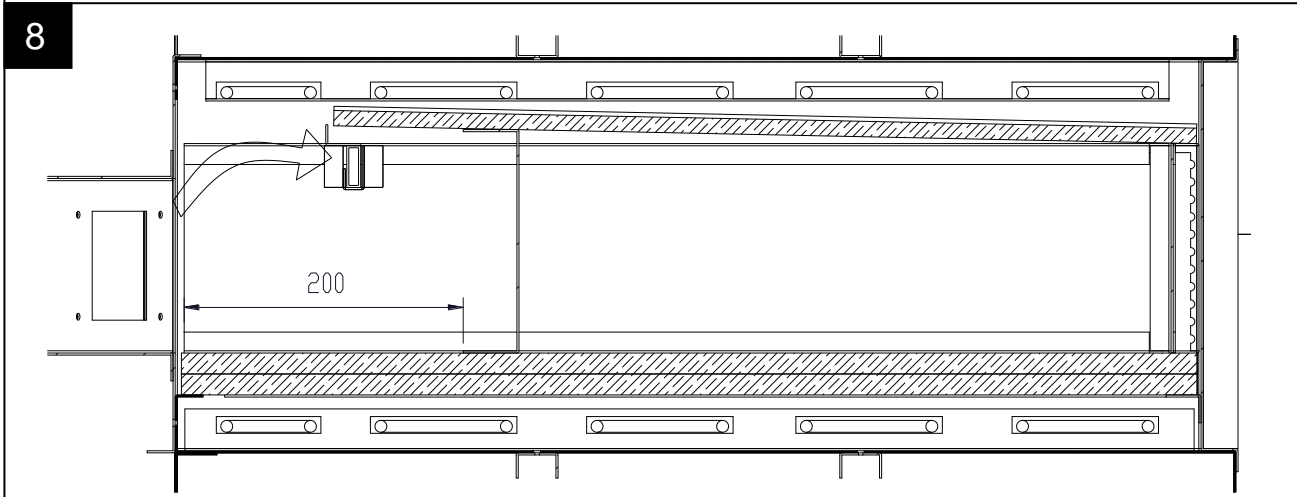
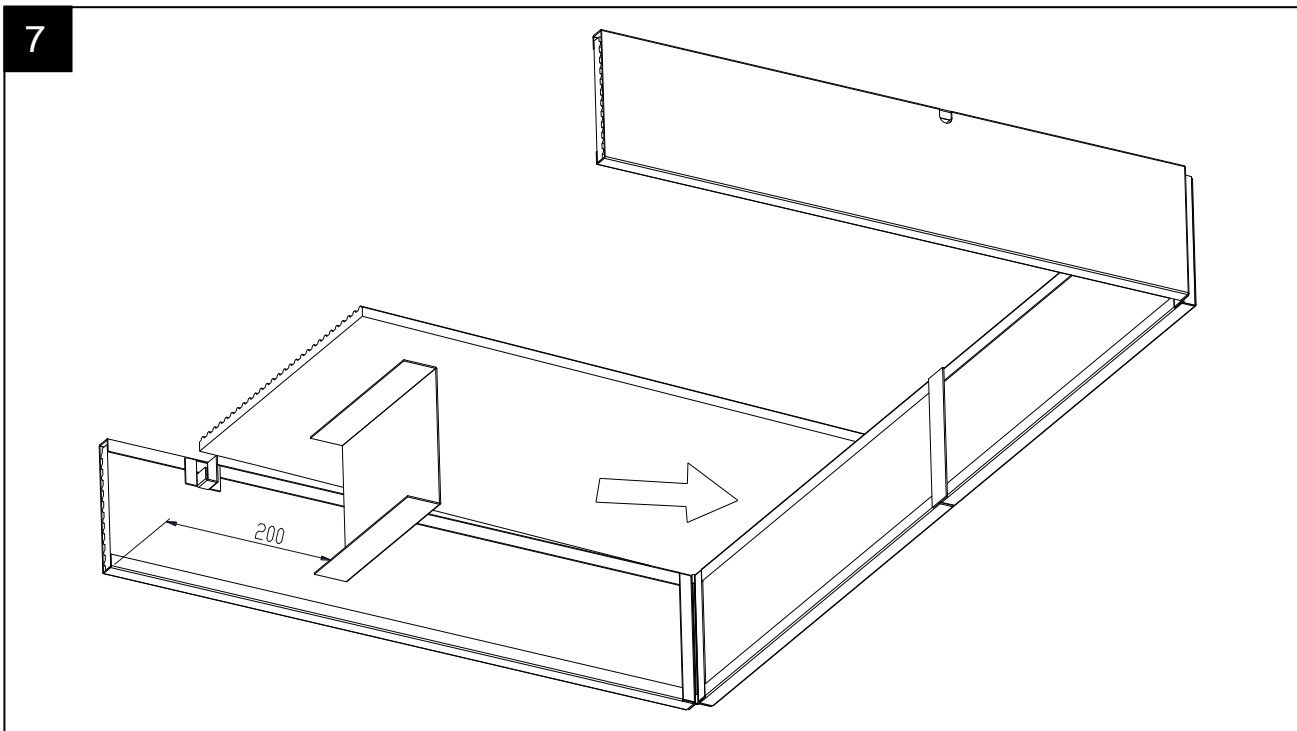

### Sorrento brick refractory pieces

- Insert the refractory floor support crosspieces into the oven; position them interlocking with the brackets on the bottom of the oven chamber and with the holes facing towards the front (Fig.10).
- Insert the refractory pieces into the oven in sequence 1-2-3-4-5-6-7-8-9 for the 6-pizza version and in sequence 1-2-3-4-5-6-7-8-9-10-11-12 for the 9-pizza version (Fig.11).
- Next, position the other side refractory pieces and the roof pieces as described and illustrated above.

10

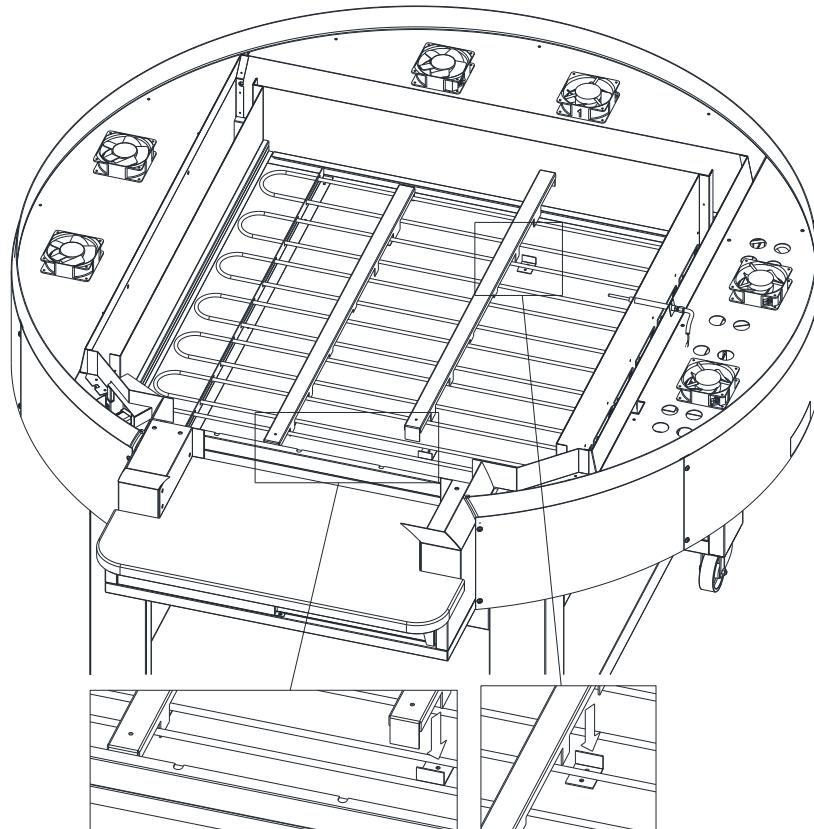

11

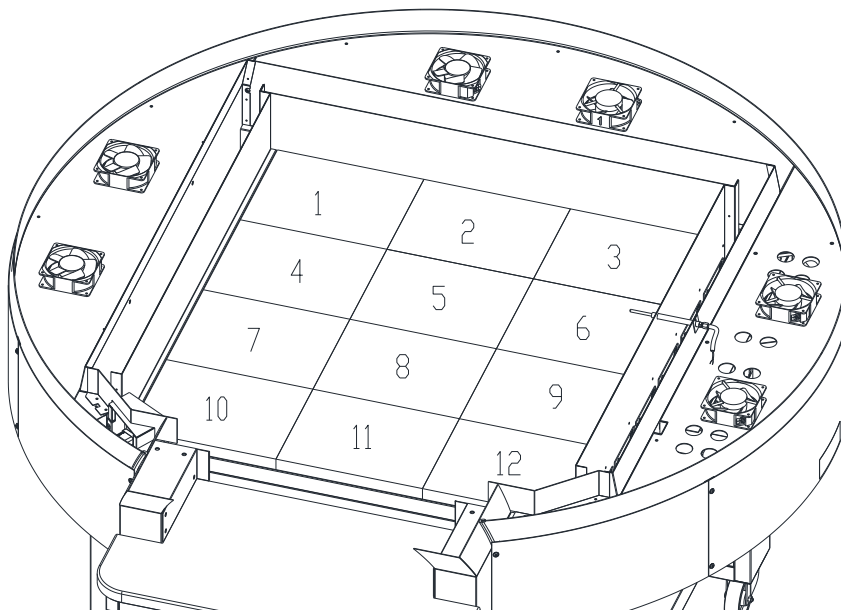

## 4.8. Checking before starting work

After completing installation of the unit a series of checks must be carried out, listed as follows:

- check that the various disassembled parts have been assembled
- check the power cable
- check that the control panel is working

### **IMPORTANT - PRE-HEATING PHASE AT FIRST IGNITION**

The components of the brand new oven (refractory stone bottom and metal parts) need to be pre-heated before being used for the first baking.

When the oven is switched on the first time, it is necessary to HEAT IT GRADUALLY IN ABOUT 5-6 HOURS (**1<sup>h</sup>=100°C - 2-3<sup>h</sup>=150°C - 4<sup>h</sup>=200°C - 5<sup>h</sup>=250°C - 6<sup>h</sup>=300°C**). The max temperature has to be reached at the end of this pre-heating phase.

This procedure is absolutely necessary to avoid damages to any part of the oven.

## 5. WORKING

### 5.1. Control panel

Figure 5.1. shows the control panel with all controls:

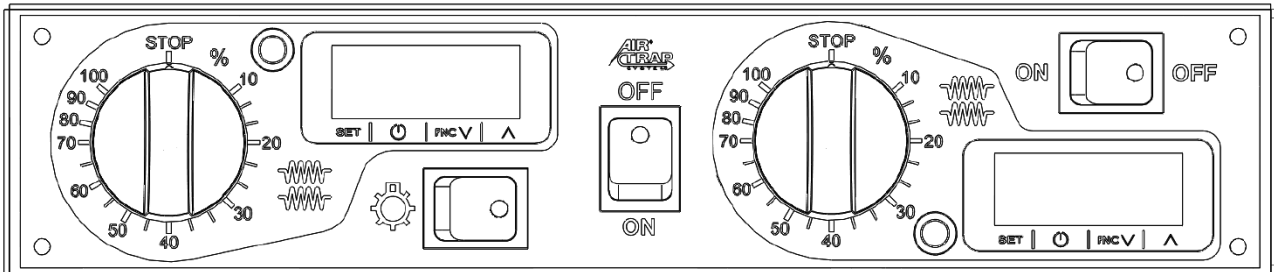

Fig.5.1. Control panel

#### 5.1.1. Temperature control

 Baking chamber temperature display

 Button SET e ESC

 Disabled button

 Button DOWN

 Button UP

“out1” led green display

#### 5.1.2. General

 Baking chamber light switch;

ON OFF Baking chamber on/off switch;

 “Air Trap System” switch.

#### 5.1.3. Power control

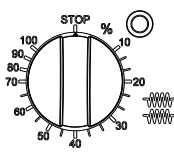
 Oven roof power regulator and light

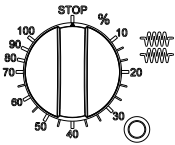

○ Oven bedplate power regulator and light.

## 5.2. Control description

### 5.2.1. **Main ON/OFF switch**

When this switch is OFF, all displays on the control panel are off. When it is ON, the switch itself and the thermostat turn on, so that it is possible to set the temperature. The baking chamber heating elements remain off as long as the  switch is off. When the switch is ON, it turns on and the baking chamber heating elements turn on according to the set temperature and power.

### 5.2.2. **Baking chamber light switch**

By setting switch on “on”, the switch and the chamber light turn on.

### 5.2.3. **“Air Trap System” switch**

*By turning this switch to the 'on' position, the switch itself and the 'Air Trap System' turn on.*

#### AIR TRAP SYSTEM SWITCH ON

- 1). *it optimises oven temperature maintenance;*
- 2). *it optimises the baking results even if the oven has no door;*
- 3). *it saves energy and increases the efficiency of the oven.*

#### AIR TRAP SYSTEM SWITCH OFF

- 1). *allows the temperature to drop faster, if required;*
- 2). *allows placing by the cooking chamber mouth products that require temperatures lower than the internal ones;*
- 3). *recommended for baking Neapolitan pizza; often during the baking of Neapolitan pizza, the pizza is moved from the front of the baking chamber to the rear, taking advantage of the temperature difference.*



### 5.2.4. **Temperature control** **Baking chamber temperature display**

In the normal operation mode, this display shows the cooking chamber temperature in °C.

In the temperature programming mode, this display shows the programmed temperature. This displays is also used to display some failures (5.3).

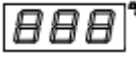

### 5.2.5. **Button**

Instantly tap the button once  to enter the temperature programming mode to set the "SP" set point.

The display  shows the wording "SP" and then shows the programmed temperature which can be changed using the  and  buttons.

If no buttons are pressed for more than 15 seconds, the thermostat automatically returns to the normal operation mode.

Once the desired temperature is set, press  to confirm and exit the temperature programming mode.

 **WARNING! do not hold down the  button for more than 5 seconds because the internal parameters of the thermoregulator may change with consequent unpredictable malfunctions.**

See Enclosure A for the range of temperatures that can be selected.

### 5.2.6. **Buttons** **and**

By pressing and releasing these buttons once, the set temperature increases or is reduced by one unit. Keeping them pressed in the temperature steadily increases or decreases, first slowly then more quickly.

### 5.2.7. **"out1" display led green**

The "out1" display led green turns on every time the baking chamber temperature is below the set temperature. It turns off when the cooking chamber temperature reaches the set temperature and goes on again when the baking chamber temperature goes 1° C below the set temperature. The green led "out1" is blinking when you enter into the program of the oven.

### 5.2.8. **Locking/unlocking the keyboard**

The keyboard locks automatically after 30s of no action on the thermoregulator buttons.

If the keyboard is locked you will not be allowed to:

- Modify the working setpoint with the procedure related in paragraph 5.2.5.

This operation provoke the visualization of label "**Loc**" 1 second.

To unlock the keyboard:

- Press  1 seconds: the display will show "**UnL**" 1 second.

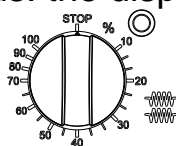

### 5.2.9. Power regulators

Each baking chamber has two power regulators, one connected to the oven roof heating elements, and the other one to the bedplate heating elements. These regulators ensure an even distribution of the heat inside the baking chamber so as to obtain an even cooking.

Each power regulator controls the power of its own heating element, regulating the start up time of the heating element within a range of 30 seconds.

If the power regulator is set on 10, its heating element will be on for 3 seconds and off for 27 seconds (provided the "out1" is on). If the power regulator is placed on 50, its heating element is on for 15 seconds and off for 15 seconds. When the power regulator is placed on 100, its heating element is always on (provided the "out1" display is on).

### 5.2.10. Oven roof and bedplate pilot lamps

Both oven roof and bedplate pilot lamps turn on when the "out1" display is on and its power regulator is switching on within the regulation cycle, to indicate that its heating element is actually on.

power regulation		
position	no. secs. to switch on	no. secs. to switch off
10	3	27
20	6	24
30	9	21
40	12	18
50	15	15
60	18	12
70	21	9
80	24	6
90	27	3
100	30	0

## 5.3. Error display

### 5.3.1. *Disconnected thermocouple*

When the thermocouple is disconnected or interrupted, the display shows "PR1".

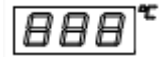

The same code of error appears if the baking chamber temperature exceeds the maximum temperature that can be selected.

## 6. USE



### 6.1. Preparation for use

 If the equipment has just been installed or has not been used for a number of days, before using it for food products, it is necessary to clean it thoroughly in accordance with the indications in chapter 7 to remove residual factory dirt, accumulations of dust or any other substances which could contaminate food products.

### 6.2. Ignition of the control panel

Turn the light switch on **ON OFF**, the control panel turns on and you can make all settings while the baking chamber is still off.

### 6.3. Settings

Set the required temperature by means of the keys ,  and  (see 5.2.5. and 5.2.6).

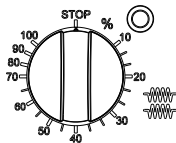
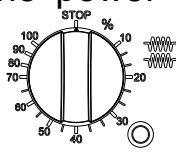
Set the power of the heating elements of the oven top  and bottom  (see 5.2.9).

### 6.4. Baking start

At this point turn on the light switch **ON OFF** and after a short time you will see that the temperature in the baking chamber starts to rise. If you have set the maximum temperature the oven will reach this in 40-45 minutes.

### 6.5. Loading the oven

 **WARNING:** when the chamber is heated up, the metal parts of the stovehole reach dangerous temperatures for the human body.

## 6.6. General indications for good cooking

It is not possible to say exact times and temperatures for food products in general given the enormous variations they are subject to.

As regards in particular pizzas and similar products, the cooking time and the temperature depend on the shape and thickness of the dough and the quantities of the ingredients added to it. We therefore advise that a few test runs are made, especially if you have never worked with this model of oven before, starting out with a temperature of 250-300°C and bearing in mind the following points:

1) Set the initial cooking parameters as recommended: ceiling 70%, floor 40% and temperature 320°C. These parameters can be modified according to the work in progress, the product to be cooked and other general requirements.

2) generally with lower temperatures a better quality and more digestible product is obtained, the oven is not subjected to particular stresses and lasts longer, though the cooking times become longer.

3) with higher temperatures it is more difficult to obtain even cooking but the cooking times are reduced.

4) just after loading the oven it is normal for there to be a fall in the temperature of the oven of as much as 20-30°C. This should not be considered a limitation of the oven but as a useful indication that at the beginning of cooking the water in the raw dough is evaporating and taking up a large quantity of heat. It is, however, always possible to set a higher temperature so that the oven reaches the desired temperature on loading. In any case if the oven is used within the limits of its maximum capacity, the temperature will start to rise again towards the end of the cooking time.

5) the oven has a maximum production capacity expressed **indicatively** in the characteristics in Kg of product per hour. If this production capacity is exceeded, the temperature of the baking chamber will fall even beyond 20-30°C. In such a case the excess quantity should be removed and you should wait until the desired temperature has returned before any further loading.

## 6.7. Turning off

At the end of the working day turn off the light switch , the cooling fans in the inner dome area can switch on and off automatically.

**NB** Close the stokehole to keep the heat inside the cooking chamber.

 During long periods of idleness (e.g. closures for holidays) it is advisable to switch off the main switch on the electrical feed panel.

## 7. CLEANING

⚠ At the end of each working day (or more frequently if possible) it is necessary to carefully clean the cooking surface and all the parts of the oven which come into contact with the food being cooked to avoid that any food substances go off and contaminate either the working environment or later products to be cooked.

⚠ Before cleaning is carried out, the oven should be turned off and at room temperature with the oven disconnected from the mains electricity supply by means of the mains switch on the switchgear.

### 7.1. Cleaning the exposed parts

⚠ The tempered glass parts are particularly sensitive to sudden variations in temperature that can cause them to crack into tiny fragments. **Do not handle glass parts and do not bring them into contact with water until they have cooled down to room temperature.**

⊘ It is not recommended to use abrasive tools (abrasive sponges or similar) because over time they take the shine off the stainless steel parts and high impact glass. The best idea is to wash the various removable parts before food residues have had time to dry up.

### 7.2. Cleaning the parts made from refractory material

To remove cooking residue from surfaces made from refractory material, use a brush. If residue is stuck to these surfaces, prise them off gently with a spatula.

⚠ Do not use any form of liquid especially detergent because the refractory material is porous and it cannot be rinsed to remove residue that comes into contact with these surfaces.

⊘ Do not use clearing tools which are too pointed or abrasive because the refractory material is fragile and could easily chip or even break.

### 7.3. Cleaning the oven's cooking chamber

To clean the aluminium coated sheet steel cooking chamber, use a soft moistened sponge and if needs be a weak non abrasive detergent, making sure not to let any cleaning liquids drip onto the refractory material.

If there is a consistent amount of fat deposited on the surfaces remove them first using a spatula.

⊘ Do not use abrasive or corrosive detergents because these will cause the stainless steel to become opaque and will, quite quickly, remove the protective layer of aluminum coated sheet steel, at which point it will start to rust.

⚠ Do not direct jets of water onto the equipment for clearing as these can penetrate through to and damage the electrical system with the consequent risk of electrocution and the equipment starting up unexpectedly.

### 7.4. Cleaning external surfaces

To clean the external surfaces made from either stainless steel or painted sheet metal as well as the control panel, use a soft moistened sponge and if needs be a weak non abrasive detergent.

⊘ Do not use abrasive or corrosive detergents because these will cause the stainless steel to become opaque and eventually remove the painted surface of sheet metal parts at which point they will start to rust.

⚠ Do not direct jets of water onto the equipment for clearing as these can penetrate through to and damage the electrical system with the consequent risk of electrocution and the equipment starting up unexpectedly.

## 8. MAINTENANCE

**⚠ WARNING:** These use and maintenance instructions are intended only for staff which is qualified for the installation and maintenance of electrical and gas equipment. Maintenance by other persons may cause damage to the equipment, persons, animals or things.

**⚠** In the majority of cases it is necessary to remove the fixed guards in order to carry out repairs and checks; this also renders the voltage cables accessible. **Before carrying out any maintenance operations, check that the equipment's feed cable plug is disconnected from the switchboard.**

### 8.1. Ordinary maintenance work

#### 8.1.1. *Light replacement*

Disconnect the plug from the electrical feed panel.

**⚠** The light is located in a part of the oven which has no heat insulation. This means that the external closing of that space reaches high temperatures when the oven is working.

**The light replacement should therefore be carried out only when the oven is cold, or using protective gloves.**

To change the lamp in the baking chamber, it is necessary to carry out the following steps:

**1** - Remove the front left half-round cover.

**2** - Remove the lamp holder by twisting off the 2 self-tapping screws.

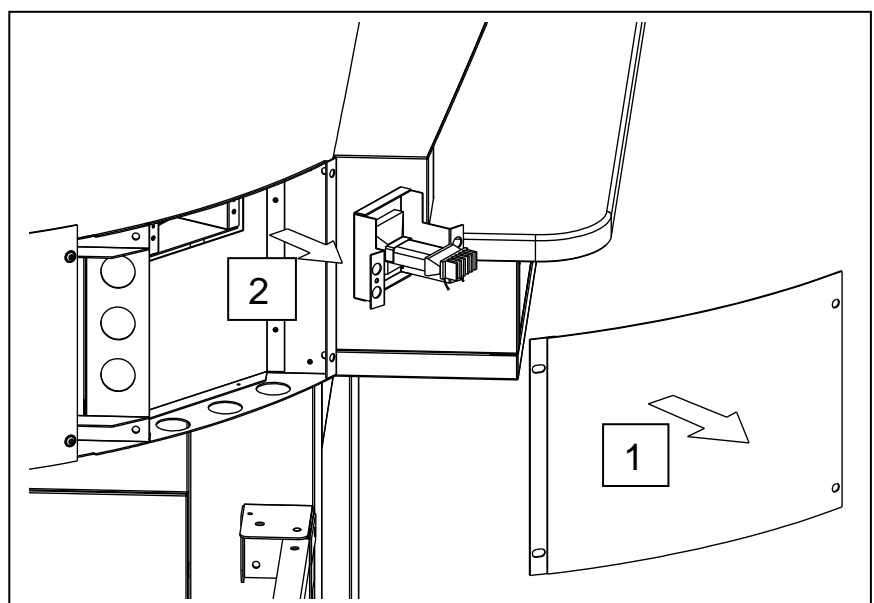

**3** - Press the locking tabs and remove the lamp from the lamp holder; then replace it with one that has the same features.

Reassemble all of the components in reverse sequence as described above.

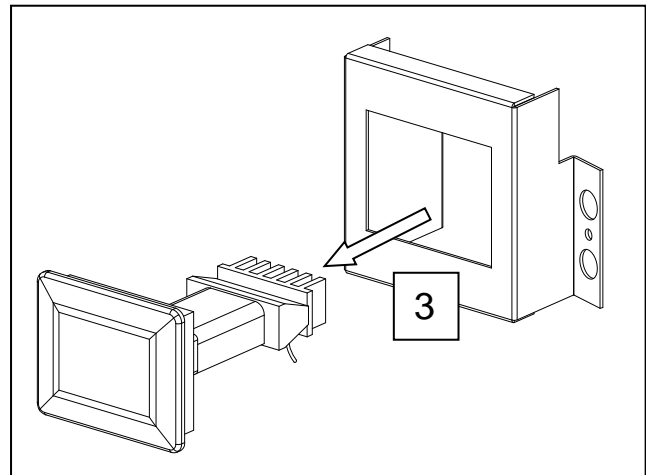

### **8.1.2. Tightness check of mains power connections**

For the oven's regular function and a longer duration of the electrical components, it is advisable to carry out a check of the tightness of the electrical power connections every six months as described below:

Remove the right side half-round cover (see 4.3.1) to get access to the electrical components. Check that the fixing screws of all contactors and terminal boards are not loose. If they are, tighten.

### **8.1.3. Control Panel cleaning**

Dust, flour and dirt in general can accumulate inside the oven's front and right-side areas, where the control panel and electrical components are located. Simple but frequent cleaning can guarantee the oven's proper function and a longer duration of all components. To this end, every six months, open the control panel front access door, remove it (4 screws) and vacuum clean the dust deposited on the electrical components. Remove the right side half-round cover and vacuum clean the dust deposits on the electrical components. Use a soft brush for the most critical spots.



Always use appropriate personal protection equipment for the maintenance work.

## **8.2. Safety thermostat**

The safety thermostat intervenes when the temperature in the chamber goes above 500°C and de-activates the resistors. The safety thermostat needs to be manually reset and is located in the electrical panel on the right side; see Annex D for the exact position.

To correct the error unplug the feed panel and wait for the chamber to cool down.

Remove the right-side cover and press the red button of the safety thermostat. You cannot reset the thermostat until the chamber's temperature has dropped below 500°C.

 Since the safety thermostat only intervenes where there are serious malfunctions, carefully check the oven's working and repair if necessary before starting up the oven again.

### **8.3. Error displays**

The oven running system is able to recognize some malfunctions; (see 5.3).

## 8.4. Electrical diagram

See Enclosure C.

## 8.5. Adjustment for different feed voltages

 **Warning!** To adapt the equipment to work at different feed voltages from that indicated on the initial set up label, three alterations have to be made:

- 1) to the cabling for the resistor wires.
- 2) to the cabling for the feed to the control panel.
- 3) to the application of a new label.

 **Carry out three alterations with care as otherwise the equipment may be unsafe.**

### 1) Wiring of heating elements wires

Pull the plug out of the electric supply board. Remove the right-side half-round cover. Disconnect all heating elements wires from the impulse relays and reconnect them according to the wiring diagram identified for the new electric supply (see electrical diagram Enclosure C).

### 2) The cabling for the feed to the control panel

Detach the BLUE wire from the lower remote-control switch and reconnect it as shown in electrical diagram Enclosure C.

### 3) Application of the new plate

Apply an indelible plate carrying the specifications of the new electric supply under the data plate.

## 9. DECOMMISSIONING AND DEMOLITION

Before decommissioning, disconnect the electrical supply and any other connections before proceeding to move the unit by a suitable means such as a forklift truck, hoist, etc. The ovens are composed of the following materials: stainless steel, varnished sheet steel, aluminum coated sheet steel, glass, refractory material, rock wool and electrical parts.



**Source separation for recycling. This product must not be disposed of together with normal domestic waste. Depending on local standards and conditions, services for collecting separated waste of RAEE may be available at centers provided by the local council.**