



**MOD : GTP-3/1R**

**Production code : LF03TE-GN11T**

**04/2026**

## *BLAST CHILLERS*

Installation and User Manual



**GTP-3/1R**

*These instructions apply to the following models:*

GTP-3/1R
GTP-5/2R
GTP-10/3R

## MANUAL VALIDITY

The figures show the LFT05TE model but the installation, use and maintenance instructions also apply to the other models, unless otherwise specified.

## EXPLANATION OF PICTOGRAMS

Please read this manual carefully before installing or using the equipment. There are some warning and danger symbols inside the manual:



Danger! Immediately dangerous situation. Dangerous situation that could result in injury or death.



Danger of electric shock!



Earthing symbol



Equipotential symbol



Read the instruction manual



Tips and useful information



I refer to another chapter

Partial reproduction is prohibited without the manufacturer's consent.  
The measurements provided are indicative and not binding.  
The original drafting language is Italian: the Manufacturer is not responsible for any translation/interpretation errors.

## DEAR CUSTOMER,

Dear customer, we congratulate you and thank you for choosing our equipment! This machine is able to quickly lower the temperature of food, thus making your work easier and maintaining the flavour and freshness of freshly cooked food over time.



This manual contains all the information necessary for the installation, use and maintenance of the appliance: we therefore recommend that you read it carefully before use and keep it safe for future reference.

## READY TO HELP YOU...

Using your device is simple and intuitive. This booklet contains all the information necessary for its use and maintenance, so you can start using it quickly and without any difficulty. However, if you require further information, we remain available to answer any questions you may have.

## INSTALLATION PART

SECTION DEDICATED TO QUALIFIED PERSONNEL AUTHORIZED BY THE MANUFACTURER, WITH ADEQUATE KNOWLEDGE OF THE PRODUCT

5

## USE PART



SECTION DEDICATED TO EQUIPMENT USERS

15



## SAFETY WARNINGS

This manual contains important information regarding the installation, use, and maintenance of your appliance and is an integral and essential part of the product. We invite you to read this manual carefully before proceeding with any operation to ensure your safety and avoid damaging the product.

- Keep this manual carefully for future reference and pass it on to the new owner if you sell the appliance, as the information it contains is intended for the purchaser and all those who, in various capacities, contribute to the installation, use, and maintenance of the product.
- The manufacturer declines all responsibility for damage caused by failure to comply with the installation, use and maintenance instructions indicated in the instruction manual, for unauthorized modifications to the product or for non-original spare parts.
-  Installation and extraordinary maintenance operations must be carried out by qualified personnel authorised by the Manufacturer, with adequate knowledge of the product and in compliance with the regulations in force in the country of use relating to systems and workplace safety.
-  Before installing the equipment:
  - verify that the systems comply with the regulations in force in the country of use;
  - always compare the system data with those of the appliance shown on the data plate;
  - The data plate provides important technical information that is essential in the event of a maintenance or repair request to the equipment. Therefore, it is recommended not to remove, damage, or modify it. Failure to comply with these instructions may cause damage and even fatal injury, voids the warranty, and releases the company from any liability.
  - Interventions, tampering or modifications not expressly authorised that do not comply with the instructions in this manual will void the warranty and may cause immediate or dangerous situations that could cause injury or death.
  - During the assembly of the equipment, the transit or presence of persons not authorised to carry out the installation near the work area is not permitted.
  - The packaging material, as it is potentially dangerous, must be kept out of the reach of children or animals and disposed of correctly in accordance with the regulations in force in the country of use.
  - The appliance can be used by children aged 8 years and above and by persons with reduced physical, sensory, or mental capabilities, or lack of experience and knowledge, provided they are supervised or have received instructions on how to use the appliance safely and understand the inherent hazards. Cleaning and user maintenance must not be carried out by children without supervision.
  - These appliances can be used for chilling, freezing, and keeping foods cold. Any other use is not compliant with the intended use and is therefore dangerous.
-  If the appliance does not work or you notice functional or structural alterations, disconnect it from the electricity and water supplies (if present) and contact a service center authorized by the manufacturer without attempting to repair it yourself. Always request the use of original spare parts.
- Do not cover the ventilation slots on the front panel.

## INSTALLATION PART

SECTION DEDICATED TO QUALIFIED PERSONNEL AUTHORIZED BY THE MANUFACTURER, WITH ADEQUATE KNOWLEDGE OF THE PRODUCT

TECHNICAL DATA LF03TE - GTP-3/1R	6
TECHNICAL DATA LF05TE - GTP-5/1R	7
TECHNICAL DATA LF10TE - GTP-10/1R	8
EQUIPMENT CONTROL	10
TRANSPORT	10
POSITIONING	10
ELECTRICAL CONNECTION	11
CONNECTION TO THE DRAIN (ONLY MODELS WITH PREDISPOSITION)	12
READING THE SERIAL NUMBER PLATE	12
WIRING DIAGRAM 3T	13
WIRING DIAGRAM 5T-10T	14

## TECHNICAL DATA

### LF03TE GTP-3/1R

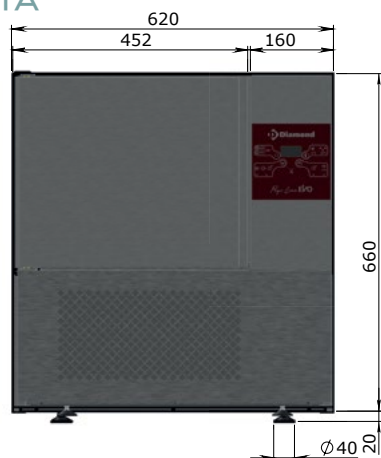

DIMENSIONS (L x P x H)	620 x 655 x 680 mm
WITH EMBALLAGE (L x P x H)	640 x 675 x 815 mm
WIDTH DOOR LIGHT	355 mm
HEIGHT DOOR LIGHT	281 mm
THICKNESS	55 mm
CLIMATE CLASS	4
BLAST CHILLING CAPACITY	8 Kg
FREEZING CAPACITY	5 Kg
POWER INPUT	710 W
CATERING LAYOUT	3 GN 1/1
BAKING LAYOUT	-
PAN CLEARANCE	70 mm
NET WEIGHT	43 Kg
GROSS WEIGHT	70 Kg
POWER CABLE	16A EU PLUG
POWER SUPPLY	230 v - 1/50 Hz
DRAINAGE HOSE	-
CYCLE CONTROL: TIMED	Si
CYCLE CONTROL: SENSOR PROBE	Si
EXTERIOR	AISI 304 finitura SB
encumbranc e	0.35 m3

Temp. evap. -10°C, temp. cond. +45°C / Evap. temp. -10°C, cond. temp. +45°C

## TECHNICAL DATA

### LF05TE GTP-5/1R

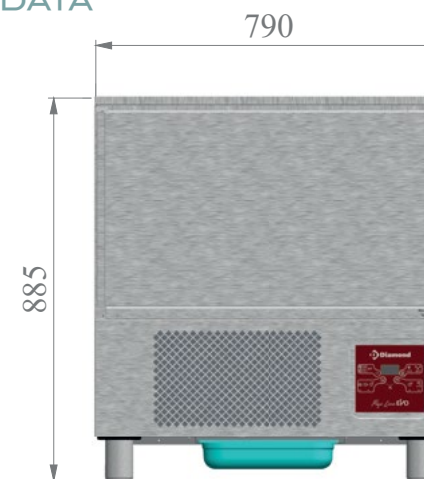

DIMENSIONS (L x P x H)	790 x 700 x 885 mm
WITH EMBALLAGE (L x P x H)	810 x 720 x 1020 mm
WIDTH DOOR LIGHT	680 mm
HEIGHT DOOR LIGHT	380 mm
INTERIOR DEPTH	415 mm
THICKNESS	60 mm
CLIMATE CLASS	4
BLAST CHILLING CAPACITY	16 Kg
FREEZING CAPACITY	8 Kg
POWER INPUT	921 W
CATERING LAYOUT	5 GN1/1
BAKING LAYOUT	5 EN 600x400
PAN CLEARANCE	65 mm
NET WEIGHT	70 Kg
GROSS WEIGHT	106 Kg
POWER CABLE	16A EU PLUG
POWER SUPPLY	230 v - 1/50 Hz
DRAINAGE HOSE	Ø ½"
CYCLE CONTROL: TIMED	Si
CYCLE CONTROL: SENSOR PROBE	Si
EXTERIOR	AISI 304 finitura SB
encumbranc e	0.6 m3

Temp. evap. -10°C, temp. cond. +45°C / Evap. temp. -10°C, cond. temp. +45°C

## TECHNICAL DATA

### LF10TE

### GTP-10/1R

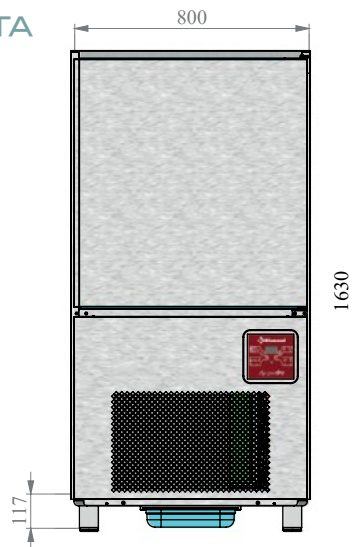

DIMENSIONS (L x P x H)	800 x 825 x 1630 mm
WITH EMBALLAGE (L x P x H)	820 x 850 x 1775 mm
WIDTH DOOR LIGHT	680 mm
HEIGHT DOOR LIGHT	770 mm
INTERIOR DEPTH	470 mm
THICKNESS	60 mm
CLIMATE CLASS	4
BLAST CHILLING CAPACITY	30 Kg
FREEZING CAPACITY	20 Kg
POWER INPUT	1390 W
CATERING LAYOUT	10 GN 1/1
BAKING LAYOUT	10 EN 600x400
PAN CLEARANCE	65 mm
NET WEIGHT	125 Kg
GROSS WEIGHT	153 Kg
POWER CABLE	16A EU PLUG
POWER SUPPLY	230 v - 1/50 Hz
DRAINAGE HOSE	Ø ½"
CYCLE CONTROL: TIMED	Si
CYCLE CONTROL: SENSOR PROBE	Si
EXTERIOR	AISI 304 finitura SB
encumbranc e	1.16 m3

<sup>1</sup>Temp. evap. -10°C, temp. cond. +45°C / Evap. temp. -10°C, cond. temp. +45°C

## EQUIPMENT CONTROL

After unpacking the equipment, check its integrity, verifying that it has not suffered any damage during transport. In the event of damage, note the equipment data on the rating plate (Fig. 1) and promptly notify the carrier/manufacturer.

## TRANSPORT

The equipment must be transported using personal protective equipment and a forklift (Fig. 2).

**!** Handle the equipment taking all necessary precautions to avoid damaging it and to avoid causing harm to people or things, respecting the instructions on the packaging.

**!** If the appliance was placed on its side during transport or kept at a temperature below 10°C, wait at least 4 hours before turning it on.

## POSITIONING

Transport the equipment to its location and level it using the feet (Fig.3).

**💡** When handling the equipment, it is advisable to use clean cotton gloves, avoiding leaving fingerprints.

The installation location must:

- have good ventilation and not be exposed to atmospheric agents;
- have a temperature between +16 and +30 °C and humidity not exceeding 55%;
- have a smooth, level floor capable of supporting the weight of the fully loaded equipment;
- comply with current regulations regarding workplace and plant safety;
- be dedicated to preparing food.

When choosing the location, also make sure that there is enough space for the door to open.

**!** The appliance must be installed so as to have easy access to the electrical and water connections (if present). Extension cords or cables cannot be used to lengthen the power cord: take the position of the sockets into account when positioning the appliance.

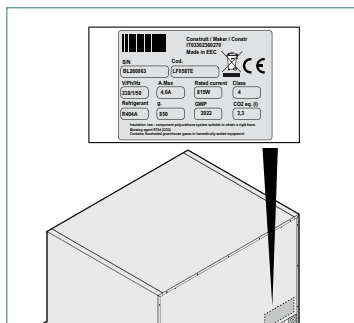

Fig. 1.

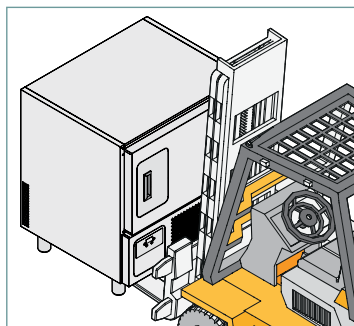

Fig. 2.

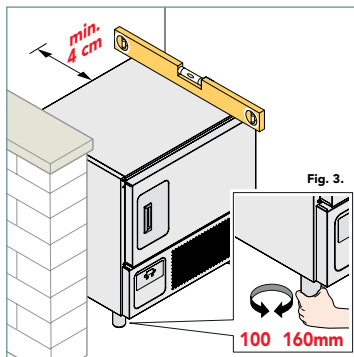

Fig. 3.

**!** Do not place the appliance near flammable materials or containers (e.g. partition walls, gas cylinders, etc.).

**!** Do not place the appliance near hot appliances (e.g. fryers, etc.).

**!** For proper air exchange, it is mandatory to leave a rear space of approximately 4 cm free from objects and walls (Fig. 4).

## PREPARATION

Remove the protective film (Fig. 4): clean any glue residue with soapy water without using tools that could damage the surfaces or abrasive or acidic detergents.

**♻️** All packaging components and the protective film must be disposed of in accordance with the regulations in force in the country where the appliance is used. In any case, nothing should be disposed of in the environment.

**!** Packaging components may be potentially dangerous to children and animals.

## ELECTRICAL CONNECTION

**!** Before connecting the appliance to the electrical network:

- read the safety warnings on the first pages of this manual;
- ensure that pre-existing electrical systems comply with the regulations in force in the country of installation;
- make sure that the pre-existing electrical systems comply with the equipment to be installed (see the data on the rating plate).

**🔍** See the chapter Reading the Serial Number Plate on page 12 for further information on the serial number plate.

The devices are supplied with a pre-assembled power cable: provide for an appropriate connection to a wall switch (Fig. 5).

The cable cannot be replaced or modified. If it is damaged, do not connect the appliance: contact an authorised service centre to replace it with one of the same characteristics.

**!** If the power cord is very long, DO NOT coil it and ensure it does not become an obstacle or hazard to operators. Also, ensure it does not come into contact with liquids, sharp/hot objects, or corrosive substances.

**!** When there are multiple appliances in the same room, it is mandatory to provide an equipotential connection using the appropriate terminal marked with the symbol

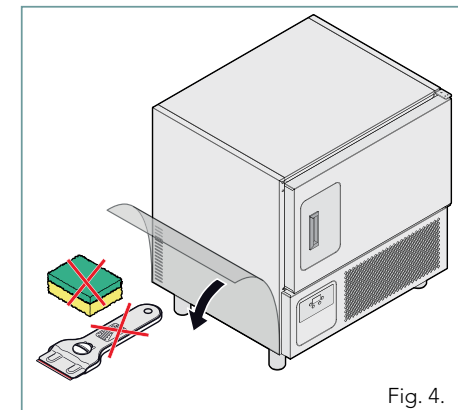

Fig. 4.

### DISCONNECTOR FEATURES

The disconnecter must be easily accessible and installed in the system in accordance with the regulations in force in the country where the equipment is installed. This disconnecter must have contact separation in all poles to ensure complete disconnection under over-voltage category III. Proper grounding is mandatory, and the ground wire must not be interrupted under any circumstances by the circuit breaker.

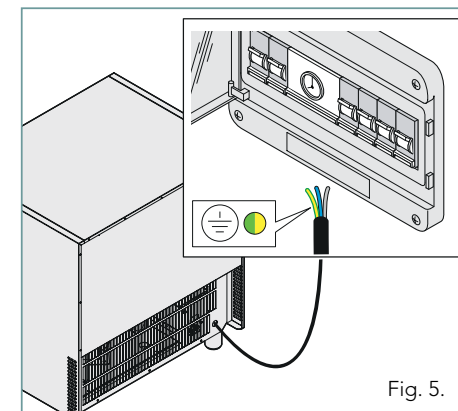

Fig. 5.

This terminal allows you to connect a yellow/green cable with a cross-section between 2.5 and 10mm<sup>2</sup>.

The effectiveness of the equipotential system must be appropriately verified as reported in the current legislation.

## CONNECTION TO THE DRAIN (ONLY MODELS WITH PREDISPOSITION)

At the bottom of the appliance there is a pipe from which the waste water comes out.

it is possible to use the guides provided to install a Gastronorm GN1/1 container (NOT supplied - can be purchased as an optional) to collect the water (Fig. 7), or, if there is a drain, connect directly to it.

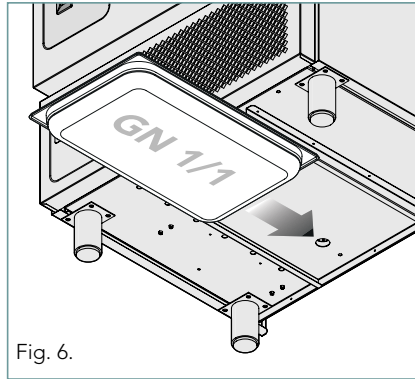

Fig. 6.

## EXHAUST PIPE FEATURES

The discharge must:

- be of the siphon type;
- be no longer than one metre;
- have a minimum gradient of 4%;
- have a diameter NOT smaller than that of the exhaust connection;
- dedicated to each piece of equipment; otherwise, make sure that the main pipe is sized to ensure regular and unobstructed flow;
- have no bottlenecks.

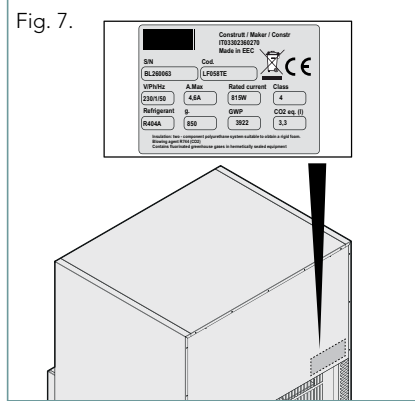

Fig. 7.

## READING THE SERIAL NUMBER PLATE

The data plate provides important technical information that is essential in the event of a maintenance or repair request to the equipment. Therefore, it is recommended not to remove, damage, or modify it. Failure to comply with these instructions can cause damage and even fatal injuries, voids the warranty, and releases the company from any liability.

Code	BL260063	LF058TE
Series No.	BL260063	LF058TE
Voltage	230/1/50	4,6A
Type of gas	R404A	850
Amount of gas	850	3922
Global warming potential	3,3	
Max. power absorbed	815W	
Climate class	4	
CO2 equivalent	3,3	
Rated current	4,6A	

## LF03TE GTP-3/1R

### WIRING DIAGRAM SCHEMA ELETTRICO SCHEMA DE CÂBLAGE

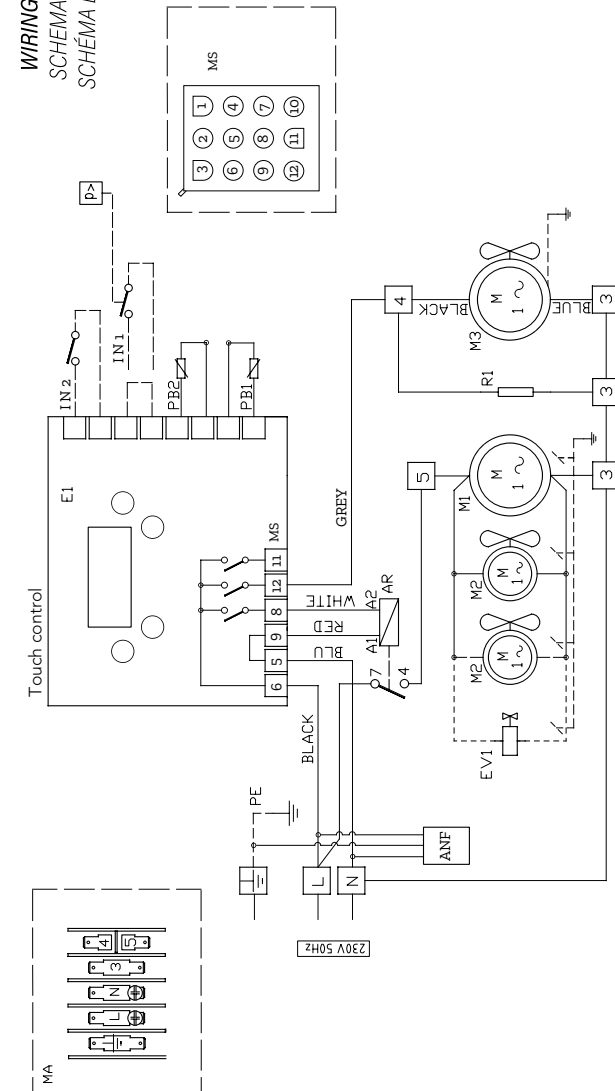

	DESCRIPTION	DESCRIPTION	
E1	Power electronic board	AR	Auxiliary relay
M1	Compressor motor	R1	Frame resistance
M2	Condenser fan motor	IN1	Pressure switch
M3	Cell fan motor	PB1	Pin temperature probe
MA	Terminal block connection	PB2	Cell temperature probe
EV1	Solenoid valve	ANF	Anti-noise filter FC790Y2F
MS	Terminal board	IN2	Micro port

**WIRING DIAGRAM**  
SCHEMA ELETTRICO  
SCHEMA DE CÂBLAGE

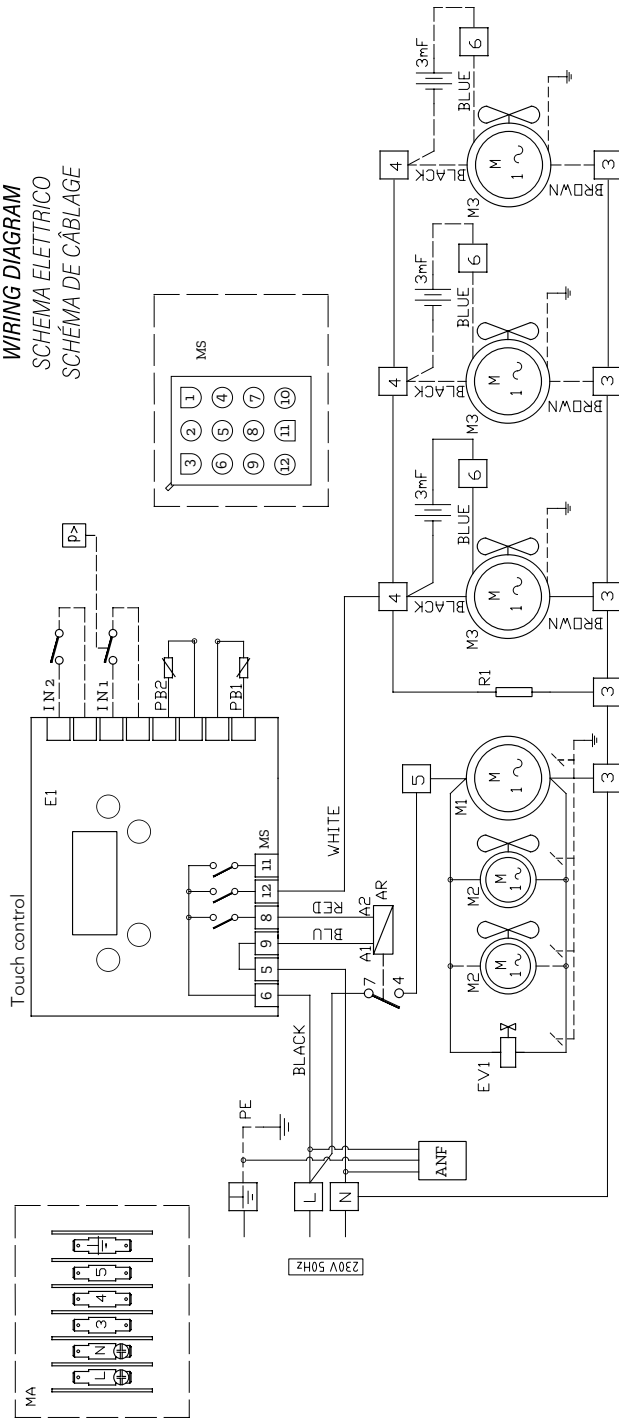

**LF05TE**  
**GTP-5/1R**

**LF10TE**  
**GTP-10/1R**

**USE PART**

SECTION DEDICATED TO EQUIPMENT USERS

USE	16
BLAST CHILLING 3°C FREEZING -18°C	17
CONTROL PANEL	19
SPECIAL FUNCTIONS	23
MAINTENANCE	24
AFTER-SALES ASSISTANCE	26

DESCRIPTION	DESCRIPTION
E1 Power electronic board	AR Auxiliary relay
M1 Compressor motor	R1 Frame resistance
M2 Condenser fan motor	IN1 Pressure switch
M3 Cell fan motor	PB1 Pin temperature probe
MA Terminal block connection	PB2 Cell temperature probe
EV1 Solenoid valve	ANF Anti-noise filter FC790Y2F
MS Terminal board	IN2 Micro port

## USE

Before use, read all safety warnings on the first pages of this manual.

This equipment is capable of performing:

- a positive drop to +3°C
- freezing at -18°C
- cooling the bottles
- keeping food cold

## IGNITION

Fig. 8. Power up the equipment.

To activate the standby screen, touch the center of the screen for 1 second. Touch the center of the screen again to go to the welcome page. Whenever the screen goes into standby, tap the center of the screen to access the main screen. When the device is subsequently turned on (for example, after a blackout), the device's status changes based on its state before the power outage.

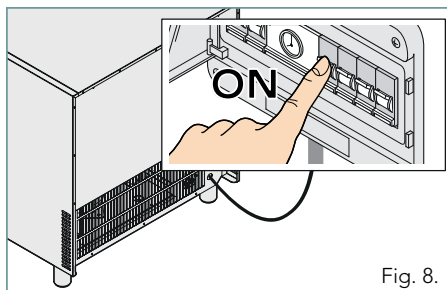

Fig. 8.

Equipment status BEFORE the power failure	Equipment status when power is restored
stationary equipment	stationary equipment
equipment in operation (cycle in progress)	the interrupted cycle starts again from zero

## WHAT IS A NEEDLE PROBE AND HOW IS IT USED?

The core probe or core probe is a tool supplied with the equipment: it measures the core temperature of the food to be treated.

When it reaches the required temperature, the blast chilling or freezing cycle ends and the food moves on to the negative preservation phase.

Fig. 11. The core probe must be inserted into the food before starting the desired cycle. Remove the core probe from the food before removing the trays from the appliance and position it so that it is not in the way.

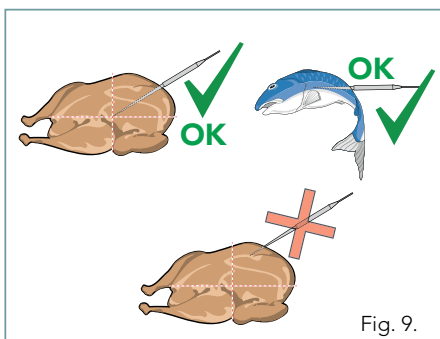

Fig. 9.

## 3°C REDUCTION FREEZING -18°C

### SOME INFORMATION

This appliance, unlike standard refrigerators and freezers, can rapidly lower the temperature of fresh or cooked foods to +3°C (blast chilling) or -18°C (deep freezing) as needed. This way, when they are regenerated for serving, they will retain their organoleptic qualities and flavor over time, as if they were freshly prepared, while also preventing the multiplication of microorganisms that are potentially dangerous to humans.

Over time, foods tend to dehydrate, meaning they lose moisture and consequently their softness and juiciness. For this reason, avoid keeping cooked foods to be blast chilled and/or frozen at room temperature for long periods. Begin the blast chilling or freezing cycle as soon as cooking is complete by placing the food in the appliance. Cooked food can be placed in the appliance even at very high temperatures, as long as the compartment is pre-cooled.

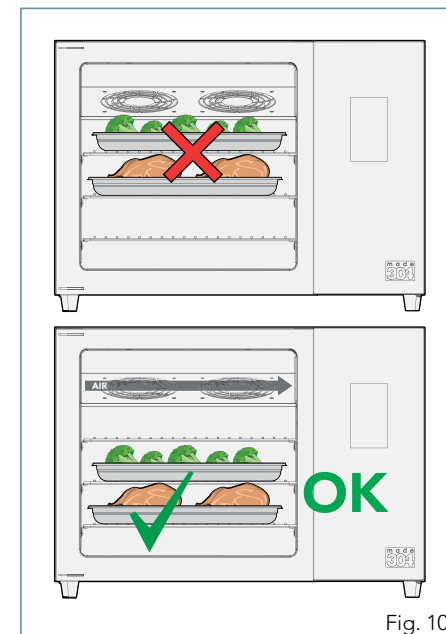

Fig. 10.

## HOW AND HOW MUCH SHOULD I LOAD THE BLAST CHILLER?

Fig. 10. Insert trays starting from the bottom and then use the higher spaces to ensure good air circulation. Load foods evenly, never overlapping them, and always respect the load capacity of your appliance, without overloading it. To check the chilling capacity and the freezing capacity, consult the technical data of the product purchased on pages 6-9.

## WHAT CONTAINERS SHOULD I USE?

Use containers suitable for contact with food, with low edges and resistant to low temperatures. Do not cover trays and containers containing food with lids or insulating film; the greater the surface area of the food exposed to cold air, the shorter the cooling time.

Fig. 11. After chilling or freezing, store food, marking it with a label indicating the contents, preparation date and expiry date.

The conservation of a food positively chilled (+3°C) takes place in the refrigerator at a temperature of 0/+3°C where the chilled food retains

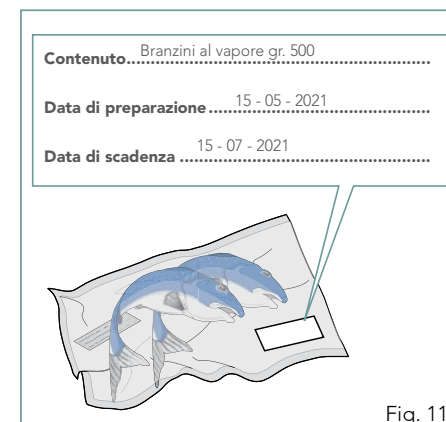

Fig. 11.

its goodness for up to 5 days. Frozen food (-18°C) is stored in a freezer at a constant temperature of -20°C, where frozen food can be kept for 3 to 12 months depending on the product.

### WHAT HAPPENS IF I DON'T REMOVE THE BLAST CHILLED OR FROZEN FOOD IMMEDIATELY AT THE END OF THE CYCLE?

At the end of each blast chilling or freezing cycle, a HOLDING PHASE of the products automatically begins (at +3°C or -18°C depending on whether the food has been blast chilled or frozen) to keep them at the right temperature until they are removed, which must occur as quickly as possible.

### HOW LONG DO FOODS KEEP IN THE FREEZER AFTER BEING FROZEN?

The shelf life of food varies depending on the type of food, so the table on the side is indicative.

The vacuum system increases the shelf life of chilled foods by up to 15 days. Vacuum packing must be performed in strict compliance with time and temperature regulations.

### HOW SHOULD FISH TO BE EATEN RAW BE TREATED?

Raw fish, i.e., uncooked fish, must be properly treated before consumption to eliminate any *Anisakis simplex* larvae, a parasite that may be present on fish products that are not sufficiently cooked or served raw. If the larvae penetrate the gastric mucosa, they cause abdominal pain and, in severe cases, serious complications.

Place the raw fish in the blast chiller and run an automatic freezing cycle (see page 21) by selecting the fish icon.

Once the cycle is complete, the frozen fish should be placed in the freezer for at least 24 hours before consumption. After this waiting period, proceed with thawing: the fish is now ready to be consumed raw, completely safely.

This mode (blast chiller + freezer) uses fast freezing (which keeps the appearance, organoleptic and nutritional characteristics of fresh fish intact) combined with a freezer that allows the blast chiller not to be occupied for many hours.

FOOD	indicative duration in months		
	-18°C	-25°C	-30°C
Vegetables	12	18	24
Fruit	12	18	24
Beef	9	12	18
Veal, lamb	6	12	18
Pig	4	12	15
Rabbits, poultry	4-6	-	-
Game	6-10	12	12
Lean fish	6-8	12	15
Fatty fish	3-4	7-8	8-9
Shellfish	3-4	12	17
Molluscs	2-3	10	12
Butter	8	12	15
Cheeses	4	6	6
Pre-cooked	2-4	6	6
Sweets	2-4	8	12

## CONTROL PANEL

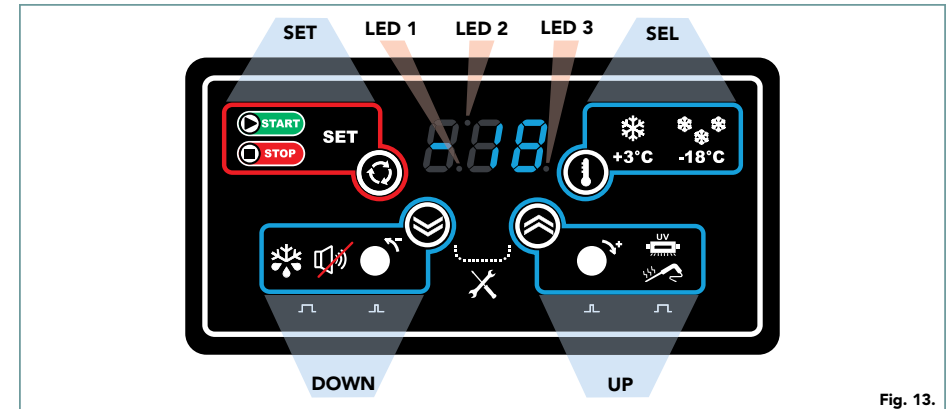

Fig. 13.

NAME	MODALITY	DESCRIPTION
SET	single press	- Starting a blast chilling cycle - Stopping a blast chilling cycle early - Confirming the value/choice made
SEL	single press	- Selection of positive (+ 3 °C) or negative (-18 °C) blast chilling
	continuous pressure	- Displays the time elapsed since the start of the blast chilling cycle if the blast chilling cycle is still in progress - Displays the duration of the previous blast chilling cycle if the preservation phase is in progress
DOWN	single press	- Slowly decrease a value - Silence the beep
	long press (4 seconds)	- Quickly decrease a value - Activate cold room defrost
UP	single press	- Slowly increase a value - Display the cell probe temperature during a running cycle
	long press (4 seconds)	- Quickly increase a value - Activate cell sterilization (only for pre-set devices) - Activate heated probe (only for pre-set devices)

NAME	DESCRIPTION
LED 1	LED with decimal point function for time indication (e.g., 4:30 = 4 hours and 30 minutes = 270 minutes)
LED 2	If on, negative chilling cycle in progress
LED 3	Fixed light: indicates the blast chilling cycle is in progress Floating light: indicates the preservation phase is in progress.

## USE

**!** Before use, read all safety warnings on the first pages of this manual. Your blast chiller allows you to perform positive (+3°C) or negative (-18°C) chilling cycles, ALWAYS automatically followed by a storage phase at 0°C (if the storage phase follows a positive chilling cycle) or at -25°C (if the storage phase follows a negative chilling cycle).

Type of felling	Temperature reached	Difference between MANUAL and AUTOMATIC cycle
positive reduction	+ 3 °C	Automatic: the cycle stops when the core probe detects that the core temperature of the food has reached +3°C.
		Manual: the cycle stops after a time set by the user has elapsed
negative reduction	- 18 °C	Automatic: the cycle stops when the core probe detects that the core temperature of the food has reached -18°C.
		Manual: the cycle stops after a time set by the user has elapsed

## PREPARATION

Before using the appliance for the first time, clean the inside of the compartment as explained in the relevant chapter. Place the foods to be blast chilled/frozen in the compartment, arranging them as explained previously (Fig. 14).



Fig. 14

## IGNITION

Power on the appliance (Fig. 15): the display performs a lamp test (all segments and dots flash for 5 seconds) and then goes into standby mode. When the appliance is subsequently turned on (for example, after a blackout), the blast chiller's status varies based on its status before the power outage:

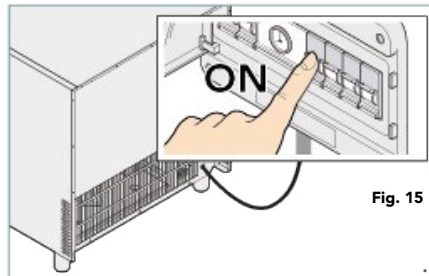

Fig. 15

State of the blast chiller BEFORE the power outage	State of shock upon restoration of electricity
blast chiller stopped	blast chiller stopped
blast chiller in operation (cycle in progress)	the interrupted chilling cycle restarts from zero

## STAND-BY FUNCTION

If no program is running, you can activate the stand-by mode (energy saving) by holding down

the **!** SEL button for approximately 4 seconds, until 3 dashes --- appear on the display (Fig. 16).



Fig. 16

## SELECTION AND START OF THE CHILLING CYCLE

### AUTOMATIC CYCLE (WITH NEEDLE PROBE)

The cycle stops automatically when the pin probe detects that the core temperature of the food has reached +3°C (if positive blast chilling has been selected) or -18°C (if negative blast chilling has been selected).

(1) Insert the core probe deeply into the largest piece of food.

(2) Press the **!** SEL button repeatedly until the display shows:

+3 (positive blast chilling)  
-18 (negative blast chilling).

(3) Wait 5 seconds or press the **!** SET button.

(4) Press the **!** SET button again to start the selected cycle: the temperature detected by the core probe appears on the display (in the example at right, +80°C).

During the chilling cycle, holding down the SEL button displays the time elapsed since the cycle started.

(5) When the probe detects that the core temperature of the food has reached +3°C or -18°C, the cycle stops automatically, the temperature detected by the core probe appears on the display and an acoustic signal starts (to stop it, press the **!** DOWN button).

If the value flashes, it means that the temperature of +3°C/-18°C has not been reached within the times set by the factory, for example due to overloading of the machine.

At the end of the blast chilling cycle, a preservation cycle begins automatically.

During this phase, the temperature detected by the cell probe is displayed on the display.

Type of felling	Storage cycle temperature
positive reduction	0 °C
negative reduction	-25 °C

**!** To end a blast chilling cycle early, press the **!** SET button. Press the button again to restart the cycle from where it was interrupted.

**!** At the end of a cycle, before starting the next one, the data for the last cycle performed appears on the display.

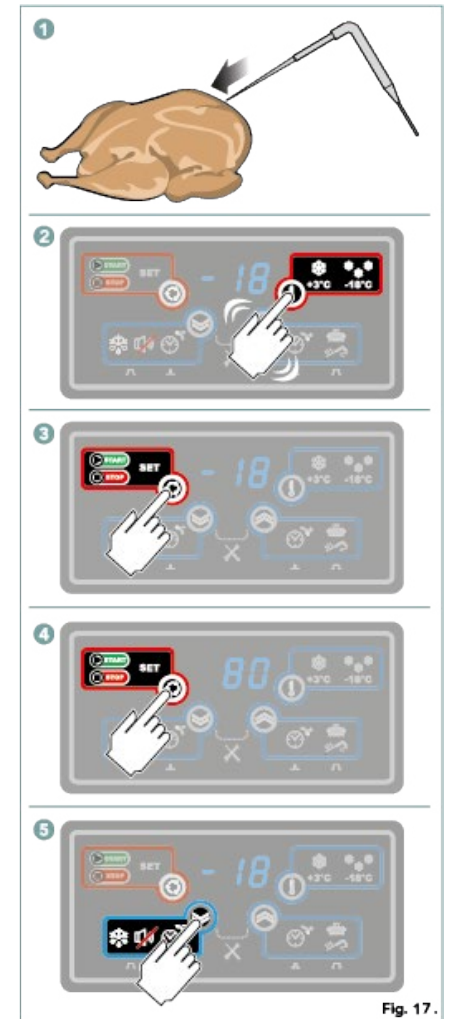



Fig. 17.



## MANUAL TIMED CYCLE

The cycle stops automatically after a time set by the user has elapsed.

(1) Press the  SEL button repeatedly until the display shows:

+3 (positive blast chilling)  
-18 (negative blast chilling)

(2) Wait 5 seconds or press the SET button.

(3) Press the  UP and  DOWN buttons until the desired blast chilling cycle duration is set (the default values displayed are: 90 min. positive blast chilling, 270 min. negative blast chilling).

The time setting is displayed in hours and minutes.  
Ex. 4:30 = 4 hours and 30 minutes = 270 minutes  
Ex. 1:20 = 1 hour and 20 minutes = 80 minutes



(4) Wait 5 seconds or press the  SET button.

(5) Press the  SET button again to start the selected cycle: the remaining cycle time appears on the display.

(6) When the time expires, the cycle stops automatically. The temperature detected by the cell probe appears on the display, and an acoustic signal sounds (to stop the signal, press the  DOWN button).

At the end of the blast chilling cycle, a preservation cycle starts automatically. During this phase, the temperature detected by the cell probe appears on the display.

Type of felling	Storage cycle temperature
positive reduction	0 °C
negative reduction	-25 °C

 To end a blast chilling cycle early, press the  SET button. Press the button again to restart the cycle from where it was interrupted.

 At the end of a cycle, before starting the next one, the data for the last cycle performed appears on the display.

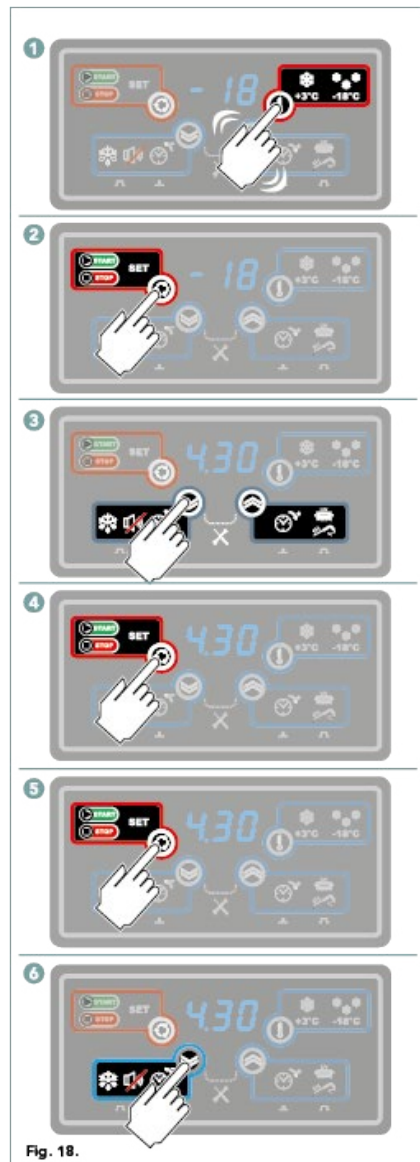



Fig. 18.

## SPECIAL FUNCTIONS

This appliance has a special function: manual defrosting.

At the end of the special function, a preservation phase automatically starts and an intermittent beep sounds

To silence the beep, press the  DOWN button.

### MANUAL DEFROSTING

Manual defrosting must be done with the door open to allow heat exchange.

To start it, press and hold the  DOWN button for 4 seconds until "dEF" appears on the display (Fig. 19).

The default time is 10 minutes (with the cabinet fan on) + 3 minutes of defrosting (with the cabinet fan off). Once defrosting is complete, remove the cap from the bottom of the cabinet to drain the water. If the appliance is not permanently connected to a drain, empty the 1/1 Gastronorm collection tray underneath.

 Do not use mechanical devices or other means to accelerate the defrosting process other than those recommended by the manufacturer.

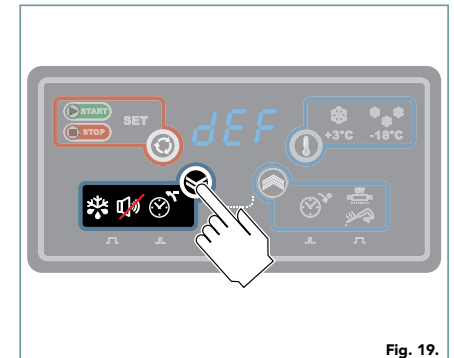

Fig. 19.

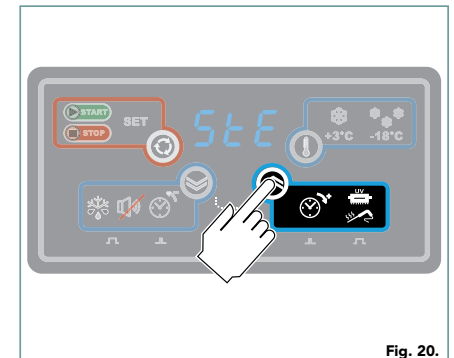

Fig. 20.

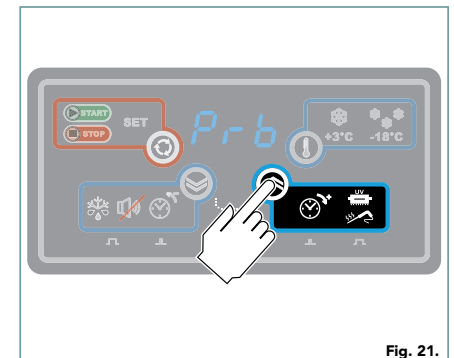

Fig. 21.

## MAINTENANCE

**!** Any ordinary maintenance operation must be carried out: after disconnecting the equipment from the power supply; after wearing adequate personal protective equipment (e.g. gloves, etc.).

**!** To clean any component or accessory DO NOT use: abrasive or powdered detergents; aggressive or corrosive detergents (e.g. hydrochloric/muriatic or sulfuric acid). Do not use these substances even to clean the floor under the appliance; abrasive or sharp tools (e.g. abrasive sponges, scrapers, steel brushes, etc.); jets of water, pressurized water or steam.

### CLEANING STEEL SURFACES

Use only a soft cloth soaked in a little soapy water. Rinse and dry thoroughly.

### CLEANING THE INSIDE OF THE CELL

To ensure hygiene and the quality of the processed food products, the cell must be cleaned after each use.

Use a soft cloth soaked in warm, soapy water, finishing with rinsing and drying.

For greater sanitization, spray the inside of the refrigerator with a sanitizing spray at least once a week. Use only products suitable for food contact surfaces. If using a food contact cleaner, follow the detergent manufacturer's instructions.

Always make sure that no product residue remains inside the cell as it could contaminate foods introduced subsequently.

Fig. 22. Fig. 23. Clean the internal fan grilles and the rear ventilation grille frequently with a soft-bristled brush or a vacuum cleaner.

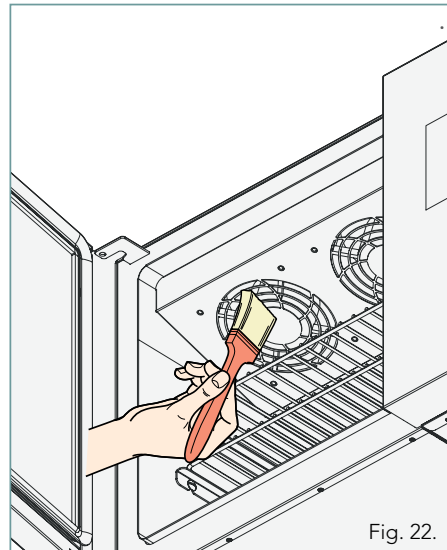

Fig. 22.

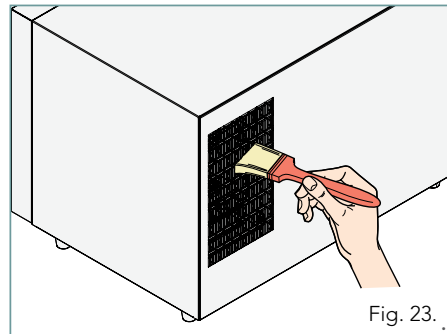

Fig. 23.

### CONTROL PANEL

Use a cloth lightly soaked in a neutral-based product and rinse. Avoid spraying too much product to avoid seepage that could damage the display.

### GASKET CLEANING

Periodically check the condition and tightness of the door seal; if it is damaged, contact the manufacturer for replacement.

Clean it with a cloth soaked in warm, soapy water. Finish by rinsing and drying.

## PERIODS OF INACTIVITY

During periods of inactivity, observe the following precautions: disconnect the equipment from the electrical power supply; carry out cleaning as indicated; keep the appliance door slightly open.

On first use:

thoroughly clean the equipment and accessories; reconnect the equipment to the power supply; inspect the equipment before reusing it; restart the appliance for at least 50 minutes without any food inside.

## END-OF-LIFE DISPOSAL

Pursuant to art. 14 of Legislative Decree 25 July 2005, n. 151 Implementation of Directives 2002/95/EC, 2002/96/EC and 2003/108/EC.

At the end of its useful life, the product must not be treated as other waste but must be disposed of separately. Please remember that abusive or incorrect disposal of the product will result in the application of the penalties provided for by the applicable laws. All equipment is made of recyclable metal materials (stainless steel, iron, aluminum, galvanized sheet metal, copper, etc.) in a percentage greater than 90% by weight: the user must take the equipment at the end of its life to appropriate separate collection centers for electronic and electrical waste, or return it to the retailer when purchasing a new equivalent type of equipment, on a one-to-one basis. Make the equipment unusable for disposal by removing the power cord and any compartment or cavity closures (if any) to prevent anyone from becoming trapped inside. For more information, contact your local waste disposal service.

## ASSISTANCE

In the event of a fault, disconnect the appliance from the power supply and look for a possible solution in the table alongside. If the solution is not listed, contact a technical assistance centre authorised by the Manufacturer, stating:

the date of purchase;

the equipment data can be found on the rating plate located under the equipment.

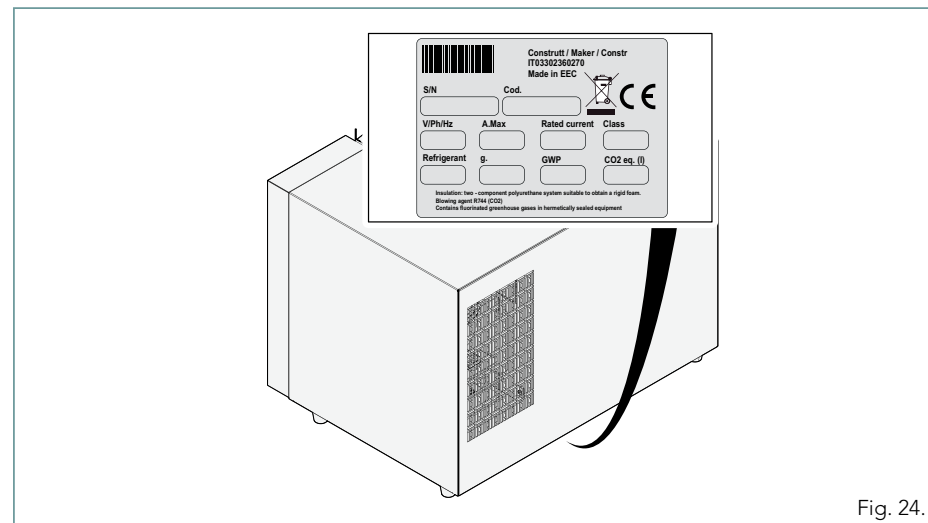
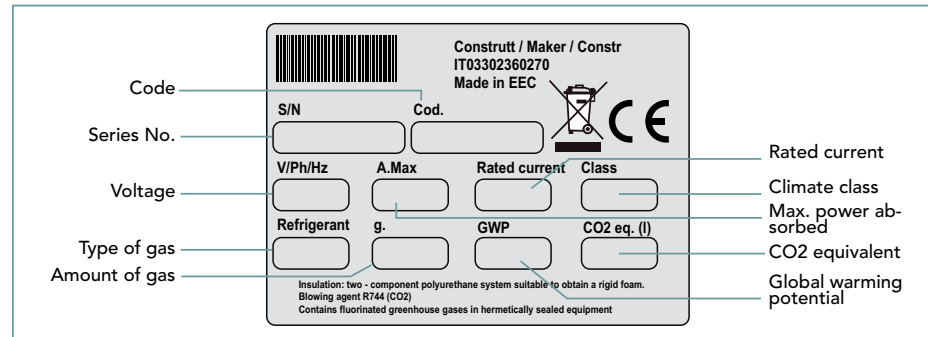

Fig. 24.

CAUSE	REMEDY
<b>THE DEVICE DOES NOT TURN ON</b>	
The plug is not inserted into the socket Interruption in the power supply	Restore the correct conditions of use. Please wait for the correct conditions of use to be restored.
Damaged component	Contact a service center for replacement
Condenser overload due to insufficient cooling	Clean the internal fan grilles and the rear ventilation grille with a soft-bristled brush or a vacuum cleaner. Move any objects covering the rear ventilation grille
<b>THE APPLIANCE DOES NOT CHILL OR FREEZE FOOD PROPERLY OR TAKES A LONG TIME TO DO SO</b>	
Manually set chilling times too short	Increase the chilling times
Pin probe inserted incorrectly (e.g. too shallow)	Insert the probe correctly
The appliance has been overloaded or loaded incorrectly	Follow the instructions and loading methods of the equipment
The door seal is damaged and does not close properly	Contact a service center for replacement
The internal fan grilles and the rear ventilation grille are blocked by dust or objects	Clean the internal fan grilles and the rear ventilation grille with a soft-bristled brush or a vacuum cleaner. Move any objects covering the rear ventilation grille
The ambient temperature is too high (permitted ranges: temperature between +16 and +32 °C and humidity not exceeding 60%)	Reduce the room temperature, move the machine to another room or move it away from hot appliances (e.g. fryers, ovens, etc.)
Lack of refrigerant gas.	Contact a service center for replacement
Faulty cell probe, needle or thermostat	Contact a service center for replacement
The control panel does not respond to commands for a prolonged period of time	Try unplugging the appliance for a few seconds and restarting the blast chiller

## REFRIGERANT GAS SAFETY DATA SHEET

### GAS WARNINGS

The equipment operates with propane R290, a high-purity HC hydrocarbon with low environmental impact and excellent thermodynamic properties.

The refrigerant circuit is hermetically sealed. The only possibility of leakage is the accidental breakage of a refrigerant circuit pipe during routine and/or extraordinary maintenance. In the event of accidental breakage, it is necessary to provide appropriate disposal and first aid facilities as indicated below.

### GAS CHARACTERISTICS

It does not damage the ozone layer (ODP = 0).  
Global warming potential (GWP) = 3  
Boiling point at 1,013 bar: -42°C | -43°F  
Glide (temperature slide) (°C): 0  
UN No.: 1978  
Security classification: A3.

Non-toxic but extremely flammable.

Hazard identification

Prolonged exposure through inhalation may cause anesthetic effects and cardiac arrhythmias. Sprayed or splashed product may cause frostbite to the eyes or skin.

The gas is highly flammable. Keep away from heat, hot surfaces, sparks, open flames, or other ignition sources. Do not smoke.

### FIRST AID MEASURES FOR INHALATION

Prolonged inhalation exposure may cause anesthetic effects and cardiac arrhythmias. Higher concentrations may cause asphyxiation due to the reduced oxygen content of the atmosphere.

### SKIN CONTACT

Splashes and spray can cause frostbite. Occasional contact is unlikely to be dangerous, but repeated or prolonged contact can cause removal of skin fat, resulting in dryness, cracking, and dermatitis.

### EYE CONTACT

Rinse immediately with clean water, holding the eyelids apart, for at least 15 minutes. Seek medical attention.

### INGESTION

Do not induce vomiting! If the victim is conscious, rinse their mouth with water and drink 200-300 ml of water. Seek immediate medical attention.

### FIRE PREVENTION MEASURES

Highly flammable. Incomplete thermal decomposition causes the release of highly toxic and corrosive vapors (carbon monoxide). In case of fire, use self-contained breathing apparatus and appropriate protective clothing. Do not use water. Have a CO<sub>2</sub> (carbon dioxide) fire extinguisher ready, and cool the engine compartment area as quickly as possible.

### EXTINGUISHING MEANS

Do not use water jets, but use extinguishing agents appropriate to the surrounding fire.

Accidental spills and disposal

In the event of accidental leaks of flammable gas from the machine's refrigeration circuit, do not attempt to stop it. Instead, unplug the power cord and ventilate and evacuate the area immediately, following the local safety plan. Do not touch or inhale the leaking gas.

Please note that the gas is highly flammable.

Then contact technical support to repair the machine.

Disposal of leaking gas must be carried out by authorized and qualified centers; if in doubt, contact your local authorities for additional information.

## RULES APPLIED

The rapid cooler complies with Directive 2014/30/EU on electromagnetic compatibility and meets the following standards:

IEC/EN 60335-1 ed. 5.2

IEC/EN 60335-2-24 ed. 7.2

IEC 60335-2-6 ed. 6.1

