

MOD : BSC5/75-20

Production code : BSC5/150-5



Stainless steel electronic scale

Installation and User Manual



MODEL : BSC5/150-5

EN

CONTENTS

Revision 1_revE. October 2024

1.0 INTRODUCTION	2
2.0 SPECIFICATIONS	3
3.0 INSTALLATION	4
3.1 UNPACKING	4
3.2 LOCATING	5
3.3 SETTING UP	6
3.3.1 SETTING UP THE BSC 3	6
3.3.2 SETTING UP THE BSC 5	7
4.0 KEYPAD	8
5.0 DISPLAY	8
6.0 SYMBOLS AND INDICATORS	8
7.0 BATTERY	9
8.0 BACKLIGHT	9
9.0 AUTO POWER OFF	9
10.0 OPERATIONS	10
10.1 SWITCHING ON THE SCALE	10
10.2 ZEROING	10
10.3 TARING	10
10.4 SELECTING THE UNIT	12
10.5 WEIGHING	12
11.0 RS-232 INTERFACE	12
12.0 CALIBRATION	14
13.0 PARAMETER SETTING	15
13.1 USER PARAMETERS	15
13.1.1 AUTO POWER OFF	16
13.1.2 SETTING OF BACKLIGHT	16
13.1.3 ENABLING OF UNITS	17
13.1.4 COMMUNICATION ADDRESS	17
13.1.5 SELECTION OF BAUD RATE	18
13.1.6 SELECTION OF BIT RATE AND PARITY	18
13.1.7 SELECTION OF TRANSMISSION MODE	19
13.1.8 SELECTION OF HOLD FUNCTION	19
13.1.9 SETTING OF HOLD TIME LIMIT	20
13.2 TECHNICAL PARAMETERS	21
13.2.1 FILTER	22
13.2.2 ZERO TRACKING	22
13.2.3 STABILIZATION RANGE	22
13.2.4 STABILIZATION TRACKING	23
13.3 FACTORY PARAMETERS	23
14.0 ERROR MESSAGES	24
15.0 SERVICE INFORMATION	25
16.0 WARRANTY INFORMATION	26

1.0 INTRODUCTION

The **BSC** range of Platform Scales has a stainless steel top pan on a steel frame and an indicator with a large backlit LCD. The water-resistant keyboard has 4 easy to use function keys: **[On/Off]**, **[Print/Hold]**, **[Unit]**, and **[Tare/Zero]**. All scales are supplied with the Power Supply module.

BSC3



300 x 300mm base
operates with 6 x AA size batteries.

BSC5



500 x 500mm base
with internal rechargeable batteries

2.0 SPECIFICATIONS

→ Model	BSC 3/15-5	BSC 3/35-10	BSC 5/75-20	BSC 5/150-5
Capacity x Readability d=e=	15kg / 5g	35kg / 10g	75kg / 20g	150kg / 50g
Repeatability	0.002kg	0.005kg	0.02kg	0.05kg
Linearity	0.004kg	0.01kg	0.04kg	0.1kg

→ Series	BSC 3	BSC 5
Platform size	300 x 300 mm	500 x 500 mm
Power Option		
Mains Power Adapter	12 VDC 800 mA (South Africa) 12 VDC 500 mA (Rest of World)	12 VDC 800 mA
6 x AA size batteries	✓	
Internal rechargeable battery (~ 60 hrs)		✓
Net weight	4 kg	8.9 kg
Indicator Dimensions (w x d x h)	220 x 95 x 43 mm	
Indicator Mounting	Cable	
Stabilization time	2 - 3 seconds	
Tare	Full range tare by subtraction	
Weighing units	kg, lb, oz, lb:oz	
Calibration	Automatic External - user selectable cal weight	
Interface	Bi-directional RS-232	
Protection Grade	IPX0	
Operating temperature	0°C to 40°C	
Humidity	10% ~ 80% RH non-condensing	
Display	25 mm Backlit LCD digits with weight legends for kg, lb, oz, lb:oz and low battery, stable, zero, net weight and Hold symbols	
Keypad	Mechanical switches under overlay	
Scale housing	Indicator: Aluminium Platform: Mild steel base and stainless steel pan	
Applications	Weighing, Dynamic / Animal weighing, Display Hold	

3.0 INSTALLATION

3.1 UNPACKING

The scales come as standard with-

BSC 3

- ✓ BSC3 Indicator with bracket and 2 screws
- ✓ The Platform
- ✓ Stainless Steel Pan
- ✓ Power supply Module
- ✓ An Instruction manual

BSC 5

- ✓ BSC 5 Indicator with bracket and 2 screws
 - ✓ The Platform
 - ✓ Stainless Steel Pan
 - ✓ Power supply Module
 - ✓ An Instruction manual
 - ✓ Internal rechargeable battery
-

3.2 LOCATING

- The scales should not be placed in a location that will reduce the accuracy.
- Avoid extremes of temperature. Do not place the scale in direct sunlight or near air conditioning vents.
- Avoid unsuitable surfaces. The table or floor should be rigid and free from vibration.
- Avoid unstable power sources. Do not use the scale near large users of electricity such as welding equipment or large motors.
- Do not place the scale near vibrating machinery.
- Protection Grade: IPX0
Avoid high humidity that might cause condensation. Avoid direct contact with water. Do not spray or immerse the scales in water.
- Avoid air movement such as from fans or opening doors. Do not place the scale near open windows or air-conditioning vents.
- Keep the scales clean. Do not stack material on the scales when they are not in use.

3.3 SETTING UP

3.3.1 SETTING UP THE BSC 3

1> Remove the parts from the packing carefully. Place the base on a rigid surface. Place the Stainless Steel pan on the base, if it not already assembled.

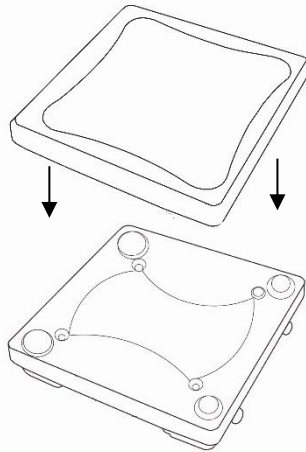

2> The indicator is separately packed and comes attached to a bracket with the help of two thumb screws.

Caution: Do not install the thumbscrews without the bracket being in place.

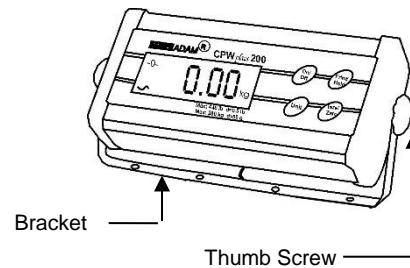

To adjust the angle of the indicator, use the two thumb screws on the side of the bracket that connects the indicator.

3> Where applicable connect the cable attached to the base to the connector at the rear of the indicator. Tighten the ferrule to secure the cable.

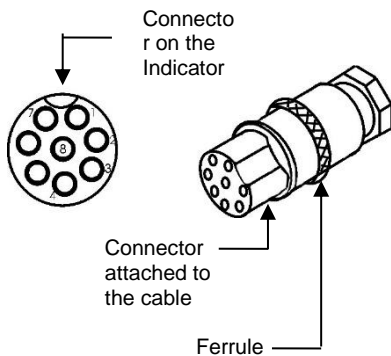

NOTE: When moving the scale, take care to prevent bending of the cable and connector too much as over a period of time this can weaken the wires in the connector and cause malfunction.

4> Power can be supplied using the mains power adapter or by fitting batteries inside the scale unit (6 x AA size).

Remove the cover from the battery compartment under the scale. Install six AA alkaline batteries as shown below.

Note: Rechargeable (1.2volt) batteries will not work, only alkaline batteries should be used.

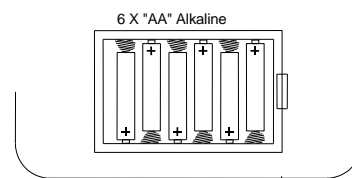

Note: The backlight should be set to OFF to prolong the life of the batteries. See section 13.1.2

MOUNTING THE INDICATOR- The indicator attached to the bracket can be mounted in the following 3 ways. To adjust the angle of the indicator, use the two thumb screws on the side of the bracket that connects the indicator.

1. **Place it on the work bench-** Simply place the indicator attached to the bracket on the work bench at an angle.
2. **Attach it to the base of the scale-** There are two thumb screws on the base (opposite to the Power input and RS-232 ports). Remove them from the base and use them to attach the bracket to the base.
3. **Mount it on the wall-** Use two suitable screws (not supplied) to fix the bracket to the wall.

3.3.2 SETTING UP THE BSC 5

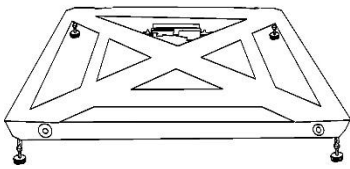
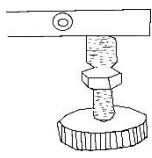
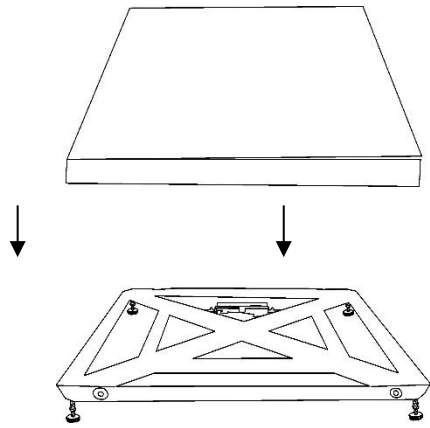
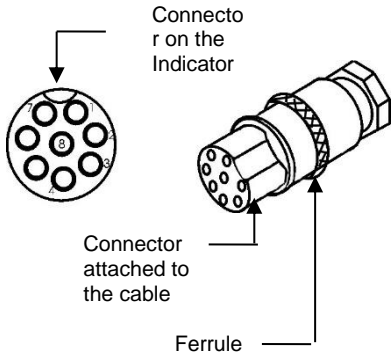
<p>1</p> <p>Remove the parts from the packing carefully. Place the base on a rigid floor.</p>  <p>Level the base using the four adjustable feet.</p> <p>Adjustable feet → </p>	<p>2</p> <p>Place the Stainless Steel pan on the base, if it not already assembled.</p> 
<p>3</p> <p>The indicator is separately packed and comes attached to a bracket with the help of two thumb screws. As shown above.</p> <p>To adjust the angle of the indicator, use the two thumb screws on the side of the bracket that connects the indicator. The Indicator can be placed on any flat surface or mounted on the wall.</p>	<p>4</p> <p>Connect the cable attached to the base to the connector at the rear of the indicator. Tighten the ferrule to secure the cable.</p>  <p>NOTE: When moving the scale, take care to prevent bending of the cable and connector too much as over a period of time this can weaken the wires in the connector and cause malfunction.</p>

NOTE: The BSC 5 have a rechargeable battery in the base unit. The indicator must be connected to the base to charge the battery. To re-charge the internal battery, connect the power supply module to the rear of the indicator and apply power.

Before operating parts marked with a  symbol please read this instruction manual and operate with caution to avoid hazard.

4.0 KEYPAD



[On / Off]	Turns the scale on or off only
[Print/Hold]	Sends data via RS-232 and combines with Hold functions, if enabled
[Unit]	Selects kilograms, pounds, ounces or pounds-ounces
[Tare/Zero]	Sets the display to true zero or net zero by storing the current weight in the tare memory

5.0 DISPLAY



6.0 SYMBOLS AND INDICATORS

Symbol	Description
→0←	Scale is in the zero position
S	Weighing result is stable
kg , lb, oz or lb-oz	Active weighing unit
🔋	Battery is weak
:	When weighing in pounds:ounces
Net	Net weight is being displayed
Hold	Display is held as per the Hold parameter setting (See section 9.8 & 9.9)

7.0 BATTERY

- BSC 3 unit can be operated from 6x AA batteries, if desired.
- BSC 5 scales have an internal rechargeable battery. When the battery needs charging a symbol on the display will turn on. The battery should be charged when the symbol is on.
- To charge the battery, connect the power supply module to the rear of the indicator and apply power. The scale need not be turned on. **The indicator must be attached to the base for the batteries to charge.**
- The battery should be charged for 12 hours for full capacity. The battery life is approximately 60 hours.
- Internal rechargeable batteries can be changed, but please first ask for technical support from your dealer or the manufacturer. Replacement batteries should be type BT-6M1.3AC (6V1.3AH) or direct equivalent.

NOTE: When you turn off the scale by pressing the ON/OFF key, the power is not completely isolated. You should disconnect the power supply if it is not going to be used for an extended period.

8.0 BACKLIGHT

The backlight for the LCD can be set by the user to always off, always on or automatic (on only when the scale is in use or a key is pressed). See setting of the parameter in section 13.1.2.

The backlight should be set to OFF when batteries are used to prolong the battery life.

9.0 AUTO POWER OFF

The auto power off can be set by the user to disable the feature or to a pre-set time interval. See setting of the parameter in section 13.1.1.

10.0 OPERATIONS

10.1 SWITCHING ON THE SCALE

- To switch on the scale, press the **[On/Off]** key.
- The display will show the software revision number and then flash all the digits and symbols before counting down to zero. This ensures all LCD segments are working. The last active weighing unit will be displayed.



- The scale will turn off automatically to conserve battery life if the automatic turn off parameter is set (see section 13.1.1). To turn off the scale press the **[On/Off]** key.
- A battery symbol will be on when the internal battery needs to be re-charged. Connect the power supply module to the rear of the indicator and switch on the mains.

10.2 ZEROING

- The ZERO and TARE function is combined into one key **[Tare/Zero]**.
- You can press the **[Tare/Zero]** key at any time to set a new zero point. Re-zeroing the scale may be necessary if a small amount of weight is still shown when the platform is empty.
- If the scale is less than 2% of the maximum capacity, pressing **[Tare/Zero]** will zero the scale. However, if the weight on the scale is more than 2%, pressing **[Tare/Zero]** will tare the scale. See the next section on taring the scale.
- The scale has an automatic zero tracking function to account for shifting of the zero point due to the environment change or accumulation of dust on the platform.

10.3 TARING

- Zero the scale by pressing the **[Tare/ Zero]** key if necessary.

The zero indicator will be on.



- Place a container on the platform, a value for its weight will be displayed.



- Press the **[Tare/Zero]** key to tare the scale. The weight that was displayed is stored as the tare value. This value is subtracted from the display, leaving zero on the display. The indicator "**Net**" will be on.



- As a product is added to the container, only the weight of the product will be shown. The scale could be tared a second time if another type of product was to be added to the first one. Again only the weight of the product that is added after taring will be displayed.
- When the container is removed a negative value will be shown. If the scale was tared just before removing the container, this value is the gross weight of the container plus all products. The zero indicator will also be on because the platform is back to the same condition as it was when the **[Tare/Zero]** key was pressed last.



Note: If the capacity of the scale is 6000g and a container weighing 2450g is used and tared, the scale can then be used to weigh the material of up to 3550g.

10.4 SELECTING THE UNIT

To select the weighing unit press the **[Unit]** key to move from one unit to another. The weighing unit must be enabled by the users beforehand (see section 13.1.3). If a unit is disabled it cannot be selected by using the **[Unit]** key.

10.5 WEIGHING

- When the scale is at zero, place an item to be weighed on the platform. The display will show the weight in the unit selected previously. The weighing result can be viewed in other enabled units using the **[Unit]** key.
- If a container is used, this can be tared as described in 10.3. The scale then shows the net weight of the material added.

11.0 RS-232 INTERFACE

The BSC scales come with a bi-directional RS-232 interface.

Interface parameters are:

RS-232 output of weighing data
ASCII code
Selectable Baud
Selectable data bits
Selectable Parity

Connection details are:

Connector: 9 pin D-subminiature socket
Pin 3 Output
Pin 2 Input
Pin 5 Signal Ground

Normal OutputU: (See section 13.1.7)

```
add: A
G/W: + 2.00 kg      G/W is Gross Weight
<cr><lf>
<cr><lf>
<cr><lf>
add: A
N/W: + 1.00 kg      N/W is Net weight
<cr><lf>
<cr><lf>
<cr><lf>
```

Continuous OutputU: (See section 13.1.7)

```
ASNG/W + 0.00 xx      A is communication address set by the user,
ASNG/W + 0.51 xx      S stands for stable, N for no error G/W for
ASNG/W + 2.99 xx      gross weight, xx for the chosen unit
<cr><lf>
```

The scale can be controlled by a computer using the following commands. The commands must be sent in upper case letters, i.e. “**T**” and not “**t**”. The input and output formats are as given below.

Input commands format:

Z <cr> <lf>	Tares the scale to display the net weight- same as pressing [Tare/Zero]
H <cr> <lf>	Sets the scale to hold if the hold function is enabled. Same as pressing the [Hold] key
N <cr> <lf>	Sends the net weight to the RS-232 interface.
G <cr> <lf>	Sends the gross weight to the RS-232 interface.
T <cr> <lf>	Sends the tare weight to the RS-232 interface.

Output format:

G + 2.00 kg <cr><lf> N + 1.00 kg <cr><lf>
--

12.0 CALIBRATION

- Occasionally the scale should be verified whether it is weighing correctly by measuring to a known mass.
- Zero the scale. Place the mass on the centre of the platform and note the reading. Calibrate the scale, if necessary.

NOTE: Before calibrating your should make sure you have the correct weights. The weights should be known to an accuracy that is appropriate for the balance being calibrated, for example, OIML Class M1 type or ASTM E617 Class 4. If you do not have the correct weights do not attempt calibration.

PROCEDURE

- While in the normal weighing mode, press and hold the **[Tare/Zero]** key for 4 seconds.
- The display will show “**CAL**” along with the last selected unit. The unit can be changed by using the **[Unit]** key to calibrate in kg or lb.



A digital scale display showing the text "CAL" in a large, bold, monospace font on the left, and the unit "kg" in a smaller font on the right.

- Press the **[Print/Hold]** key. The display will show “**L XX**” where **XX** is the Calibration weight which is user-selectable.



A digital scale display showing the text "L" in a large, bold, monospace font on the left, "25" in a large, bold, monospace font in the middle, and "kg" in a smaller font on the right.

- Use the **[Tare/Zero]** key to change the flashing digit and the **[Print/Hold]** key to move to the next digit.
- Press the **[Unit]** key to confirm the calibration weight. The digit stops flashing.

Note: If the selected mass is less than 10% of the capacity of the scale, an error message “**CALEr**” will be displayed and the scale will return to zero. Repeat the process correctly.



A digital scale display showing the text "CALEr" in a large, bold, monospace font on the left, and the unit "kg" in a smaller font on the right. The 'r' is smaller than the other characters.





- Place the correct calibration mass as selected by the user at the centre of the pan.
- Press the **[Unit]**. The display will return to weighing mode.

Note: If the mass loaded is more than $\pm 20\%$ of the factory calibration reference then an error message “**CALEr**” will be displayed and the scale will return to weighing without calibration being saved. Repeat the process correctly.

- Remove the weight.
- Verify the scale is calibrated correctly. Repeat the process, if necessary.

13.0 PARAMETER SETTING

13.1 USER PARAMETERS

The scale can be set as desired by the user to control the weighing operation.

- Switch off the scale.
- Hold the **[Tare/Zero]** key and then press the **[On/Off]** key momentarily. Release the **[Tare/Zero]** key. The display shows the first parameter - auto power off.
- To exit the parameter setting at any time, press the **[Print/Hold]** key.
- To scroll through the user parameters, press the **[Unit]** key (which will advance to the next parameter).
- To return to normal weighing, turn the scale off and back to on again or press the **[Print/Hold]** key.

13.1.1 AUTO POWER OFF

- The first parameter is to set the auto power off function. The display will show **Pr off** (DEFAULT SET).
- Press **[Tare/Zero]** to toggle between **Pr on** and **Pr off**.

Pr on

Enables the Auto Power Off function. The power will be turned off after 2 minutes if a key has not been pressed for 2 minutes and the scale is at zero. If there is any weight on the scale or a key is pressed, the scale will continue to work.

Pr off

Disables the Auto Power Off function. The scale will not automatically turn off.

- Press the **[Unit]** key to confirm the selection and move to the next parameter.

13.1.2 SETTING OF BACKLIGHT

- The second parameter to set the backlight function. Display will show **bl 3** (DEFAULT SET).
- Press the **[Tare/Zero]** key to change the settings

bl 1

Off- backlight is switched off
The backlight should be set to OFF when batteries are used to prolong the battery life.
On- backlight is set to on always

bl 2

bl 3

Automatic- backlight will be off unless a weight is placed on the pan. When the weight is removed it will stay on for 10 seconds after the scale returns to zero.

- Press the **[Unit]** key to confirm the selection and move to the next parameter.

13.1.3 ENABLING OF UNITS

- The third parameter is to enable or disable the weighing units so that the user can select the enabled units during the weighing operation. Display will show “**on kg**” (DEFAULT SET)
- Use [**Tare/Zero**] to toggle between “**on**” and “**off**”.



Enables the unit



Disables the unit

- Press the [**Unit**] key to confirm the selection and move to the next unit which is “lb”.
- After all units are set, press the [**Unit**] key to move to the next parameter.

13.1.4 COMMUNICATION ADDRESS

- The fourth parameter is for setting the ID for the RS-232 results output. Display will show “**Add 0**” (DEFAULT SET)



- This parameter sets the communication address which is sent via RS-232 as an ID code. There are 26 options to select from “**Add 0**” to “**Add 25**”. Set “**Add 0**” for no address. The numbers relate to alphabets for example 1=A, 2=B to 25=Y
- Use the [**Tare/Zero**] key to scroll through the options.
- Press the [**Unit**] key to confirm the selection and move to the next parameter.

13.1.5 SELECTION OF BAUD RATE

- The fifth parameter is to select the baud rate per second which is the speed of sending data to RS-232 interface. Display will show “**b 9600**” (DEFAULT SET)
- Use the [**Tare/Zero**] key to scroll through the options.
- There are three options-

b 2400

b 4800

b 9600

- Press the [**Unit**] key to confirm the selection and move to the next parameter.

13.1.6 SELECTION OF BIT RATE AND PARITY

- The sixth parameter is to select the bit rate and parity used for sending data to RS-232 interface. Display will show “**PAR 1**” (DEFAULT SET)

PAR 1

8 bits no parity

PAR 2

7 bits even parity

PAR 3

7 bits odd parity

- Use the [**Tare/Zero**] key to scroll through the options.
- Press the [**Unit**] key to confirm the selection and move to the next parameter.

13.1.7 SELECTION OF TRANSMISSION MODE

- The seventh parameter is to select the transmission mode. Display will show “**trn 1**” (DEFAULT SET). See the HOLD AND PRINTING TABLE in section 13.1.9.

trn 1

No data output

trn 2

Continuous data output

trn 3

Normal output when the **[Print/Hold]** key is pressed

- Use the **[Tare/Zero]** key to scroll through the options.
- Press the **[Unit]** key to confirm the selection and move to the next parameter.

13.1.8 SELECTION OF HOLD FUNCTION

- The eighth parameter is to set the Hold function. Display will show “**Hod 1**” (DEFAULT SET). See the HOLD AND PRINTING TABLE in section 13.1.9.

Hod 1

No hold function

Hod 2

Automatic hold function

Hod 3

Manual hold function

- Use the **[Tare/Zero]** key to scroll through the options.
- If selection of “**Hod 2**” or “**Hod 3**” is made then it will lead to SETTING OF HOLD TIME LIMIT (see section 13.1.9). The display will show “**Hold**” above the weight during operation.

- If “**Hod 1**” is selected, pressing the **[Unit]** key will take you back to the first parameter on Auto Power Off.
- If you want to return to weighing, press the **[Print/Hold]** key.

13.1.9 SETTING OF HOLD TIME LIMIT

- This parameter is to set the time limit by which the display is held after the hold function is used. It is applicable if the hold function is set to “**Hod 2**” or “**Hod 3**”.
- Use the **[Tare/Zero]** key to scroll through the options.
- The options are-

HE, 0

Holds the display for an infinite time limit

HE, 1

Holds the display for 15 (1 x 15) seconds

HE, 2

Holds the display for 30 (2 x 15) seconds

HE, 3

Holds the display for 45 (3 x 15) seconds

HE, 4

Holds the display for 60 (4 x 15) seconds

- Press the **[Unit]** key to confirm the selection and move back to the first parameter or press **[Print/Hold]** to exit the parameter setting.

HOLD AND PRINTING TABLE

	trn 1	trn 2	trn 3
Hod 1	RS-232 is off. Hold is off. [Print/hold] key has no function.	Prints continuously. Hold is off. [Print/hold] key has no function.	RS-232 prints when [Print/Hold] is pressed. Hold function is disabled.
Hod 2	RS-232 is off. Hold occurs automatically when the weight is stable. Hold is released if [Print/Hold] is pressed or time expires as per Hti setting.	Print continuously. Hold occurs automatically when the weight is stable. Hold is released if [Print/Hold] is pressed or time expires as per Hti setting.	RS-232 prints and hold occurs automatically when the weight is stable. [Print/Hold] key is pressed print will occur again. Hold function is released if the key is pressed again or time expires as per Hti setting.
Hod 3	RS-232 is off Hold occurs when the [Print/Hold] key is pressed. Hold is released if [Print/Hold] is pressed again or time expires as per Hti setting.	Print continuously. Hold occurs when the [Print/Hold] key is pressed. Hold is released if [Print/Hold] is pressed again or time expires as per Hti setting.	RS-232 prints and the hold occurs when [Print/Hold] is pressed. If [Print/Hold] is pressed a second time print will occur again. Hold is released if [Print/Hold] is pressed again or time expires as per Hti setting.

13.2 TECHNICAL PARAMETERS

The technical parameters allow adjusting of the scale for accuracy and speed.

- Switch off the scale.
- Hold the **[Unit]** key and then press **[On/Off]** momentarily. Release the **[Unit]** key. The display shows the first technical parameter to set the filter “**Fi x**”.
- To exit the parameter setting at any time, press the **[Print/Hold]** key.
- To scroll through the technical parameters, press the **[Unit]** key (which will advance to the next parameter).
- To return to normal weighing, turn the scale off and back to on again or press the **[Print/Hold]** key.

13.2.1 FILTER

This parameter is for setting the speed of the display filter. For poor environments the filter should be set at its slowest to minimise external influences on the scale. For weighing small samples or gradual filling, the filter should be set at a faster setting.

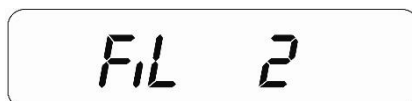
A digital display showing the text "FIL 2" in a monospaced font. The text is centered within a rounded rectangular border.

- Press [**Tare/Zero**] to scroll through the options. The display will show "**Fi 1**" to "**Fi 3**". If it is set to "**Fi 1**" then the display is at its slowest setting and at "**Fi 3**" the display is in its fastest setting.
- Press [**Unit**] to confirm the selection and move to the next parameter.

13.2.2 ZERO TRACKING

This parameter is for setting the range of the zero tracking. Zero tracking will aid the scale to hold or return to zero and should be increased if large weights are left on the scale or temperature is not consistent.

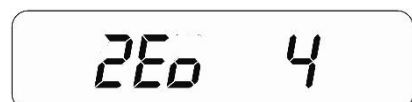
A digital display showing the text "ZEO 4" in a monospaced font. The text is centered within a rounded rectangular border.

- Press [**Tare/Zero**] to scroll through the settings. The display will show "**ZEO 1**" to "**ZEO 8**". If it is set to "**ZEO 1**" the zero tracking is at its smallest range and "**ZEO 8**" the highest.
- Press [**Unit**] to confirm the selection and move to the next parameter.

13.2.3 STABILIZATION RANGE

This parameter is for setting the range of the stability indicator. This is used to determine when the scale will print automatically as well as indicate that the weight is stable.

A digital display showing the text "SLR 5" in a monospaced font. The text is centered within a rounded rectangular border.

- Press [**Tare/Zero**] to scroll through the settings. The display will show “**StA 1**” to “**StA 8**”. If it is set to “**StA 8**” then the stability is at its fastest and “**StA 1**” the slowest.
- Press [**Unit**] to confirm the selection and move to the next parameter.

13.2.4 STABILIZATION TRACKING

This parameter is for setting the size of the tracking range to indicate the stability. This is used to stable the scale once a weighing result is achieved.



- Press [**Tare/Zero**] to scroll through the settings. The display will show “**Str 1**” to “**Str 5**”. If it is set to “**Str 1**” then the stability range is at its smallest and “**Str 5**” the highest.
- When the desired value is displayed, press the [**Print/Hold**] key to select the value and exit the Technical Parameters. The display will count down to zero and the scale will return to normal weighing.
- If [**Unit**] is pressed instead of the [**Print/Hold**] key, the display will ask for Pin for entering into the Factory Parameters. Switch off the scale.
- Switch on the scale to start the operation.



13.3 FACTORY PARAMETERS

If after the last Technical Parameter [**Unit**] key is pressed, the scale will advance to the Factory Parameter section. This section contains critical calibration reference information and is protected by a Pin Code which can only be accessed by a qualified technician. To exit, the user must switch off the scale when the display shows “**Pi**”.



14.0 ERROR MESSAGES

During the initial power-on testing or during the operation the scale may show an error message. The error messages are described below.

ERROR CODE	DESCRIPTION	POSSIBLE CAUSES
	A continuous beep is heard.	Weight on the pan exceeds the capacity of the scale. Remove the weight from the pan.
	If the selected mass is less than 10% or more than 20% of the capacity of the scale, an error message " CALEr " will be displayed and the scale will return to zero.	Incorrect calibration mass. Repeat the process correctly.

If an error message is shown, repeat the procedure that caused the message such as turning the scale on, calibration or any other functions. If the error message is still shown, contact your supplier for further support.

15.0 SERVICE INFORMATION

This manual covers the details of operation. If you have a problem with the scale that is not directly addressed by this manual then contact your supplier for assistance. In order to provide further assistance, the supplier will need the following information which should be kept ready:

A. Details of your company

- Name of your company:
- Contact person's name:
- Contact telephone, e-mail, fax or any other methods:

B. Details of the unit purchased
(This part of information should always be available for any future correspondence. We suggest you to fill in this form as soon as the unit is received and keep a print-out in your record for ready reference.)

Model name of the scale:	BSC.....
Serial number of the unit:	
Software revision number (Displayed when power is first turned on):	
Date of Purchase:	
Name of the supplier and place:	

C. Brief description of the problem

Include any recent history of the unit. For example:

- Has it been working since it's delivered
- Has it been in contact with water
- Damaged from a fire
- Electrical Storms in the area
- Dropped on the floor, etc.

16.0 WARRANTY INFORMATION

Limited Warranty (Parts and Labour) for the components failed due to defects in materials or workmanship. Warranty starts from the date of delivery.

During the warranty period, should any repairs be necessary, the purchaser must inform its supplier. The company or its authorised Technician reserves the right to repair or replace the components at any of its workshops depending on the severity of the problems. However, any freight involved in sending the faulty units or parts to the service centre should be borne by the purchaser.

The warranty will cease to operate if the equipment is not returned in the original packaging and with correct documentation for a claim to be processed. All claims are at the sole discretion of Supplier.

This warranty does not cover equipment where defects or poor performance is due to misuse, accidental damage, exposure to radioactive or corrosive materials, negligence, faulty installation, unauthorised modifications or attempted repair or failure to observe the requirements and recommendations as given in this User Manual.

Repairs carried out under the warranty does not extend the warranty period. Components removed during the warranty repairs become the company property.

The statutory right of the purchaser is not affected by this warranty. The terms of this warranty is governed by the UK law. For complete details on Warranty Information, see the terms and conditions of sale available on our web-site.

WEEE 2012/19/EU

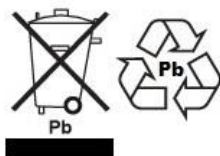

This device may not be disposed of in domestic waste. This also applies to countries outside the EU, per their specific requirements. Disposal of batteries (if fitted) must conform to local laws and restrictions.

Cet appareil ne peut être éliminé avec les déchets ménagers. L'élimination de la batterie doit être effectuée conformément aux lois et restrictions locales.

Dieses Gerät nicht mit dem Hausmüll entsorgt.

Dispositivo no puede ser desechado junto con los residuos domésticos

Dispositivo non può essere smaltito nei rifiuti domestici.

FCC / IC CLASS A DIGITAL DEVICE EMC VERIFICATION STATEMENT

NOTE: This equipment has been tested and found to comply with the limits for a Class A digital device, pursuant to Part 15 of the FCC rules and Canadian ICES-003/NMB-003 regulation. These limits are designed to provide reasonable protection against harmful interference when the equipment is operated in a commercial environment. This equipment generates, uses and can radiate radio frequency energy and, if not installed and used in accordance with the instruction manual, may cause harmful interference to radio communications. Operation of this equipment in a residential area is likely to cause harmful interference in which case the user will be required to correct the interference at his own expense.



Products have been tested with, and are always supplied with mains power adaptors which meet all legal requirements for the intended country or region of operation, including adaptor electrical safety, interference and energy efficiency. As we often update adaptor products to meet changing legislation it is not possible to refer to the exact model in this manual. Please contact us if you need specifications or safety information for your particular item. Do not attempt to connect or use an adaptor not supplied by us.