



MOD : DH80B/T2V

Production code : TS60D

09/2025

7.10 WIRING DIAGRAM SINGLE-PHASE TS5-8

(SCHEMA ELETTRICO IMPIANTO MONOFASE)

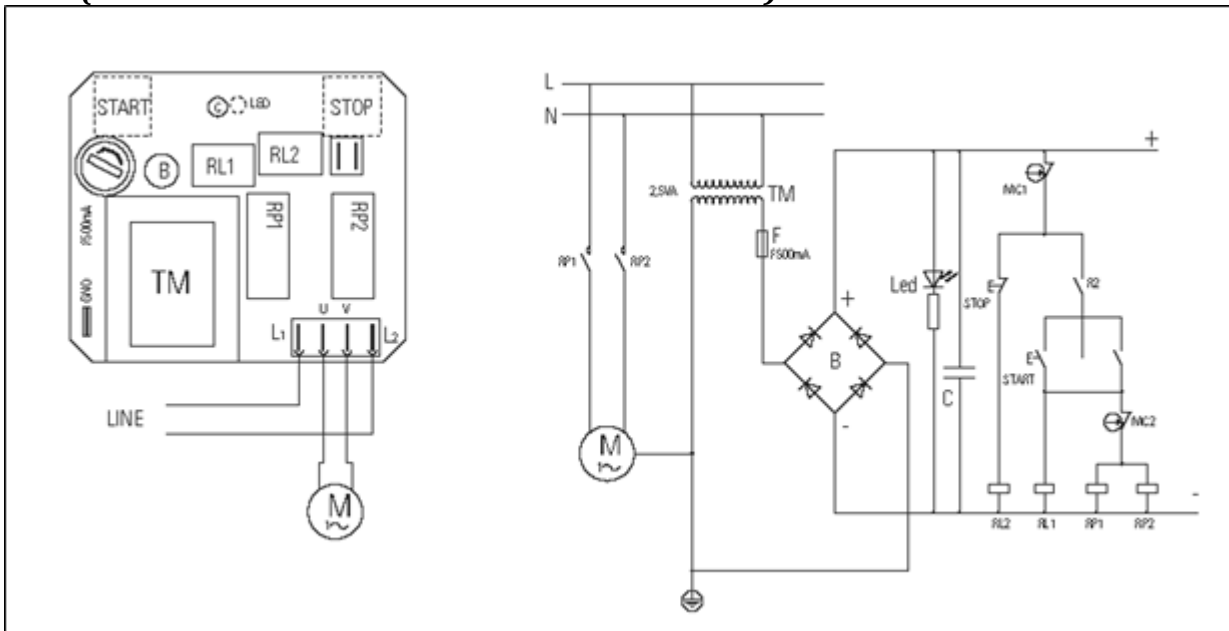

7.11 WIRING DIAGRAM THREE-PHASE TS5-8

(SCHEMA ELETTRICO IMPIANTO TRIFASE)

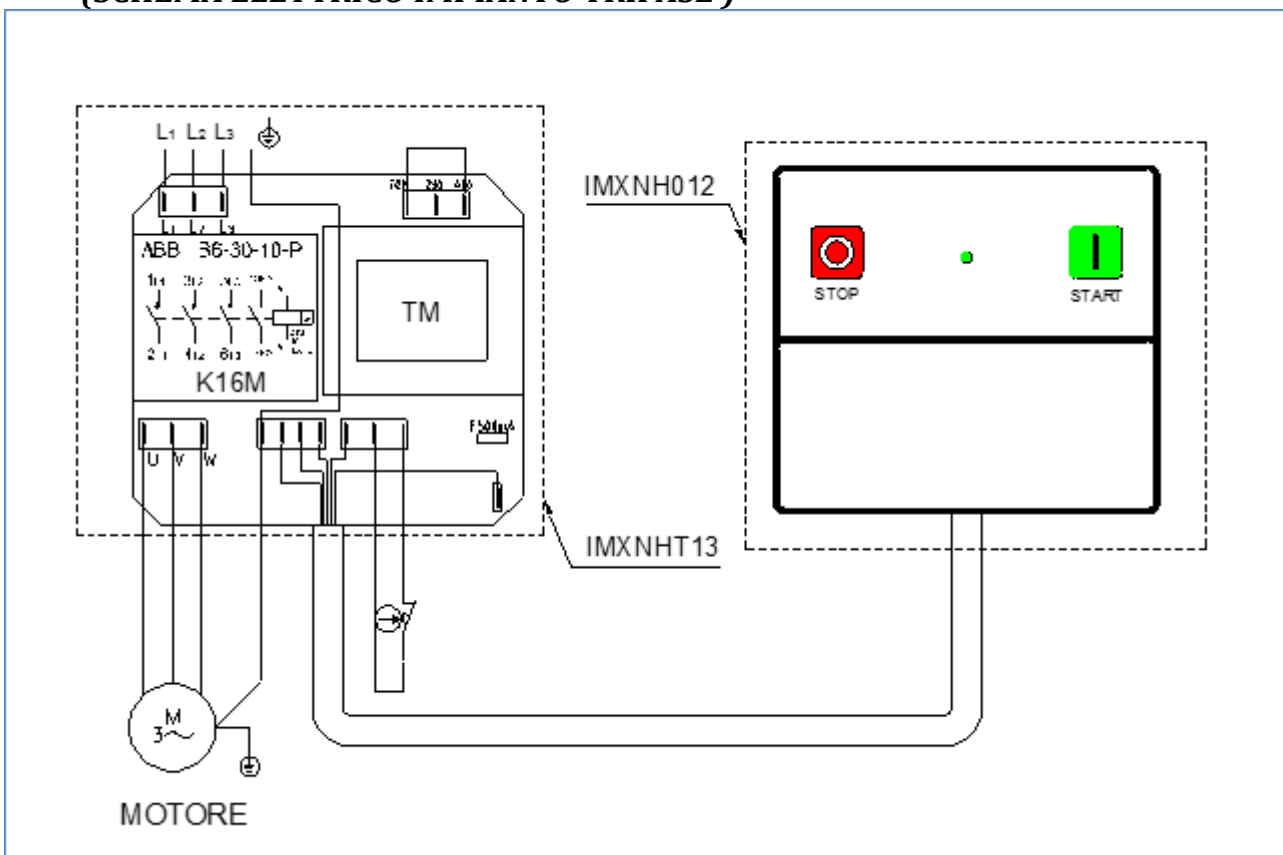

7.12 WIRING DIAGRAM THREE-PHASE – 2 SPEED -TS5-8

(SCHEMA ELETTRICO IMPIANTO TRIFASE – 2 VELOCITA')

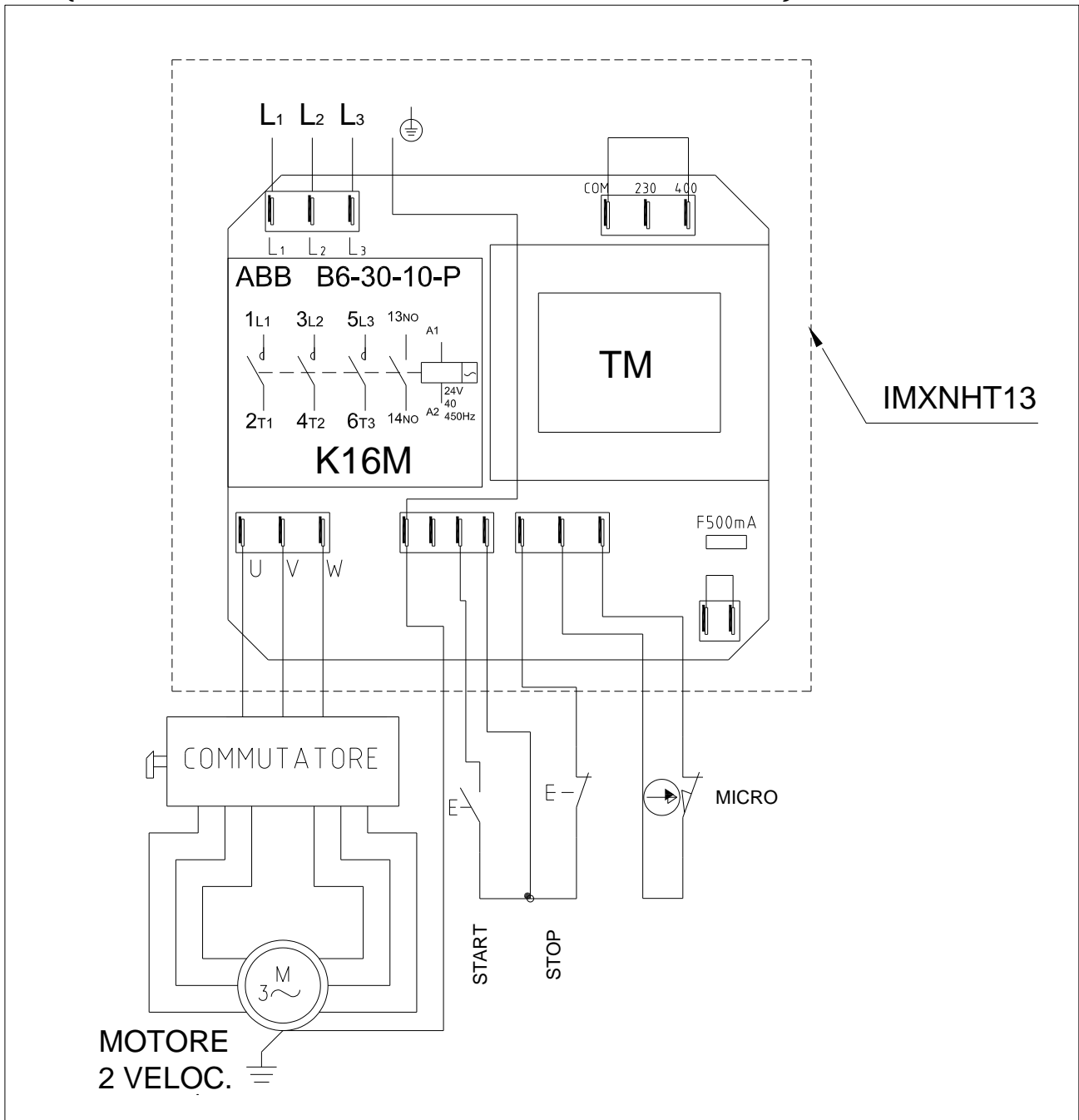

7.13 WIRING DIAGRAM SINGLE-PHASE TS/TSA12-18-38-44-60

(SCHEMA ELETTRICO IMPIANTO MONOFASE)

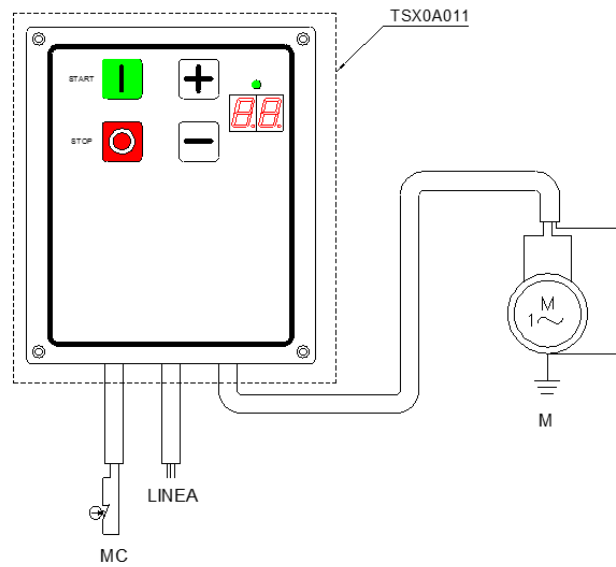

DETAILS OF CONNECTIONS OF ELECTRICAL BOARD OF SINGLE-PHASE ELECTRIC SYSTEM

(DETTAGLI DEI COLLEGAMENTI ALLA SCHEDA DIGITALE IMPIANTO MONOFASE)

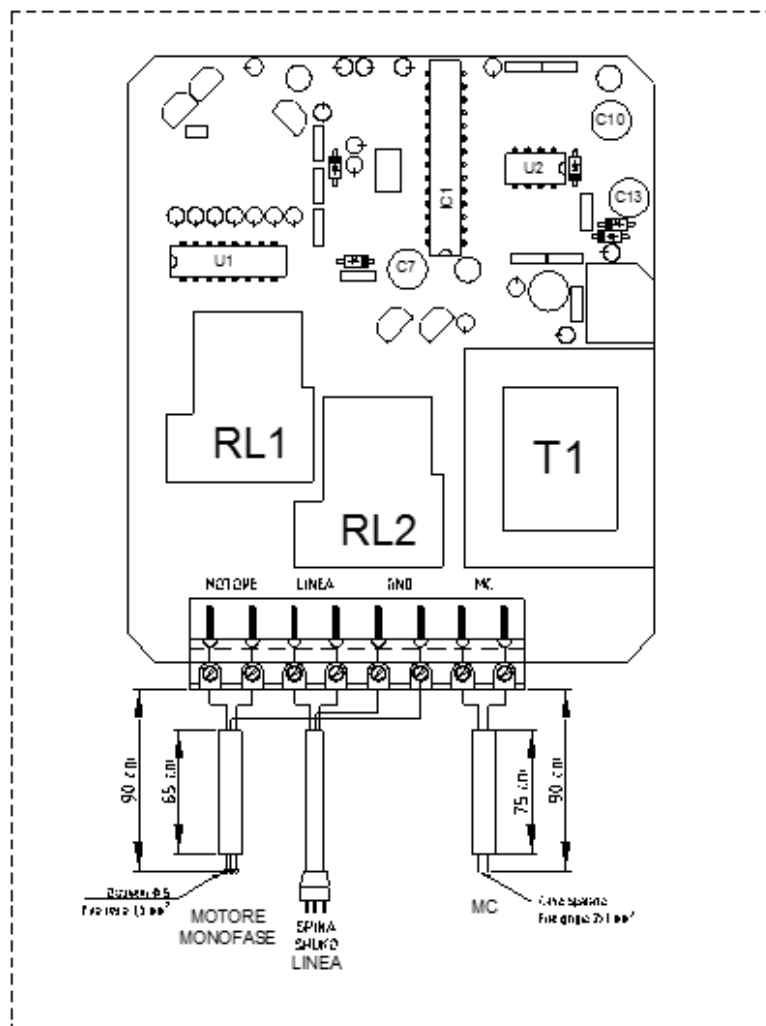

7.14 WIRING DIAGRAM THREE-PHASE TS/TSA12-18-38-44-60

(SCHEMA ELETTRICO IMPIANTO TRIFASE)

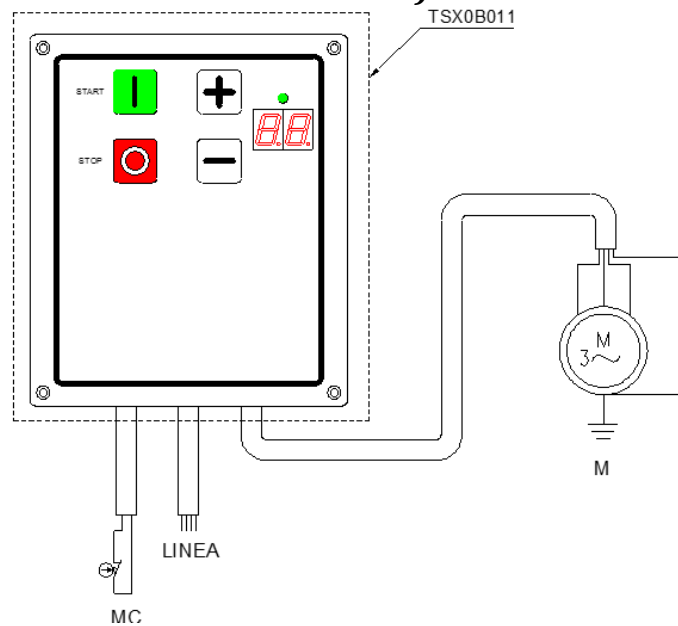

DETAILS OF CONNECTIONS TO ELECTRICAL BOARD OF THREE-PHASE ELECTRIC SYSTEM
(DETTAGLI DEI COLLEGAMENTI ALLA SCHEDA DIGITALE IMPIANTO TRIFASE)

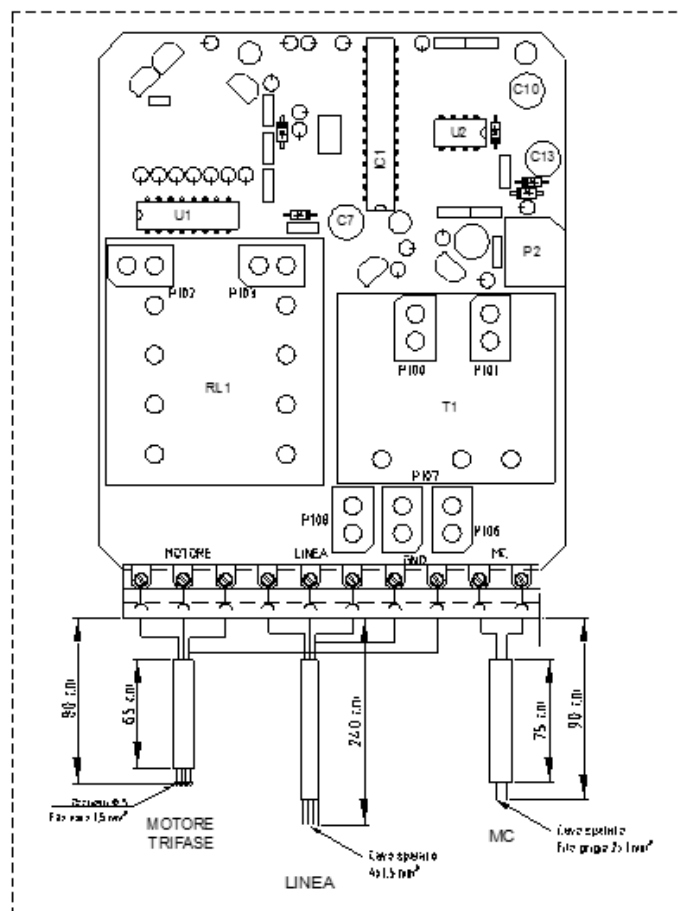

7.15 WIRING DIAGRAM THREE-PHASE – 2 SPEEDS TS/TSA12-18-38-44-60

(SCHEMA ELETTRICO IMPIANTO TRIFASE – 2 VELOCITA')

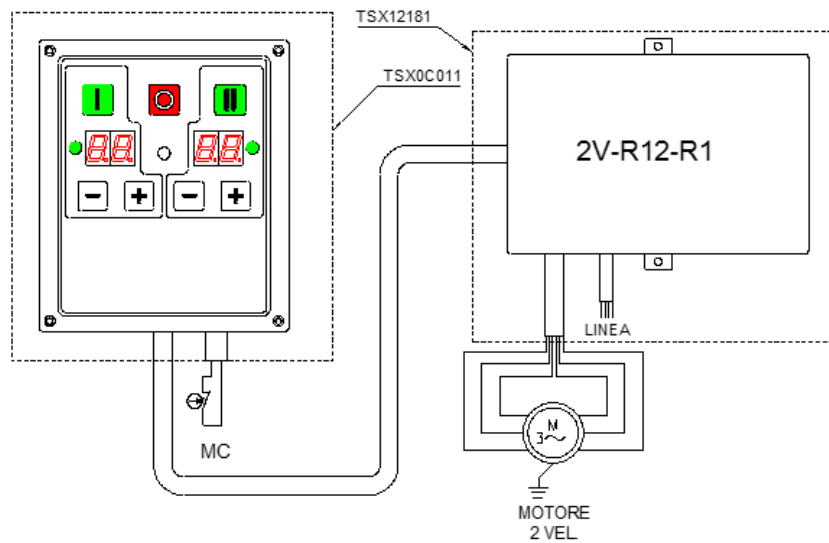

DETAILS OF CONNECTIONS TO ELECTRICAL BOARD OF THREE-PHASE- 2 SPEEDS ELECTRIC SYSTEM (DETTAGLI DEI COLLEGAMENTI ALLA SCHEDA DIGITALE IMPIANTO TRIFASE)

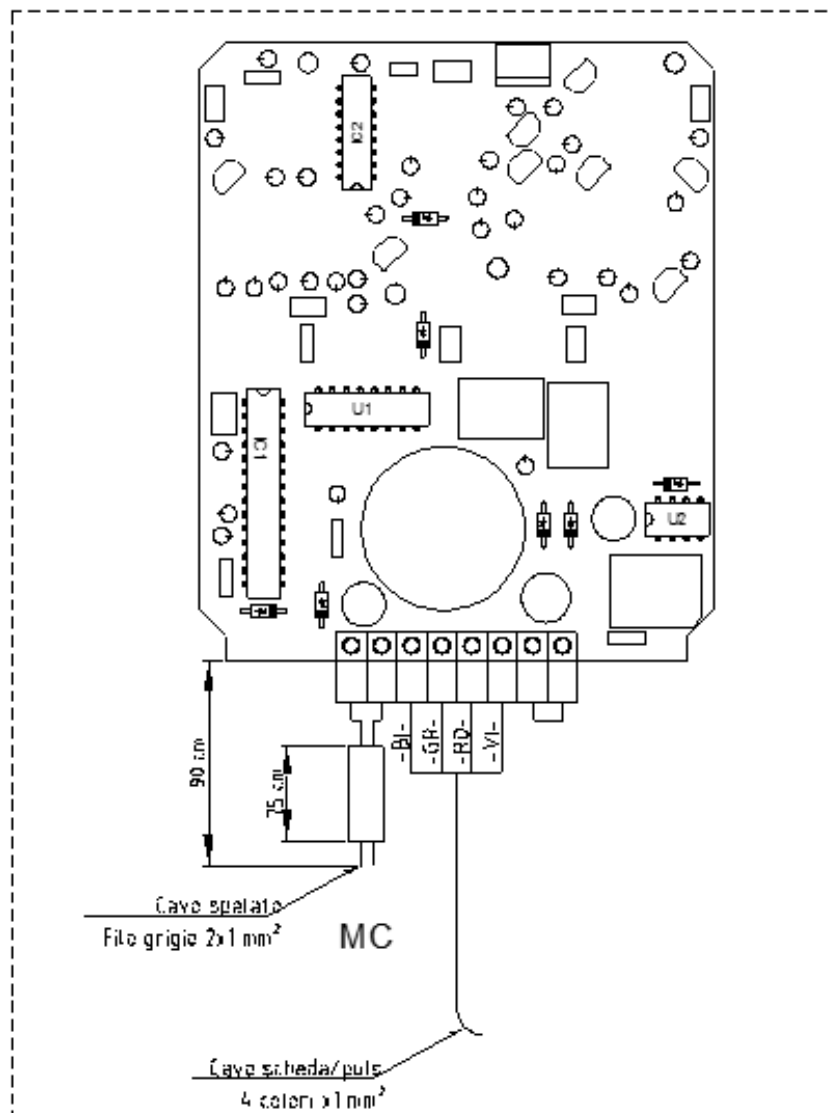

DETAILS OF CONNECTIONS TO POWER BOARD OF THREE-PHASE- 2 SPEEDS ELECTRIC SYSTEM

(*DETTAGLI DEI COLLEGAMENTI ALLA SCHEDA DI POTENZA IMPIANTO TRIFASE 2 VELOCITÀ*)

