

09/2013

Mod: PCF-A2

Production code: MQOF0A200000



Diamond
catering equipment

GENERAL

Facts & weight

FACTS	A-2	DA-4	Thermos A	Mega Gold A
Height, Width, Depth	428, 205, 410 mm	428, 410, 410 mm	557, 205, 410 mm	655, 205, 445 mm
Thermos/decanter volume	1.8 L	2x1.8 L	2.2 L	2.5 L
Power supply	220-230V 1N ~ 2390W 50/60Hz	400V 2N ~ 4780 W	220-230V 1N ~ 2200W 50/60Hz	220-230V 1N ~ 2200W 50/60Hz
Brew Options	4-12 Cups	4-12 Cups	4-15 Cups	4-17 Cups
Capacity	15 L/h	30 L/h	15 L/h	19 L/h
Brew time	6min	6min	7min	8.5min
Hot plates	2	4	None	None
Water connection	Cold water 1/2 R*			

MODEL/NAME	A-2	DA-4	Thermos A	Mega Gold A
Weight	9 kg	15.5 kg	10 kg	11.5 kg

General function description

- The Coffee brewer is equipped with a key pad for automatic water filling.
- The key pad allows you to adjust the number of cups for each brewing.
- The water tank is fitted with a float switch that will activate heating unit when water is filled, this starts the brew process. During the brewing process a lamp will be lit on the machine's right side. When the tank is empty of water the heater unit will be switched off and the lamp will be turned off.
- A brew process takes around 6–8.5min to complete.

DIMENSION

PCF-A2

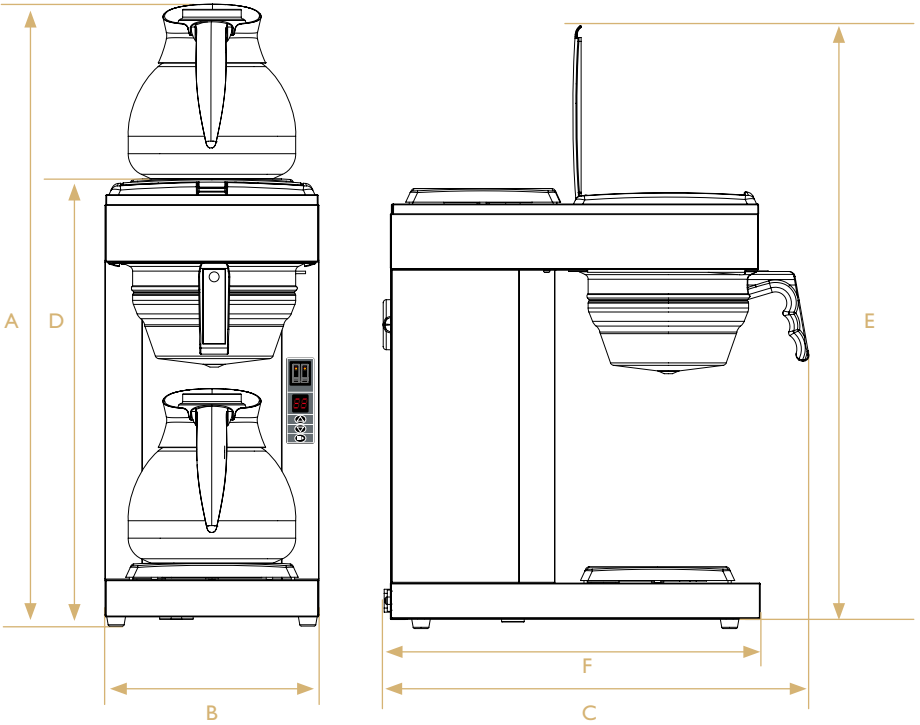

Model	A	B	C	D	E	F
PCF-A2	595mm	205mm	410mm	428mm	578mm	360mm