



MOD : GMB/200I

Production code : P432 31360

02/2026

INSTALLATION, GEBRAUCH UND WARTUNG

GAS-KOCHKESSEL MIT INDIREKTER BEHEIZUNG

**MOD.
GMB/200I**



LESEN SIE DIE BETRIEBSANLEITUNG VOR DEM GEBRAUCH DES GERÄTES AUFMERKSAM DURCH.

GERÄTESCHILD





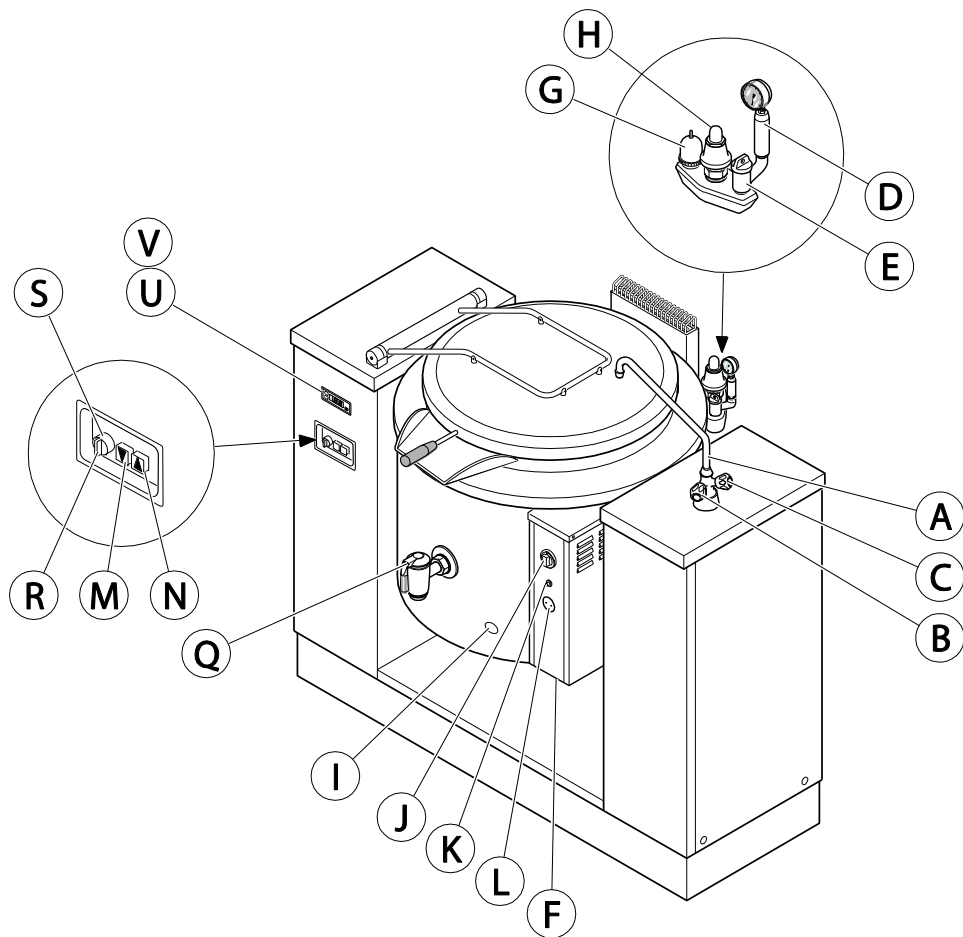

DE

- A Wasserverteilerstutzen
- B Warmwasserhahn
- C Kaltwasserhahn
- D Druckmesser
- E Schraubverschluss der Zwischenraum
- F Kontrolle des oberen Wasserstands in der Zwischenraum
- G Unterdruckventil Zwischenraum
- H Sicherheitsventil der Zwischenraum
- I Schauloch zur Flammeninspektion
- J Drehknopf Gashahn
- K Piezozündungsknopf
- L Tastenabdeckung Sicherheitsthermostat
- M Behälterkipptaste
- N Behälterrückföhrtaste
- R Einschalter
- S Einschaltkontrollleuchte
- Zubehör auf anfrage
- Q Grosser Ablaufshahn
- U Behältertemperaturregler
- V Kochzeitschaltuhr

CONTENTS	PAGE
I	INSTALLATION INSTRUCTIONS..... 18
1	GENERAL WARNINGS..... 18
2	COMPLIANCE WITH EEC DIRECTIVES..... 18
3	DATA PLATE..... 18
4	TRANSPORT AND STORAGE..... 19
4.1	Transport..... 19
4.2	Storage..... 19
5	INSTALLATION..... 19
5.1	PLACE OF INSTALLATION..... 19
5.2	POSITIONING..... 19
5.2.1	Unpacking..... 19
5.2.2	Positioning..... 19
5.2.3	Fastening..... 19
5.3	HYDRAULIC CONNECTION AND DRAIN CONNECTOR..... 19
5.4	ELECTRICAL CONNECTION..... 20
5.4.1	Installing the power cord and the equipotential connection..... 20
5.5	CONNECTION WITH GAS NETWORK..... 20
5.6	EXHAUST OF BURNT GASES..... 20
5.6.1	Underhood installation and forced exhaust..... 20
6	STARTING PROCEDURE..... 21
6.1	CONTROLLING THE CONNECTION PRESSURE..... 21
6.2	PRIMARY AIR ADJUSTMENT..... 21
6.3	ADJUSTING THE PILOT BURNER..... 21
6.4	ADAPTATION TO ANOTHER TYPE OF GAS..... 21
6.4.1	Replacing the nozzles of main burners..... 21
6.4.2	Replacing the nozzle of pilot burner..... 21
6.4.3	Replacing the nozzle of minimum flow bypass..... 21
6.4.4	Adjusting the minimum flow bypass..... 21
7	CHECKING THE OPERATION..... 21
8	MAINTENANCE..... 22
8.1	MALFUNCTIONING AND TROUBLESHOOTING..... 22
8.2	REPLACING COMPONENTS..... 22
II	OPERATING INSTRUCTIONS..... 24
1	WARNINGS..... 24
2	STARTING THE APPLIANCE..... 24
3	FILLING THE JACKET WITH WATER..... 24
3.1	Manual filling..... 24
3.2	Automatic filling..... 24
4	FILLING THE TANK..... 24
5	HEATING..... 24
6	AT THE END OF COOKING OPERATIONS..... 25
6.1	Extinguishing the burner..... 25
6.2	Tipping the cooked product..... 25
6.2.1	Emptying tap..... 25
6.3	End of the operations..... 25
7	SAFETY AND CHECKING DEVICES..... 25
8	CLEANING AND MAINTENANCE..... 26
9	IMPORTANT ADVICES..... 26
APPENDIX:	Technical data..... 75

When the equipment is connected directly with the mains, it must also be provided with a device ensuring the disconnection from the mains, with an opening distance of its contacts that enables its total disconnection in the conditions of overvoltage category III, according to the installation standards.

This breaker must always be accessible after the equipment has been installed.

When the power cord is damaged, it must be replaced by a skilled engineer so that any risk can be avoided.

Furthermore the equipment must be connected with an equipotential system. This connection must be carried out through the setscrew marked by symbol 

This appliance must be installed in compliance with current regulations and used only in a well-ventilated place.

The equipment must be connected with the water network permanently. Do not use flexible hoses.

Inlet pressure must range between 100 and 250 kPa (1 and 2,5 bar).

Never remove the screw plug closing the jacket port nor open the level control cocks or other draining devices when the appliance is working or it is still hot. Wait until its pressure drops down to atmospheric pressure.

When washing the equipment, do not flush out.

I - INSTALLATION INSTRUCTIONS

1 - GENERAL WARNINGS

- This equipment must be installed by skilled personnel according to manufacturer's instructions.
- Read the directions included in this handbook carefully because they supply important information concerning safety of installation, use and maintenance.
- Keep this handbook for any further consultation of various operators.
- After unpacking the equipment, make sure of its integrity. In case of any doubt, do not use the equipment and call the authorized dealer.
- All the packing materials comply with the standards of environmental protection.
They can be stored without any danger, or be burnt in a suitable waste incineration plant.
The components of plastic material that can be recycled are marked as indicated here below:



POLYETHYLENE: outer packing film, handbook bag, bag of nozzles.



POLYPROPYLENE: packing top panels, straps, etc.

- Before connecting the equipment make sure that its rating will correspond to the data of the mains and of the gas and water distribution networks.
- This equipment must exclusively be used by personnel trained in its use in a demonstrable way.
- Before carrying out any cleaning and servicing operation, disconnect the equipment from the mains and from the gas network.
- **DANGER OF FIRE – The area around the equipment must be kept clean and free from fuels. Do not keep any flammable material near this equipment.**
- Install the equipment in a place with a good ventilation to prevent the creation of dangerous mixtures of unburned gases.
- When determining the air recirculation, consider the necessary air for combustion: 1,72 m³/h per kW of gas power, as well as the "comfort" of the people working in the kitchen.
- A wrong ventilation can lead to suffocation. Never obstruct the ventilation system of the room where this equipment is installed. The exhaust and air vents of all appliances must never be obstructed.
- **Emergency telephone numbers must always be well visible.**
- This equipment has been designed for food cooking and for an industrial use. Using it for different aims has to be considered illegitimate.
- This equipment must not be used by people (such as children) with reduced physical, sensory or mental abilities, or without any experience and knowledge, unless a person responsible of their safety supervises and trains them to use it.
- People under the effects of drugs, alcohol, medicines compromising their mental alertness

cannot use the equipment nor carry out any servicing or repair operation.

- Monitor the equipment during its operation.
- In case of any fault or malfunction, disconnect the equipment from the mains immediately.
- When washing the equipment, do not flush out.
- Do not use any product (even diluted) containing chlorine (sodium hypochlorite, hydrochloric acid, etc..) to clean the equipment or the floor under it. Do not use any metallic tool (metallic brush or steel wool) to clean the steel parts.
- Avoid that oil or grease come into contact with parts of plastic material.
- Do not allow that the equipment becomes incrustated with dirt, greases, leftovers or with other substances.
- Dispose of this equipment responsibly. Our products are manufactured with recyclable metals (stainless steel, iron, aluminium, galvanized sheet, copper, etc..) for over 90% of their weight. When disposing of this equipment, first of all remove the power cord and any cover closing compartments or recesses to avoid that somebody can be kept closed inside.
- If any leaks from the hydraulic circuit occur, contact the technical assistance service to correct the causes.

The spilled hydraulic fluid is to be collected and not disposed of in the environment.

- The product must not be considered as domestic waste, but it has to be disposed correctly, to prevent any negative consequence on the environment and on human health. For further information on the recycling of this product, contact the local agent or dealer, the after-sales service or the local body charged with waste disposal.

Not complying with what recommended above could jeopardize the equipment safety and invalidate the manufacturer's warranty.

The manufacturer declines any responsibility for damages due to wrong installation, tampering, illegitimate use, poor servicing of the equipment, non-compliance of local standards and inexperience of use.

2 - COMPLIANCE WITH EEC DIRECTIVES

This equipment has been manufactured in compliance with the requirements stated by the directives of European Union:

- 2006/95/EU (Low voltage)
- 2004/108/EU (Electromagnetic Compatibility)
- 2016/426/EU (Gas appliances)
- 2006/42/CE (Machines)

3 – DATA PLATE (Fig. 1)

The plate indicating the equipment characteristics is applied onto the front panel. All the necessary data are included.

4 - TRANSPORT AND STORAGE

4.1 - Transport

The equipment is packed in a wooden crate that can be moved on vehicles for pallets.

Transport only one crate at a time.

- Handle the equipment with care to avoid any damage or danger for people.
- When the machine without packing is carried by fork-lift trucks, it must be supported on the two lines marked * on the installation drawing.

4.2 - Storage

Store the equipment indoors in a ventilated place, with a temperature ranging from -10°C to +50°C and humidity up to 95%.

Do not superimpose more the crates.

5 - INSTALLATION

- The operations of installation, maintenance and adaptation to another type of gas must be carried exclusively by skilled personnel authorized by the manufacturer.
- Read the installation and maintenance instructions available in this handbook before installing the equipment.

Not complying with the correct procedures of installation, adaptation and modification can provoke damages to the equipment and danger for people, besides invalidating Manufacturer's warranty.

5.1 - PLACE OF INSTALLATION

Install the equipment only in well-ventilated rooms. Connections, setup, ventilation and exhaust of fumes must be carried out according to manufacturer's instructions, in compliance with the standards in force (refer to step 5.6).

5.2 - POSITIONING

5.2.1 - Unpacking

CAUTION! Check immediately for any damages occurred during the transport.

- The forwarding agent is responsible of the safety of goods during the transport and the delivery.
- Check the packing materials before and after unloading.
- Lodge any complaint with the forwarding agent, in case of visible and concealed damages, signalling them on the shipping note at the delivery.
- The driver must sign the shipping note: the forwarding agent can reject the complaint if the shipping note has not been signed (the forwarding agent can supply the necessary form).
- Solicit the forwarding agent for the inspection of goods for concealed damages or missing parts, that are noticeable after unpacking the goods, within 15 days from the delivery.

- Remove the packing material caring not to damage the equipment. Wear protection gloves.
- Tear the film protecting the metallic surfaces off slowly, and clean any remains of glue with a suitable solvent.
- Keep all the documents contained in the package.

5.2.2 - Positioning

- The installation diagram available in this handbook indicates the overall dimensions of the equipment and the position of gas, power, water connections. Make sure that the installation place is provided with all the necessary connection points
- Arrange the equipment under an extractor hood for the extraction of vapours emitted during the cooking.
- Place the appliance on a smooth and level floor. A wrong levelling could lead to malfunctioning.
- It is important that the walls around the appliance be made with fireproof materials and protected against the heat. Do not store nor use flammable materials and liquids near the equipment.
- Do not place any cabinets next to the two columns; position the appliance at a sufficient distance from the walls, in order to allow access for maintenance and inspection.
- Keep a free safety space behind the tank (indicated by an **S** on the installation drawing), as set down by applicable standards.

5.2.3 – Fastening

The appliance must be firmly attached to the floor before being put into operation.

- Remove the side panels to access the two inspection compartments.
- Using a masonry bit, start the four holes for the expansion bolts to match the holes on the baseplate, shown by # in the installation drawing.
- Move the appliance away.
- Finish the holes with a Ø 20 mm bit, clean the floor and insert SLM - M12 expansion bolts.
- Reposition the appliance, insert the M12 screws and tighten them fully

5.3 HYDRAULIC CONNECTION AND DRAIN CONNECTOR (Installation diagram enclosed)

The equipment must be connected with the water network permanently according to what stated by the national standards in force and by EN 1717.

- Connect water inlet pipes "HWI" and "CWI" to the water network via shut-off valves and proper mechanical filters. Do not use flexible hoses.
- Inlet pressure must range between 100 and 250 kPa (1 and 2,5 bar).

CAUTION! If water pressure is higher than the value indicated, use a pressure reducer to avoid any damage to the equipment.

- The water used to produce steam and cook foods must be suitable to human consumption, besides having the following characteristics:

- Total hardness: 0,5 to 5 French degrees;
- Chloride ion (Cl) concentration: ~10 p.p.m.;
- PH higher than 7;
- Electrical conductivity: 50 to 2000 $\mu\text{S}/\text{cm}$ at 20°C.
- Before connecting the last piping section with the cooker, it is better to drain a certain quantity of water so that pipes are cleared from any iron slags that could trigger corrosion processes in stainless sheet steel.

CAUTION! Using water with different technical characteristics from those specified above will invalidate the product warranty.

When removing scales, do not use polyphosphates because they could compromise the good operation of the equipment.

- Install a drain with a stench trap under the tank emptying spout.

Drain pipes must be of heat-resistant material (up to 100 °C, at least).

5.4 - ELECTRICAL CONNECTION

The connection with the mains must comply with the standards in force.

- Before connecting the equipment with a power supply, make sure that the voltage and frequency of the power supply unit correspond to the operational data indicated on the data plate. When the equipment is working, the deviation of the supply voltage from the rated voltage must not exceed $\pm 10\%$.
- When the equipment is connected directly with the mains, it must also be provided with a device ensuring the disconnection from the mains, with an opening distance of its contacts that enables its total disconnection in the conditions of overvoltage category III, according to the installation standards. This breaker must always be accessible after the equipment has been installed.
- The equipment is supplied without power cord. The characteristics of the flexible cable for the connection with the mains must not be lower than those of the type with rubber insulation H05RN-F, its nominal section must be that indicated in Table 3; moreover this cable must be protected by a tube of metal or of rigid plastic. When the power cord is damaged, it must be replaced by a skilled engineer so that any risk can be avoided.
- The equipment must absolutely be connected with an efficient earthing jack. At this purpose, the earthing wire must be connected with the terminal marked by symbol \perp , available in the connection terminal strip.
- Furthermore the equipment must be connected with an equipotential system. This connection must be carried out through the setscrew marked by symbol ∇ . The equipotential wire must have a section of 10 mm^2 .
- The earthing and equipotential systems must comply with the standards in force and they have to be checked periodically.

The manufacturer declines any responsibility in case of non compliance with these standards of accident prevention.

5.4.1- Installing the power cord and the equipotential connection

- The access to the terminal strip for the connection of the power cord can be gained after the following operations:
- Remove the inspection panel.
- Connect the equipotential wire with terminal ∇ .
- Insert the cable and connect it with the terminal strip according to what indicated in the wiring diagram; then fasten it with the strain relief.

ATTENTION!

When the electrical connections are completed, check the direction of rotation of the pump motor:

- **Lift the lid completely. Turn the knob of switch "R" to the ON position, then press the lift push button ∇ "M" for an instant..**
The motor must turn in the direction of the arrow on the fan guard.
- **If the motor turns in the wrong direction, exchange two cables of the three-phase electrical connection and check again.**

- Reassemble the panel.

5.5 - CONNECTION WITH GAS NETWORK

- Before connecting the equipment with the gas network, check on the data plate that the equipment has been designed for the type of gas available by the user. Otherwise, follow the indications of section 6.4 "Adaptation to another type of gas".
- A quick-closing shut-off valve has to be inserted before each appliance in a place of easy access.
- This connection must always be performed with 3-piece connectors for an easy disassembly. Pipes must be of galvanized metal or of copper and they will be well visible. Even flexible hoses can be used provided they are of stainless steel.
- After connecting the equipment, check the tightness of the joints with a foaming spray.
- Remember that the air needed for combustion is equal to 2 m^3/h per kW of installed power and that the Standards of accident prevention must be complied with.

5.6 - EXHAUST OF BURNT GASES

5.6.1 - Underhood installation and forced exhaust

- This appliance is classified as **A1**, therefore it must compulsorily be positioned under an extractor hood so that fumes and vapours emitted during the cooking can be extracted.
- The gas supply must be interlocked directly with the system of forced exhaust and it must be cut off when its flow rate is reduced below the values stated by the standards. Then the gas must be supplied again to the equipment only manually.
- The system flow rate per hour must be equal to at least 1,72 m^3/h per kW referred to the total rated

thermal output of power consuming appliances present in the installation room, it being understood that the air exchange of the installation room can be sized for other aims not exclusively concerning the safety of the systems burning gas fuel.

Exhaust of fumes must not be prevented by obstructions.

6 - STARTING PROCEDURE

As regards the ignition of burners, refer to the chapter "II - OPERATING INSTRUCTIONS".

CAUTION!

Before lighting the burners, make sure that the jacket is filled with water up to the maximum level (refer to chapter II, section 3).

6.1 - CONTROLLING THE CONNECTION PRESSURE

The supply pressure can be measured with a U-tube or electronic pressure gauge with minimum resolution of 0,1 mbar.

- Loosen the screw "1" on the pressure intake "2" (Fig.3)
- Insert the pressure gauge.
- Light the burner and check that the pressure is that indicated in Table 5.
- Once ended the operation, reassemble and check the tightness.

If the connection pressure is not included in the indicated range the equipment cannot guarantee a good operation. In this case inform the gas distribution company.

6.2 - PRIMARY AIR ADJUSTMENT

The primary air is fixed so it doesn't need any adjustment.

6.3 - ADJUSTING THE PILOT BURNER

- Check that the flame wraps up the thermocouple and its aspect is correct. If this is not the case, check that the assembled nozzle is that designed for the line gas (refer to table 4).

6.4 - ADAPTATION TO ANOTHER TYPE OF GAS

This equipment can also work with a different gas from that chosen by the manufacturer: for instance, it can be enabled to burn liquid gas instead of natural gas; in this case it is necessary to replace the nozzles of the main burners, of pilot burner and the minimum flow bypass (refer to Table 4). All the necessary nozzles for this adjustment are available in a small bag supplied with the equipment.

Note: After adapting the equipment to a different type of gas from that chosen by the manufacturer, apply the right sticker (available in the bag of nozzles), referred to the new type of gas, onto the data plate covering the previous indications.

6.4.1 - Replacing the nozzles of main burners

(Fig. 6)

- Operating from the lower part of the pan, unscrew the injectors "1" and replace them with the proper ones for the type of gas chosen, as indicated in the table.

The nozzle diameter is indicated in hundredths of mm on the nozzle body.

- Tighten the new nozzles.

6.4.2 - Replacing the nozzle of pilot burner (Fig. 7)

- Unscrew the screw "4" of gas pipe.
- Remove nozzle "5" and replace it with the suitable one.

The number identifying the nozzle is indicated on the body of the same nozzle.

- Tighten screw "4" firmly.

6.4.3 - Replacing the nozzle of minimum flow bypass (Fig. 5)

- Unscrew the minimum flow nozzle "1" from the gas valve and replace with that suitable for the chosen type of gas screwing it tightly.

The nozzle diameter is indicated in hundredths of mm on the nozzle body.

6.4.4 - Adjusting the minimum flow bypass (Fig. 5)

- Ignite the main burner and turn the knob to maximum for a couple of minutes; then turn the knob to minimum.
- For liquid gas, the minimum adjustment screw "1" must be fully screwed.
- For natural gas, adjust the flow: to lower it, turn the screw "1" clockwise; to increase it, turn it counterclockwise.
- A burner is properly adjusted if there is no backfire when the burner is hot or flame lift when the burner is cold; also, the flame should not go out if the knob is rotated rapidly from maximum to minimum.
- Check that the burner can also be ignited in the minimum position.

Note: after replacing the parts of gas pipe, make always sure of the perfect tightness of the same pipe with a foaming spray.

Carry out checks and adjustments according to steps 6.1 – 6.3 – 6.4.4.

7 - CHECKING THE OPERATION

- Set the equipment at work according to the operating instructions.
- Make sure of the tightness of gas system.
- Check the flame ignition and stability, either at the maximum flow rate and at the minimum flow rate.
- Check the effectiveness of fume exhaust system.
- Check the operation of the safety valve.
- Check the balance of the lid.
- Check that there are no oil leaks from the flexible tubes or their connections.
- Check the efficiency of operation of the microswitch that enables tipping only if the lid is completely raised.

- Check the efficiency of operation of the microswitch that enables the ignition of the burner only if the tank is in vertical position.
- Train the user on the operation and maintenance of the equipment referring to the operational handbook, informing particularly of all the warnings having to be complied with for a correct use.

8 - MAINTENANCE

All the components having to be serviced are accessible after the removal of the panels. Hydraulic equipment and lid adjustment devices are outside the pan.

- Every 100 hours of operation, check the level of the oil in the hydraulic unit: the tank must not be less than 50% full (Fig. 2).
- When topping up, use AGIP OSO 46 or SHELL TELLUS 46 oil.

8.1- MALFUNCTIONING AND TROUBLESHOOTING

The pilot burner does not light up

Possible causes:

- The sparker plug is not fixed firmly or it has not been connected correctly.
- The piezoelectric lighter or the plug cable are damaged.
- Pressure in gas pipes is insufficient.
- The nozzle is clogged.
- The gas valve is faulty.

The pilot burner went out after the ignition knob is released

Possible causes:

- The thermocouple is not sufficiently heated by the pilot burner.
- The thermocouple is faulty.
- The gas knob is not pressed sufficiently.
- There is no gas pressure at the valve.
- The gas valve is faulty.
- The safety thermostat is faulty and it has tripped.
- An electric cable of the thermostat is disconnected.

The pilot burner is kept on, but the main burner does not light up

Possible causes:

- Pressure drop in the gas pipe.
- Clogged nozzle or faulty gas valve.
- Burner with gas outlet holes clogged.
- Fault of gas solenoid valve or of its electric controls.
- Malfunction or improper adjustment of tilting microswitch.
- Lack of power supply or tripped fuses.

When the push button is pressed, the tank does not tip over

Possible causes:

- Lack or overheating of the oil or impurities in the oil in the hydraulic unit.
- Jamming or faulty adjustment of the solenoids.
- Malfunction or faulty adjustment of lid opening microswitch.
- Lack of power supply or tripped fuses.

Tripping of safety thermostat

- The equipment is provided with a safety thermostat that cuts off the gas supply to the main burner in case of anomalous operation or dry operation.
- After eliminating the tripping cause, remove the protection cap "L" from the control board and press the underlying red button to restart the operation.

This operation must be carried out by a skilled engineer.

WARNING: tampering with the thermostat will invalidate the warranty.

8.2 - REPLACING COMPONENTS

Caution! Any part of the equipment must be replaced by authorized personnel using original spare parts.

To request spare parts, always indicate the serial number of the equipment.

Discharge the oil pressure before operating on the hydraulic system.

Piezoelectric lighter and cable

- Dismantle the lighter from the panel.
- Disconnect the cable and cut the hose clamps.
- Replace the component and fasten the cable again with suitable hose clamps.

Sparker plug (Fig. 7 "1")

Work from below the casing.

- Disconnect the cable from the plug.
- Unscrew lock nut "6".
Replace the component and reassemble according to the opposite sequence.

Thermocouple (Fig. 7 "2" e Fig. 4)

- Remove the panels.
- Unscrew the screws "7" from the pilot set and "3" of gas valve.
- Replace the component and fasten it again with suitable hose clamps.
- Reassemble the components and the panels according to the opposite sequence.

Pilot burner (Fig. 7 "3")

Work from below the casing.

- Unscrew and remove thermocouple "2", gas connector "4" and sparker plug "1".
- Remove nozzle "5" and store it. Disassemble pilot burner "3" and replace with the new one.
- Reassemble the whole unit according to the opposite sequence of disassembling operations.
- Check the tightness.

Main burner (Fig. 6)

Work from below the casing.

- Remove the screws fastening the burner set onto its own support and extract it from the casing.
- Remove the screws that fasten each burner element to the header.
- When installing the burner, carry out the same operations in opposite sequence.

Gas valve (Fig. 4)

- Remove the panels.

- Unscrew the pipe of pilot burner "2" and of thermocouple "3".
- Unscrew gas inlet and outlet connectors "4" and "5".
- Remove the screws fastening the valve onto its own support.
- Replace the component reassembling according to the opposite sequence.
- Before reassembling the panels check the tightness.

Pressure switch, gas solenoid valve

- Remove the panels.
- Replace the component reassembling according to the opposite sequence.
- Before reassembling the panels check the tightness.

Electrical components

- Remove the left side panel.
- Microswitches, push buttons, motor: they are readily accessible.
- Fuses, transformer, contactors, noise filter: placed on the control panel.

Hydraulic components

- Remove the left side panel.
- Hydraulic unit, solenoids, flexible tubes, piston: they are readily accessible.

Lid balancing springs

- Work with the lid closed.
- Release and extract the hinge pivots. The springs are immediately accessible.
- Replace the spring and reassemble the parts in reverse order, recharge the springs up to perfect balancing of the lid and lock the hinges.

CAUTION!

The springs are preloaded, hold the pivots firmly while releasing them.

Drain cock

- Unscrew the lock nut carefully with the specific key.
- Take care not to damage the chrome plating and not to unscrew the hose for the connection with the tank.
- Before reassembling, replace the gasket, if necessary.

II - OPERATING INSTRUCTIONS

This appliance has been designed to cook food in aqueous medium and it must be used exclusively by skilled personnel complying with these operating instructions. Any other illegitimate use is dangerous.

1 - WARNINGS

- Read these operating instructions carefully because they give important information about the safety of installation, use and maintenance.
- Keep this handbook with care so that it can be consulted in any time.
- The installation of this equipment and its possible adaptation to other types of gas must be performed exclusively by skilled personnel.
- For any repair refer to the nearest after-sales centre authorized by the manufacturer and require original spare parts exclusively.

Not complying with this instruction will compromise the safety of the equipment and invalidate the manufacturer's warranty.

2 - STARTING THE APPLIANCE (Page 4)

- Before setting the appliance at work, wash the cooker inside with hot water and detergent, then rinse out with plenty of water.
- Our appliances offer high performance. Do not use the appliance without load nor in conditions compromising its optimum performance (with open doors or lids, for instance) in order to reduce the consumptions of electric power, water or gas.
- When possible, pre-heat the equipment only before use.

CAUTION!

Never set the equipment at work before filling the jacket with water.

Not complying with this standard would provoke serious damages to the tank of stainless steel and to the other internal components for overheating.

3 - FILLING THE JACKET WITH WATER

Attention!

Every morning, when the appliance is cold, check that water does not drop below the minimum level:

- **Open for a few seconds the cock of maximum level "F" from which must always leave water.**

When possible, fill the jacket with deionized water whose hardness is not higher than 5 French degrees carrying out the following operations:

3.1 – Manual filling

- Remove the screw plug "E" closing the jacket port.
- Open the cock of maximum level "F".
- Pour decalcified water through the port until a continuous thin stream of water starts flowing out of cock "F".
- Screw plug "E" again carefully.

Do not load water over the maximum level.

Any excess must be left to flow through the same level cock.

3.2 - Automatic filling (optional)

- In the pans equipped with automatic level control, the amount of water in the jacket is stably maintained within the minimum and maximum levels, without the continuous intervention of the operator. The device is activated automatically after the appliance is powered.
- For the proper functioning of the system it is important that the water net pressure is within the values indicated in Appendix.
- With first use, automatic water filling takes about 120 minutes to bring the water in the jacket to the minimum level. For quicker water filling it is possible to proceed manually following the instructions in par. 3.1.
- In case of failure, as emergency solution pour the water manually following the instructions in par. 3.1.

Never remove the screw plug "E" closing the jacket port nor open the level control cocks or other draining devices when the appliance is working or it is still hot. Wait until its pressure drops down to atmospheric pressure.

4 - FILLING THE TANK

- Open the two cocks "B" and "C" of hot and cold water. The filling level will be at least 6 cm below the overflow edge.
- Close the lid.

5 - HEATING

- Power the equipment and supply gas by turning the switch on and acting on the valve installed before the appliance.
- Turn the knob of switch "R" to the ON position; the green warning light "S" will be ON indicating that the appliance is powered.
- Press and turn knob "J" counterclockwise from the OFF position to the position of PILOT LIGHTING.
- Knob "J" will control the gas valve and it has 4 positions of use.

● OFF

★ PILOT LIGHTING

🔥 FLAME AT MAX. POWER

🔥 FLAME AT MIN. POWER

- Press knob "J" completely and at the same time press the button of piezoelectric lighter "K" repeatedly: this will light the pilot flame. Approximately 20 seconds after the ignition of pilot flame, release the knob: the flame must go on burning. If this is not the case, repeat these operations.
- The lighting of pilot burner can be observed through inspection port "I".

- Turning knob "J" from the position of PILOT LIGHTING to the position of FLAME AT MAX. POWER or of FLAME AT MIN. POWER will enable to light the main burner.
- When the steam pressure in the jacket approaches 50 kPa (0,5 bar) the safety valve "H" will start to vent.
- At this point, depending on the type of food being cooked, the heat input will have to be lowered by rotating the gas valve knob to the MIN. FLAME position, so as to avoid steam leaks through the valve.
- In the cooking appliances provided with pressure switch, the pressure inside the jacket is controlled automatically: the pressure switch provokes the extinguishing and lighting of the burner via the solenoid valve so that pressure is kept at an optimum value and the consumption of jacket water is reduced.
- When the boiling point is reached, the heat input should be lowered by rotating the gas valve knob to the MIN. FLAME position, so as to improve the efficiency of the burner and avoid frequent interventions of the pressure switch.
- The pan can be equipped with other control devices, described at point 7. The relative instructions are supplied as required.

Note! Every time the equipment is set at work, after 10/15 minutes from the ignition allow air to escape from the jacket by pressing the button of air valve "G" (Fig. 9). That will ensure an optimum pressure inside the jacket (faster temperature rise and energy saving) because the inside air escapes.

6 - AT THE END OF COOKING OPERATIONS

6.1 - Extinguishing the burner

- At the end of cooking operations, turn knob "J" to the position of PILOT LIGHTING to extinguish only the main burner.



CAUTION!

Open the lid carefully to avoid scalds due to steam exhaust or to the contact with hot surfaces.

- Every day, when opening the lid, make sure that it is kept lifted before releasing its handle; every six months the balancing spring must be checked by a skilled engineer.

However, do not put your hands under the lid when this is lifted.

6.2 - Tipping the cooked product

- Stop heating by turning the knob "J" to the position OFF or PILOT IGNITION.
- Lift the pot lid and bring the container to be filled under the emptying spout.
- To tip the tank, keep the "M"  push button pressed.
- To return the tank to the vertical position, keep the "N"  push button pressed.

The tank can be tipped only when the lid is completely raised.

Use great care when tipping the pot: the cooked product can be very hot!

6.2.1 – Emptying tap

- On request, the pot can be supplied with a pot emptying tap "Q".
- For proper hygiene of the equipment, frequently clean the emptying tap.
- When the pan is not being used, it is good practice to let the emptying tap open to avoid water pooling in the drain passage.

Note! Lubricate cock "Q" with dietary fats regularly once a week to prevent any break and reduce its wear.

6.3 - End of the operations

- Turn the knob of gas valve "J" to the OFF position to extinguish the pilot burner.
- Turn the knob of switch "M" to the OFF position.
- Close the gas shutoff valve.
- Disconnect the automatic switch installed before the equipment.

7 - SAFETY AND CHECKING DEVICES

- Pressure gauge "D" that indicates the steam pressure in the jacket.
- Vent and vacuum valve "G" enabling the exhaust of the air inside the jacket.
- Screw plug "E" for the manual filling of jacket with water.
- Safety valve "H": being adjusted at 50 kPa (0,5 bar) it starts allowing steam to exhaust as the pressure in the jacket approaches this value. It is available in different versions:
 - Spring-loaded free-discharge type;
 - Spring-loaded ducted discharge type. The valve is provided with a ring nut that can be lifted for control venting.

Note: check the effectiveness of the safety valve when installing the equipment for the first time, and then every six months.

- Jacket maximum water level indicator cock "F".
- The water level in the jacket must be checked every day even if the appliance is provided with the automatic water loading system.**

- Safety thermostat: it trips to close the gas valve when the bottom wall is overheated for lack of water or for other causes.

After waiting until the appliance is cold and adding decalcified water in the jacket, restart the equipment operation unscrewing the protection cap "L" available on the control board of the pan and pressing the red push button.

- Tank safety microswitch: it cuts off the gas flow to the main burner when the tank tipping starts.
- Lid safety microswitch: it makes it possible to connect the tipping of the tank only when the lid is completely raised.

- On demand can be applied accessories such as:
 - Working pressure switch, calibrated at 40 kPa (0,4 bar): it enables to keep the jacket pressure adjusted in a range near this value.
 - Tank thermoregulator "U".
 - Cooking timer "V".
 The relative signals of "ON-OFF" type regulate the opening of the gas solenoid valve.
- The appliance can also be provided with an automatic system for controlling the water jacket level through a water feeding solenoid valve.

8 - CLEANING AND MAINTENANCE

Before starting any cleaning or servicing operation, disconnect always the power supply before the appliance.

- When cleaning the appliance (outside and, where necessary, inside), use only products with a biodegradability exceeding 90% to reduce the emission of pollutants in the environment.
- Wash the steel parts with soapy lukewarm water every day, then rinse out with plenty of water and dry carefully. Remove any scales with a nylon brush.
- Avoid any continuous or occasional contact with iron material absolutely not to trigger corrosion processes. Consequently ladles, spatulas, spoons, etc. must be of stainless steel.
- For the same reason do not clean stainless steel with wool, brushes or scrapers of common steel. If necessary, wipe with stainless steel wool or with a Scotch Brite™ cloth in the direction of glazing.
- Add salt only when water is boiling, and any leftovers must be eliminated immediately after the end of every cooking operation.
- Never use coarse salt because it could provoke corrosion phenomena on the tank bottom as it melts down very slowly. Therefore use fine salt (with grain size lower than 3 mm); if this is not available, dissolve the salt with hot water in a separate pot previously.
- If the equipment is not used for long periods, wipe all the steel surfaces strongly with a cloth soaked with white mineral oil to cover them with a protective film; moreover drain the water from the jacket and ventilate the rooms periodically.
- When the cooker is not used, its lid must be kept open.
- The equipment must undergo a total check periodically (at least once in a year). The efficiency of the safety devices and the lid balance must be checked by a skilled engineer at least every six months.
- Where installed, check every six months the water jacket automatic filling device. Clean if necessary probes from scale using pure vinegar or a solution of chemical cleaner (1/3) and water (2/3). This operation must be performed by a qualified technician.
- It is advisable to drain the jacket completely once in a year by opening the drain cap.

- Check frequently the level of the oil in the hydraulic unit tank.

9 - IMPORTANT ADVICES

- **When washing the equipment, do not flush out nor use water at high pressure because any infiltration in internal components could compromise the good operation and the safety.**
- **Do not use any product (even diluted) containing chlorine (bleach, hydrochloric acid, etc.) to clean the steel.**
- **Do not use any corrosive substance (e.g.: hydrochloric acid) to clean the floor under the equipment.**
- **The ventilation capacity for combustion and the electric system cannot absolutely be modified.**
- **This appliance is manufactured with recyclable metals (stainless steel, iron, aluminium galvanized sheet, copper, etc.) for over 90% of their weight, therefore these materials can be recycled in normal recycling facilities in compliance with the regulations in force in every country.**
- **When disposing of this equipment, first of all remove the power cord. Then remove also the lid to avoid that somebody can be kept closed inside the tank.**

DE. (kategorie II2ELL3B/P)

Modell			GMB.IG 100/l	GMB.IG 150/l
Faßungsvermögen Behälter:	bis Rand nutzbar	liter	110	145
		liter	100	135
Faßungsvermögen Zwischenraum:	min. Stand	liter	15	15
	max. Stand	liter	18	18
Berechnungsdruck Zwischenraum			kPa (bar)	50 (0,5) 50 (0,5)

Thermische Nennleistung	kW	26	
Thermische Mindestleistung	kW	9	
Gasverbrauch (berechnet mit unterem Heizwert "Hi" bei 15°C und 1013 mbar)			
Erdgas G20 (Hi= 34,02 MJ/m³)	m³/h	2,54	
Erdgas G25 (Hi= 29,25 MJ/m³)	m³/h	2,95	
Flüßiggas G30 (Hi= 45,65 MJ/kg)	kg/h	1,88	
Flüßiggas G31 (Hi= 46,34 MJ/kg)	kg/h	1,85	
Bauart			
		A1	
Druck des kalt - bzw. Warmwassers		kPa (bar)	100 – 250 (1,5 - 2,5)

Versorgungsspannung - Dreiphasig	VAC	220-240 / 380-415
Frequenz	Hz	50 / 60
Leistung	kW	0,37
Speisekabel	mm²	2,5

Gasart	Hauptbrennerdüse	Pilotbrennerdüse	By-pass	Luftposition des Hauptbrenners
	Ø 1/100 mm	N°	Ø 1/100 mm	H mm
Erdgas G20	3 x 205R	27	220	Ganz geöffnet, ohne Regelung
Erdgas G25	3 x 220R	27	230	Ganz geöffnet, ohne Regelung
Flüßiggas G30	3 x 135R	22	140	Ganz geöffnet, ohne Regelung
Flüßiggas G31	3 x 135R	22	140	Ganz geöffnet, ohne Regelung

Gasart	Gaszufuhr kW		Zufuhrdruck mbar			Verbrennungsluft m³/h
	Nenn	Reduziert	Nenn	Min.	Max.	
Erdgas G20	24	9	20	18	25	48
Erdgas G25	24	9	20	18	25	48
Flüßiggas G30	24	9	50	42,5	57,5	48
Flüßiggas G31	24	9	50	42,5	57,5	48

DE. (kategorie II2ELL3B/P)

Tabelle 1 – Allgemeine Daten			
Modell			GMB.IG 200
Faßungsvermögen Behälter:	bis Rand	litri	215
	nutzbar	litri	195
bis Rand	min. Stand		24
	max. Stand	liter	31
Berechnungsdruck Zwischenraum		kPa (bar)	50 (0,5)
Faßungsvermögen Zwischenraum		kPa (bar)	-

Tabelle 2 - Technische Angaben		
Thermische Nennleistung	kW	39
Thermische Mindestleistung	kW	21
Gasverbrauch (berechnet mit unterem Heizwert "Hi" a 15°C e 1013 mbar)		
Erdgas G20 (Hi= 34,02MJ/m³)	m³/h	4,13
Erdgas G25.3 (Hi= 29,92MJ/m³)	m³/h	4,69
Erdgas G25 (Hi= 29,25MJ/m³)	m³/h	4,80
Erdgas G25.1 (Hi= 29,30MJ/m³)	m³/h	4,79
Flüssiggas G30 (Hi= 34,02MJ/kg)	kg/h	3,08
Flüssiggas G31 (Hi= 34,02MJ/kg)	kg/h	3,03

Tabelle 3 - Elektrische Speisung		
Versorgungsspannung - Einphasig	VAC	220...230
Frequenz	Hz	50 /60
Leistung	kW	0,05
Speisekabel		3 x 1,5 mm²

Bauart		A1
Druck des kalt - bzw. Warmwassers	kPa (bar)	100 – 250 (1,5 - 2,5)

Tabelle 4 - Gasdüsen					
Gasart	Druck mbar	Hauptbrennerdüse Ø 1/100 mm	Pilotbrennerdüse N°	By-pass Ø 1/100 mm	Luftposition des Hauptbrenners H mm
Erdgas G20	20	5 x 205R	27.2	Einstellbar	Ganz geöffnet, ohne Regelung
Erdgas G20	25	5 x 190R	27.2	Einstellbar	Ganz geöffnet, ohne Regelung
Erdgas G25.3	25	5 x 210R	27.2	Einstellbar	Ganz geöffnet, ohne Regelung
Erdgas G25	20	5 x 220R	27.2	Einstellbar	Ganz geöffnet, ohne Regelung
Erdgas G25.1	25	5 x 210R	27.2	Einstellbar	Ganz geöffnet, ohne Regelung
Flüssiggas G30	28-30	5 x 145	22	Einstellbar	Ganz geöffnet, ohne Regelung
Flüssiggas G31	37	5 x 145	22	Einstellbar	Ganz geöffnet, ohne Regelung
Flüssiggas G30	30	5 x 145	22	Einstellbar	Ganz geöffnet, ohne Regelung
Flüssiggas G31	30	5 x 145	22	Einstellbar	Ganz geöffnet, ohne Regelung
Flüssiggas G30	50	5 x 125R	22	Einstellbar	Ganz geöffnet, ohne Regelung
Flüssiggas G31	50	5 x 125R	22	Einstellbar	Ganz geöffnet, ohne Regelung

Tabelle 5 - Gasanschluß

Gas familie	Gasart	Gaszufuhr kW		Zufuhrdruck mbar			Verbrennungsluft m³/h	* Düsenrampendruck bei minimaler Durchflussrate mbar
		Nenn	Reduziert	Nenn	Min.	Max.		
2H, 2E, 2E+	Erdgas G20	39	21	20	17	25	78	3,0
2H	Erdgas G20	39	21	25	18	33	78	3,7
2K	Erdgas G25.3	39	21	25	20	30	78	3,7
2LL, 2L	Erdgas G25	39	21	20	18	25	78	3,0
2S	Erdgas G25.1	39	21	25	18	33	78	3,7
3+	Flüßiggas G30	39	21	28-30	20	35	78	4,5
	Flüßiggas G31	39	21	37	25	45	78	4,5
3B/P	Flüßiggas G30	39	21	30	25	35	78	4,5
	Flüßiggas G31	39	21	29	25	35	78	4,5
3B/P	Flüßiggas G30	39	21	50	42,5	57,5	78	16,0
	Flüßiggas G30	39	21	50	42,5	57,5	78	16,0

DE. (kategorie II2ELL3B/P)

Tabelle 1 – Allgemeine Daten				
Modell			PTBC.IG 300	
Faßungsvermögen Behälter:	bis Rand	liter	330	
	nutzbar	liter	300	
bis Rand:	min. Stand	liter	50	
	max. Stand	liter	60	
Berechnungsdruck Zwischenraum		kPa (bar)	50 (0,5)	
Faßungsvermögen Zwischenraum		kPa (bar)	-	

Tabelle 2 - Technische Angaben		
Thermische Nennleistung	kW	48
Thermische Mindestleistung	kW	23
Gasverbrauch (berechnet mit unterem Heizwert "Hi" a 15°C e 1013 mbar)		
Erdgas G20 (Hi= 34,02MJ/m³)	m³/h	5,08
Erdgas G25.3 (Hi= 29,92MJ/m³)	m³/h	5,78
Erdgas G25 (Hi= 29,25MJ/m³)	m³/h	5,91
Flüssiggas G30 (Hi= 34,02MJ/kg)	kg/h	3,79
Flüssiggas G31 (Hi= 34,02MJ/kg)	kg/h	3,73

Bauart		A1
Druck des kalt - bzw. Warmwassers	kPa (bar)	100 – 250 (1,5 - 2,5)

Tabelle 3 - Elektrische Speisung		
Versorgungsspannung - Einphasig	VAC	220...230
Frequenz	Hz	50 /60
Leistung	kW	0,05
Speisekabel		3 x 1,5 mm²

Tabelle 4 - Gasdüsen					
Gasart	Druck mbar	Hauptbrennerdü se Ø 1/100 mm	Pilotbrennerdüse N°	By-pass Ø 1/100 mm	Luftposition des Hauptbrenners H mm
Erdgas G20	20	5 x 230R	27.2	Einstellbar	Ganz geöffnet, ohne Regelung
Erdgas G25.3	25	5 x 235R	27.2	Einstellbar	Ganz geöffnet, ohne Regelung
Erdgas G25	20	5 x 255R	27.2	Einstellbar	Ganz geöffnet, ohne Regelung
Flüssiggas G30	28-30	5 x 155	22	Einstellbar	Ganz geöffnet, ohne Regelung
Flüssiggas G31	37	5 x 155	22	Einstellbar	Ganz geöffnet, ohne Regelung
Flüssiggas G30	30	5 x 155	22	Einstellbar	Ganz geöffnet, ohne Regelung
Flüssiggas G31	30	5 x 155	22	Einstellbar	Ganz geöffnet, ohne Regelung
Flüssiggas G30	50	5 x 135	22	Einstellbar	Ganz geöffnet, ohne Regelung
Flüssiggas G31	50	5 x 135	22	Einstellbar	Ganz geöffnet, ohne Regelung

Tabelle 5 - Gasanschluß

Gas familie	Gasart	Gaszufuhr kW		Zufuhrdruck mbar			Verbrennungsluft m³/h	* Düsenrampendruck bei minimaler Durchflussrate mbar
		Nenn	Reduziert	Nenn	Min.	Max.		
2H, 2E, 2E+	Erdgas G20	48	23	20	17	25	96	4,0
2K	Erdgas G25.3	48	23	25	20	30	96	5,0
2LL, 2L	Erdgas G25	48	23	20	18	25	96	4,0
3+	Flüssiggas G30	48	23	28-30	20	35	96	6,0
	Flüssiggas G31	48	23	37	25	45	96	6,0
3B/P	Flüssiggas G30	48	23	30	25	35	96	6,0
	Flüssiggas G31	48	23	29	25	35	96	6,0
3B/P	Flüssiggas G30	48	23	50	42,5	57,5	96	10,0
	Flüssiggas G30	48	23	50	42,5	57,5	96	10,0

DE. (kategorie II2ELL3B/P)

Tabelle 1 – Allgemeine Daten				
Modell			GMB.IG 500	
Faßungsvermögen Behälter:	bis Rand	liter	500	
	nutzbar	liter	460	
Faßungsvermögen Zwischenraum:	min. Stand	liter	68	
	max. Stand	liter	83	
Berechnungsdruck Zwischenraum		kPa (bar)	50 (0,5)	
Berechnungsdruck Behälter		kPa (bar)	-	

Tabelle 2 - Technische Angaben		
Thermische Nennleistung	kW	55
Thermische Mindestleistung	kW	16
Gasverbrauch (berechnet mit unterem Heizwert "Hi" a 15°C e 1013 mbar)		
Erdgas G20 (Hi= 34,02MJ/m³)	m³/h	5,82
Erdgas G25.3 (Hi= 29,92MJ/m³)	m³/h	6,62
Erdgas G25 (Hi= 29,25MJ/m³)	m³/h	6,77
Erdgas G25.1 (Hi= 29,30MJ/m³)	m³/h	6,76
Flüßiggas G30 (Hi= 34,02MJ/kg)	kg/h	4,34
Flüßiggas G31 (Hi= 34,02MJ/kg)	kg/h	4,27

Bauart		A1
Druck des kalt - bzw. Warmwassers	kPa (bar)	100 – 250 (1,5 - 2,5)

Tabelle 3 - Elektrische Speisung		
Versorgungsspannung - Einphasig	VAC	220...230
Frequenz	Hz	50 /60
Leistung	kW	0,05
Speisekabel		3 x 1,5 mm²

Tabelle 4 - Gasdüsen					
Gasart	Druck mbar	Hauptbrennerdüse ^e Ø 1/100 mm	Pilotbrennerdüse N°	By-pass Ø 1/100 mm	Luftposition des Hauptbrenners H mm
Erdgas G20	20	7 x 205R	27.2	Einstellbar	Ganz geöffnet, ohne Regelung
Erdgas G20	25	7 x 195R	27.2	Einstellbar	Ganz geöffnet, ohne Regelung
Erdgas G25.3	25	7 x 210R	27.2	Einstellbar	Ganz geöffnet, ohne Regelung
Erdgas G25	20	7 x 230R	27.2	Einstellbar	Ganz geöffnet, ohne Regelung
Erdgas G25.1	25	7 x 220R	27.2	Einstellbar	Ganz geöffnet, ohne Regelung
Flüßiggas G30	28-30	7 x 140	22	Einstellbar	Ganz geöffnet, ohne Regelung
Flüßiggas G31	37	7 x 140	22	Einstellbar	Ganz geöffnet, ohne Regelung
Flüßiggas G30	30	7 x 140	22	Einstellbar	Ganz geöffnet, ohne Regelung
Flüßiggas G31	30	7 x 140	22	Einstellbar	Ganz geöffnet, ohne Regelung
Flüßiggas G30	50	7 x 125R	22	Einstellbar	Ganz geöffnet, ohne Regelung
Flüßiggas G31	50	7 x 125R	22	Einstellbar	Ganz geöffnet, ohne Regelung

Tabelle 5 - Gasanschluß

Gas familie	Gasart	Gaszufuhr kW		Zufuhrdruck mbar			Verbrennungsluft m³/h	* Düsenrampendruck bei minimaler Durchflussrate mbar
		Nenn	Reduziert	Nenn	Min.	Max.		
2H, 2E, 2E+	Erdgas G20	55	16	20	17	25	110	1,5
2H	Erdgas G20	55	16	25	18	33	110	2,0
2K	Erdgas G25.3	55	16	25	20	30	110	2,0
2LL, 2L	Erdgas G25	55	16	20	18	25	110	1,5
2S	Erdgas G25.1	55	16	25	18	33	110	2,0
3+	Flüssiggas G30	55	16	28-30	20	35	110	2,5
	Flüssiggas G31	55	16	37	25	45	110	2,5
3B/P	Flüssiggas G30	55	16	30	25	35	110	2,5
	Gas liquido G31	55	16	29	25	35	110	2,5
3B/P	Gas liquido G30	55	16	50	42,5	57,5	110	4,0
	Gas liquido G30	55	16	50	42,5	57,5	110	4,0