



**MOD : DPA/PVV08-D**

**Production code : 8046400**

**02/2026**

# 11. SCHEMI DI MONTAGGIO E SPECIFICHE TECNICHE – DIAGRAMS AND TECHNICAL FEATURES - MONTAGEPLÄNE UND TECHNISCHE SPEZIFIKATIONEN - SCHÉMAS DE MONTAGE ET SPÉCIFICATIONS TECHNIQUES

Fig. 1: PANNELLO COMANDI – CONTROL PANEL – SCHALTFELD - PANNEAU DE COMMANDES

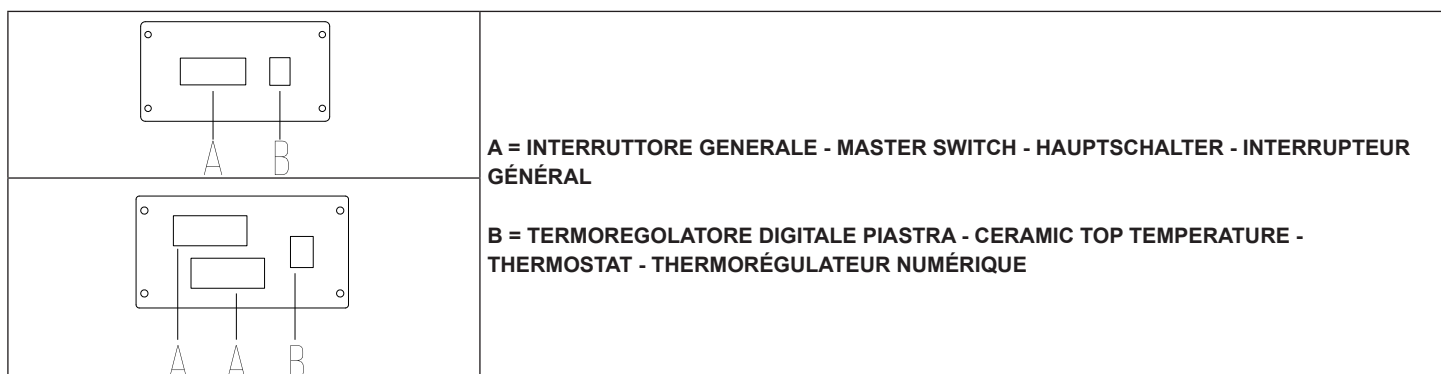

Fig. 2: PANNELLO COMANDI MECCANICO – MECHANIC CONTROL PANEL – MECHANISCHES BEDIENFELD - PANNEAU DE COMMANDES MÉCANIQUE

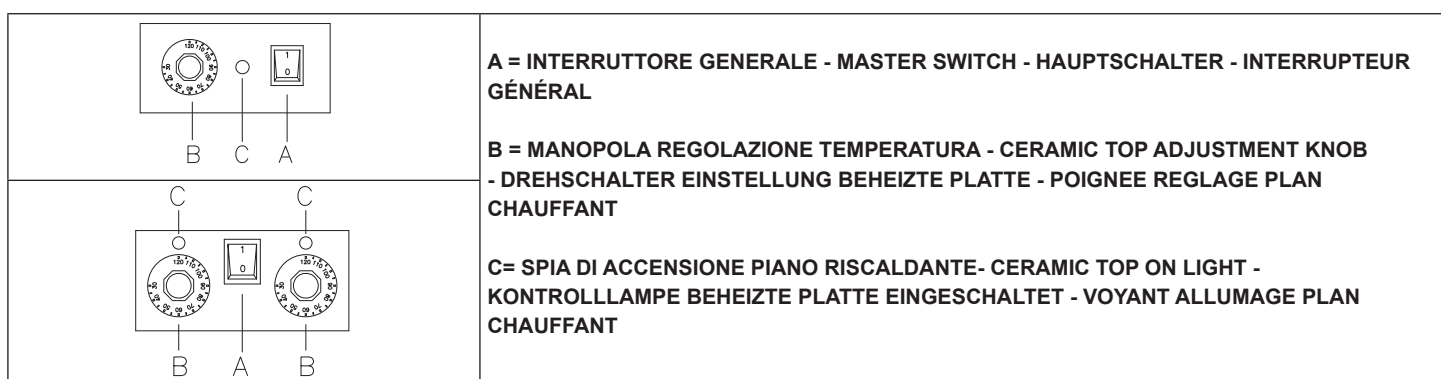
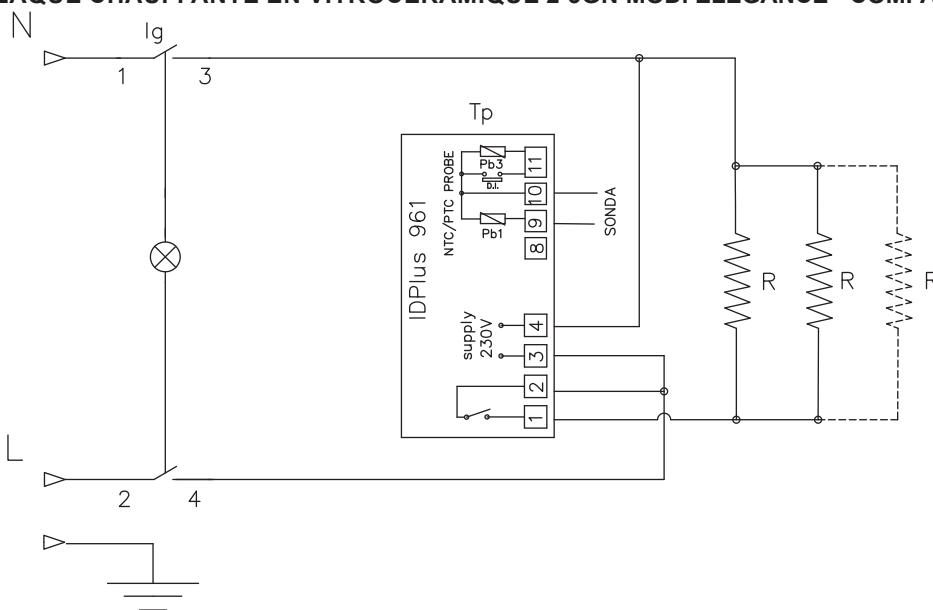
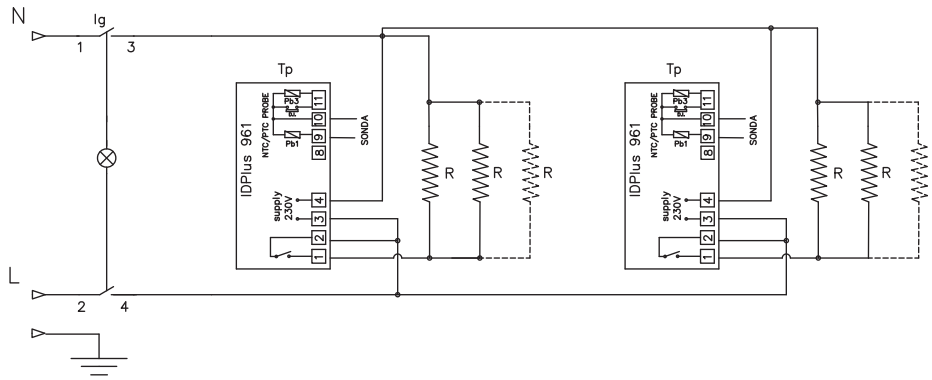

Fig. 3: SCHEMA ELETTRICO – WIRING DIAGRAMS – SCHALTPLAN – SCHEMA ELECTRIQUES

## PIANO RISCALDANTE IN VETROCERAMICA 2-3GN MOD. ELEGANCE - COMPACT / GLASS-CERAMIC HOTPLATE 2-3GN MOD. ELEGANCE - COMPACT / GLAS-KERAMIK WARMHALTEPLATTE 2-3GN MOD. ELEGANCE - COMPACT / PLAQUE CHAUFFANTE EN VITROCÉRAMIQUE 2-3GN MOD. ELEGANCE - COMPACT



**PIANO RISCALDANTE IN VETROCERAMICA 4-5GN MOD. ELEGANCE - COMPACT / GLASS-CERAMIC HOTPLATE 4-5GN MOD. ELEGANCE - COMPACT / GLAS-KERAMIK WARMHALTEPLATTE 4-5GN MOD. ELEGANCE - COMPACT / PLAQUE CHAUFFANTE EN VITROCÉRAMIQUE 4-5GN MOD. ELEGANCE - COMPACT**



**PIANO RISCALDANTE IN VETROCERAMICA 2GN MOD. ELEGANCE - COMPACT (CON TERMOREGOLATORE MECCANICO) / GLASS-CERAMIC HOTPLATE 2GN MOD. ELEGANCE - COMPACT (WITH MECHANICAL THERMOREGULATOR) / GLAS-KERAMIK WARMHALTEPLATTE 2GN MOD. ELEGANCE - COMPACT (MIT MECHANISCHEM THERMOEGULATOR) / PLAQUE CHAUFFANTE EN VITROCÉRAMIQUE 2GN MOD. ELEGANCE - COMPACT (AVEC THERMORÉGULATEUR MÉCANIQUE)**

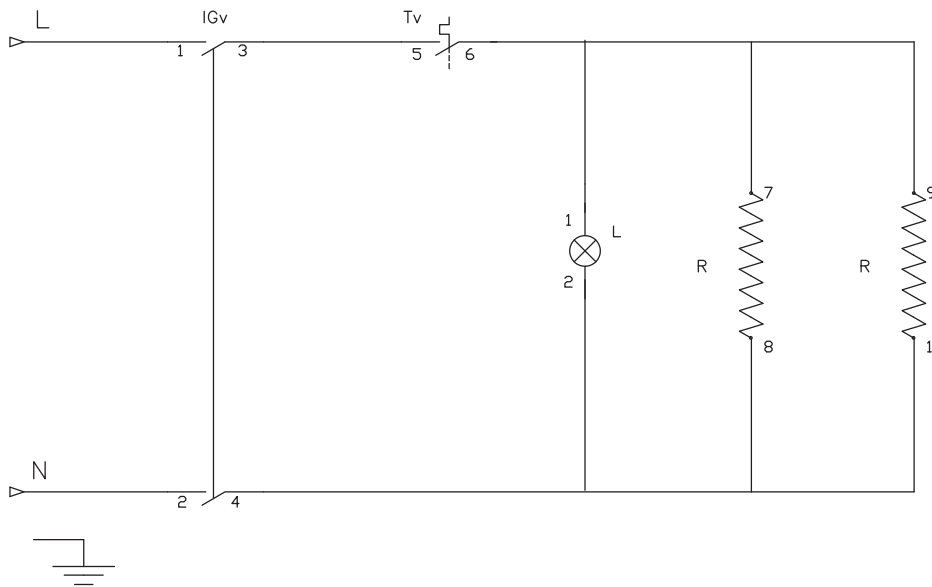

**PIANO RISCALDANTE IN VETROCERAMICA 3GN MOD. ELEGANCE - COMPACT (CON TERMOREGOLATORE MECCANICO) / GLASS-CERAMIC HOTPLATE 3GN MOD. ELEGANCE - COMPACT (WITH MECHANICAL THERMOREGULATOR) / GLAS-KERAMIK WARMHALTEPLATTE 3GN MOD. ELEGANCE - COMPACT (MIT MECHANISCHEM THERMOEGULATOR) / PLAQUE CHAUFFANTE EN VITROCÉRAMIQUE 3GN MOD. ELEGANCE - COMPACT (AVEC THERMORÉGULATEUR MÉCANIQUE)**

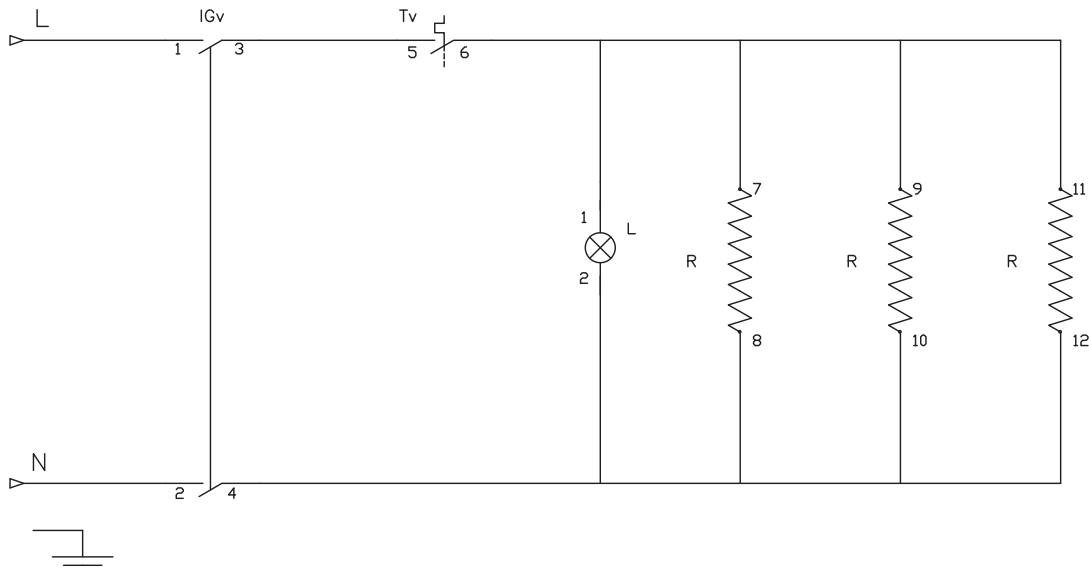

**PIANO RISCALDANTE IN VETROCERAMICA 4GN MOD. ELEGANCE - COMPACT (CON TERMOREGOLATORE MECCANICO)**  
**GLASS-CERAMIC HOTPLATE 4GN MOD. ELEGANCE - COMPACT (WITH MECHANICAL THERMOREGULATOR)**  
**GLAS-KERAMIK WARMHALTEPLATTE 4GN MOD. ELEGANCE - COMPACT (MIT MECHANISCHEM THERMOEGULATOR)**  
**PLAQUE CHAUFFANTE EN VITROCÉRAMIQUE 4GN MOD. ELEGANCE - COMPACT (AVEC THERMORÉGULATEUR MÉCANIQUE)**

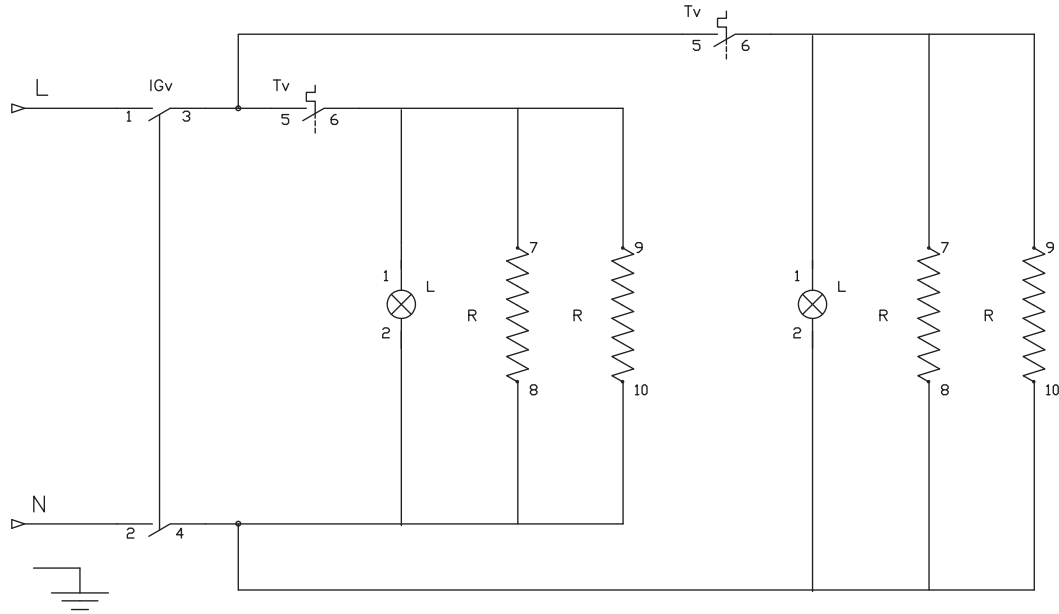

**PIANO RISCALDANTE IN VETROCERAMICA 5GN MOD. ELEGANCE - COMPACT (CON TERMOREGOLATORE MECCANICO)**  
**GLASS-CERAMIC HOTPLATE 5GN MOD. ELEGANCE - COMPACT (WITH MECHANICAL THERMOREGULATOR)**  
**GLAS-KERAMIK WARMHALTEPLATTE 5GN MOD. ELEGANCE - COMPACT (MIT MECHANISCHEM THERMOEGULATOR)**  
**PLAQUE CHAUFFANTE EN VITROCÉRAMIQUE 5GN MOD. ELEGANCE - COMPACT (AVEC THERMORÉGULATEUR MÉCANIQUE)**

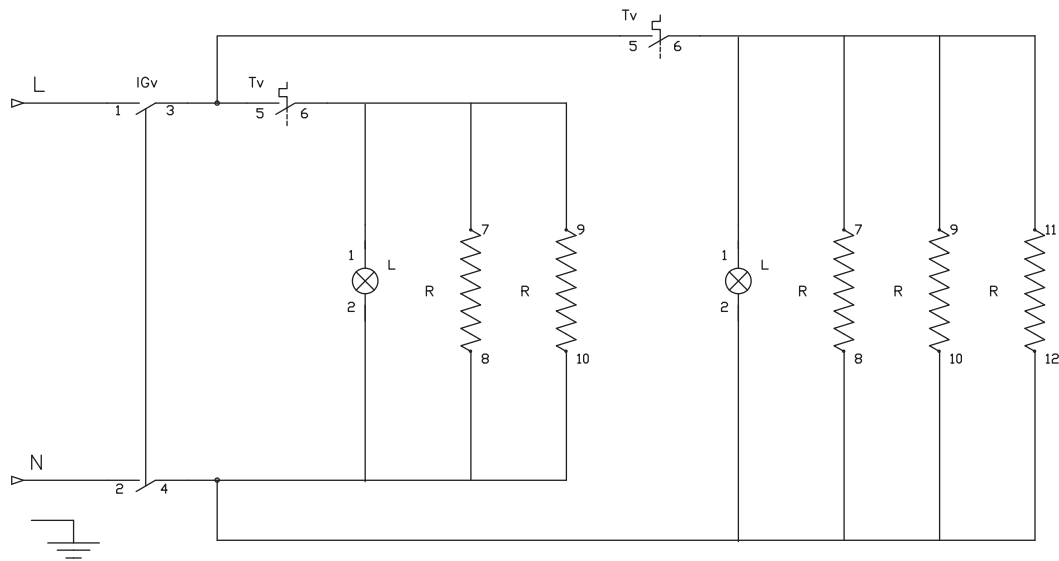

<b>Ig / IGv</b>	<b>INTERRUTTORE GENERALE - MASTER SWITCH - SCHALTER ALLGEMEINE KÜHLUNG - INTERRUPTEUR GENERALE</b>
<b>Tp / Tv</b>	<b>TERMOSTATO REGOLAZIONE PIASTRE - HOTPLATE REGULATOR THERMOSTAT - THERMOSTAT EINSTELLUNG PLATTEN - THERMOSTAT REGLAGE PLAQUES</b>
<b>R</b>	<b>RESISTENZA RISCALDANTE - HEATING ELEMENT - HEIZKÖRPER - RESISTANCE CHAUFFANTE</b>
<b>L</b>	<b>LAMPADA SPIA - INDICATOR LIGHT - KONTROLLLAMPE - VOYANT</b>

## 11.1 ELEGANCE

**Caratteristiche tecniche pinano riscaldante in vetroceramica – Technical features glass-ceramic hotplate – Technische merkmale Glas-Keramik Warmhalteplatte – Caracteristiques techniques plaque chauffante en vitrocéramique**

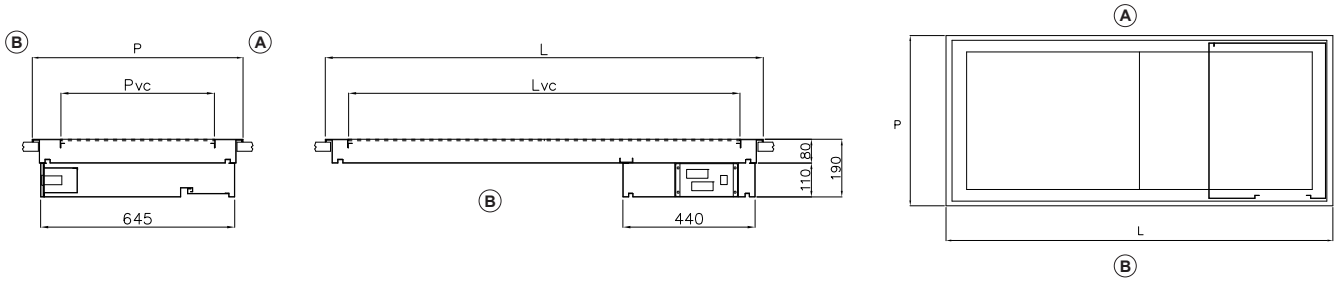

A – lato cliente - customer side - Kundenseite - côté client

B – lato operatore - operator side – Bedienerseite - côté service

**Tab. 1**

	<b>2GN</b>	<b>3GN</b>	<b>4GN</b>	<b>5GN</b>
Dimensioni esterne [mm] LxP <i>External dimensions - Aussenmasse - Dimensions externes</i>	800x700	1125x700	1455x700	1780x700
Dimensioni piano [mm] LpxPpxHp <i>Top dimensions - Plattenmasse - Dimensions plan</i>	650x510	960x510	2 x 650x510 *	650x510 + 960x510 *
Temperatura max [°C] <i>Max temperature - Temperatur Max - Température max</i>	+120	+120	+120	+120
Potenza totale (Kw) <i>Total power - Leistungsaufnahme - Puissance totale</i>	1,2	1,8	2,4	3
Tensione alimentazione (50Hz) <i>Supply voltage - Versorgungsspannung - Tension d'alimentation</i>	230V 1F+N	230V 1F+N	230V 1F+N	230V 1F+N

\* Regolazione indipendente della temperatura per ciascuna piastra - Independent temperature adjustment for each plate - Unabhängige Temperatureinstellung für jede Platte  
- Régulation de température indépendante pour chaque plaque

## 11.2 COMPACT

**Caratteristiche tecniche pinano riscaldante in vetroceramica – Technical features glass-ceramic hotplate – Technische merkmale Glas-Keramik Warmhalteplatte – Caracteristiques techniques plaque chauffante en vitrocéramique**

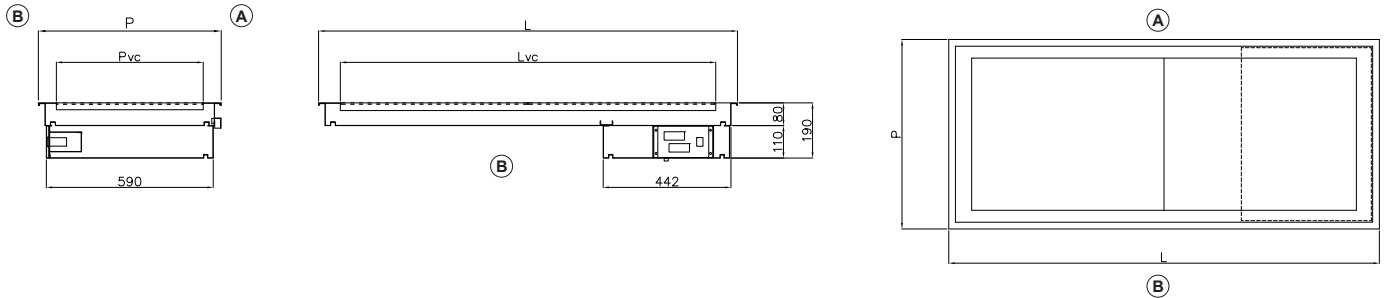

A – lato cliente - customer side - Kundenseite - côté client

B – lato operatore - operator side – Bedienerseite - côté service

**Tab. 1**

	<b>2GN</b>	<b>3GN</b>	<b>4GN</b>	<b>5GN</b>
Dimensioni esterne [mm] LxP <i>External dimensions - Aussenmasse - Dimensions externes</i>	805x635	1135x635	1455x635	1780x635
Dimensioni piano [mm] LpxPpxHp <i>Top dimensions - Plattenmasse - Dimensions plan</i>	650x510	960x510	2 x 650x510 *	650x510 + 960x510 *
Temperatura max [°C] <i>Max temperature - Temperatur Max - Température max</i>	1,2	1,8	2,4	3
Potenza totale (Kw) <i>Total power - Leistungsaufnahme - Puissance totale</i>	120	120	120	120
Tensione alimentazione (50Hz) <i>Supply voltage - Versorgungsspannung - Tension d'alimentation</i>	230V 1F+N	230V 1F+N	230V 1F+N	230V 1F+N

\* Regolazione indipendente della temperatura per ciascuna piastra - Independent temperature adjustment for each plate - Unabhängige Temperatureinstellung für jede Platte  
- Régulation de température indépendante pour chaque plaque