



MOD : AE1N/PL2

Production code : AEF7X2511-DM

09/2025

CIRCUITO FRIGORIFERO PER ARMADI REFRIGERATI PREDISPOSTI
 REFRIGERATING CYCLE DIAGRAM FOR REMOTE REFRIGERATING COUNTERS
 SCHEMA DU CYCLE DE REFRIGERATION - ARMOIRES REFRIGEREES SANS COMPRESSEUR
 KÜHLSCHHEMA FÜR KÜHLSCHRÄNKE OHNE AGGREGAT
 CIRCUITO DE REFRIGERAÇÃO REMOTO PARA REFRIGERADORES PROFISSIONAIS

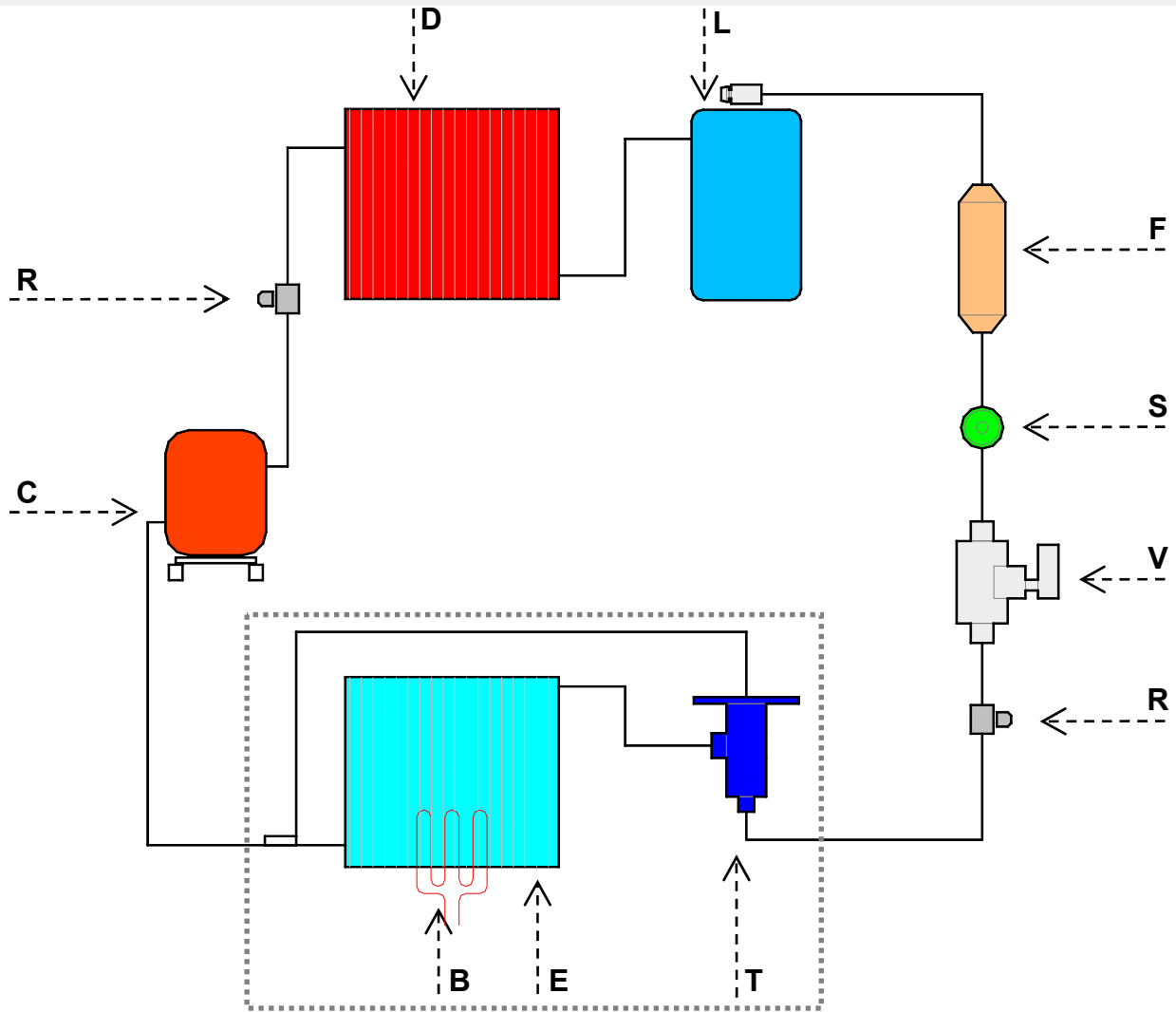

	IT	GB	FR	DE	PT
C	Compressore	Compressor	Compresseur	Kompressor	Compressor
R	Rubinetto	Cock	Robinet	Hahn	Conexão
D	Condensatore	Condenser	Condenseur	Kondensator	Condensador
L	Ricevitore di liquido	Liquid receiver	Collecteur de liquide	Flüssigkeitsempfänger	Receptor de liquido
F	Filtro deidratatore	Dehydrating filter	Filtre déshydrater	Feuchtigkeitseutzugsfilter	Capilar
S	Spia liquido	Liquid pilot light	Témoin de liquide	Kontrolleuchte Flüssigkeit	Visor de liquido
V	Valvola solenoide	Solenoid valve	Vanne solénoïde	Solenoidventilator	Válvula Solenóide
T	Valvola d'espansione	Expansion valve	Vanne d'expansion	Ausdehnungsventil	Válvula de expansão
E	Evaporatore	Evaporator-cooler unit	Evaporateur	Verdampfungseinheit	Evaporador
B	Resistenza Sbrinamento	Defrosting resistance	Resistance dégivrages	Abtauungswiderstand	Resistência Degelo

CIRCUITO FRIGORIFERO PER ARMADI REFRIGERATI PREDISPOSTI
 REFRIGERATING CYCLE DIAGRAM FOR REMOTE REFRIGERATING COUNTERS
 SCHEMA DU CYCLE DE REFRIGERATION - ARMOIRES REFRIGEREES SANS COMPRESSEUR
 KÜHLSCHHEMA FÜR KÜHLSCHRÄNKE OHNE AGGREGAT
 CIRCUITO DE REFRIGERAÇÃO REMOTO PARA REFRIGERADORES PROFISSIONAIS

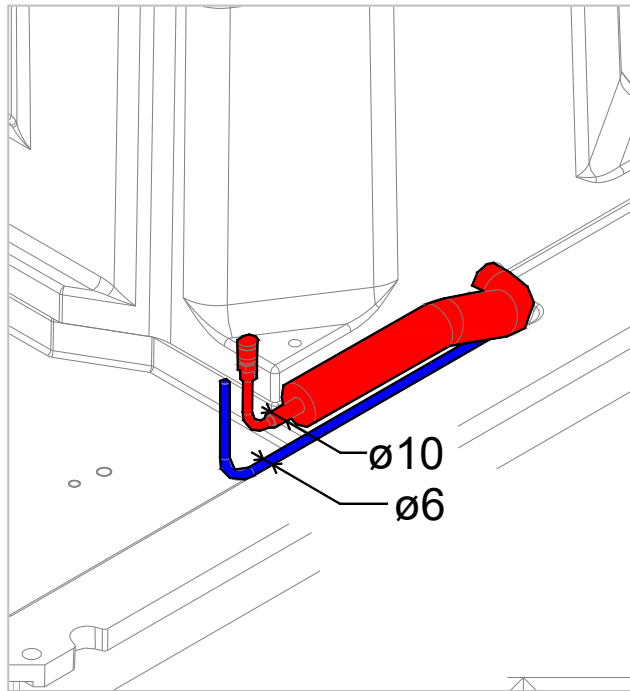

LINEA ASPIRAZIONE

SUCTION LINE
 TUBE ASPIRATION
 BSAUGSROHR
 LINHA DE ASPIRAÇÃO

~ 2 mt

> 0.5 mt

> 0.5 mt

> 2%...3%

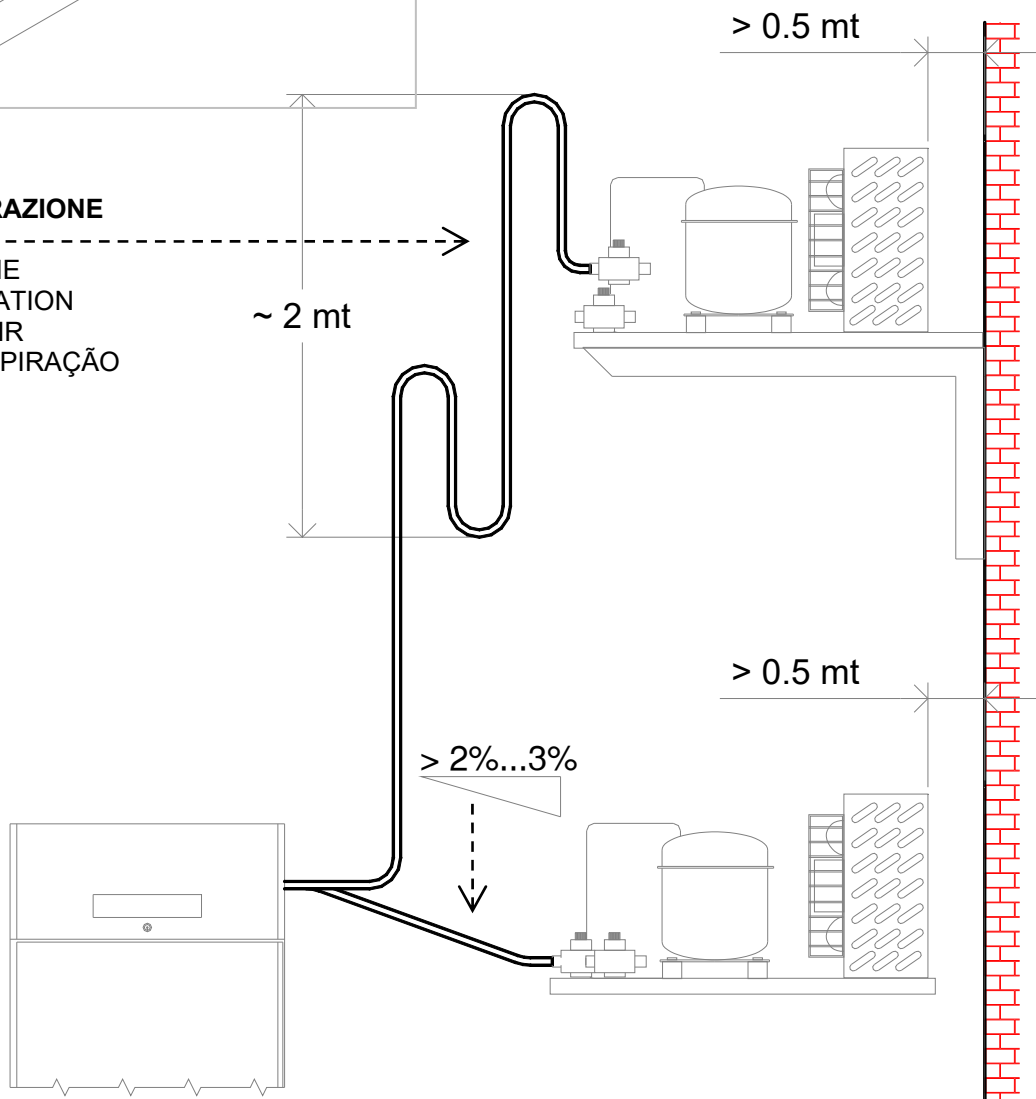

COLLEGAMENTI ELETTRICI - ELECTRICAL CONNECTION
BRANCHEMENT ELECTRIQUE - ELEKTROANSCHLUSS - CONEXÃO ELÉTRICA

	IT	GB	FR	DE	PT
C	Compressore	Compressor	Compresseur	Kompressor	Compressor
F	Fusibile (solo predisposti)	Fuse (remote refrig. unit models only)	Fusible (seulement mod. sans groupe logé)	Sicherung (nur bei Zentralkühlungs- Modellen)	Fusível (somente remotos)
L1...2	Luce cruscotto	Control panel lighting	Eclairage façade	Bedienfeld-Beleuchtung	Luz do painel
LED1..2	Luce cella (solo porte vetro)	Refrigerator interior lighting (glass door models only)	Eclairage intérieur (seulement mod. portes vitrées)	Raumbeleuchtung (nur bei Modellen mit Glastüren)	Luz câmara (somente portas de vidro)
MP1...2	Microporta	Door microswitch	Microinterrupteur porte	Türschalter	Micro da porta
PT	Protezione termica (solo sbrinamento elettrico)	Thermal protection (electric defrost models only)	Protection thermique (seulement mod. avec dég. élec.)	Übertemperatur- sicherung (nur bei Modellen mit elektrischer Abtauung)	Proteção térmica (somente degelo elétrico)
AL1...2 RE1...2	Reattore LED Power (solo porte vetro)	Ballast LED Power (glass door models only)	Ballast LED Power (seulement mod. portes vitrées)	Vorschaltgerät LED Power (nur bei Modellen mit Glastüren)	Reator LED Power (somente portas de vidro)
RSB	Resistenza sbrinamento (solo sbrinamento elettrico)	Defrost heater (only electr. defrost)	Résistance de dégivrage (seulement mod. avec dég. élec.)	Abtauheizung (nur bei Modellen mit elektrischer Abtauung)	Resistência degelo
RSP1...2	Resistenza cornice porta (solo porte vetro BT)	Resistance door frame (only BT glass door)	Cadre de la porte de résistance (seulement portes vitrées BT)	Widerstand Türrahmen (nur bei Modellen mit Glastüren)	(somente degelo elétrico)
RSC	Resistenza scarico (solo statici)	Drain heater (static refrigeration system models only)	Résistance d'évacuation (seulement mod. statiques)	Ablaufheizung (nur bei Modellen mit statischer Kühlung)	Resistência quadro da porta (somente portas de vidro BT)
RST1..2	Resistenza stipite (solo mod. BT)	Door frame heater (LT mod. only)	Cordon chauffant (seulement mod. BT)	Türrahmenheizung (nur bei TK-Modellen)	Resistencia do quadro da porta (somente BT)
S	Starter (solo mod. porte vetro)	Starter (glass door models only)	Starter (seulement mod. portes vitrées)	Starter (nur bei Modellen mit Glastüren)	Starter (somente portas de vidro)
VC1...2	Ventilatore condensatore	Condenser fan	Ventilateur condenseur	Kondensatorventilator	Ventilador do condensador (somente ventilados)
VE VA	Ventilatore evaporatore (solo mod. ventilati)	Evaporator fan (models with forced-air refr. system only)	Ventilateur évaporateur (seulement mod. ventilés)	Verdampferventilator (nur bei Modellen mit Umluftkühlung)	Vetilador do evaporador (somente degelo com gás quente)
VS	Valvola gas caldo (solo sbrinamento gas caldo)	Hot gas valve (hot gas defrost models only)	Vanne gaz chaud (seulement mod. dég. par gaz chaud)	Heißgas-Ventil (nur bei Modellen mit Heißgas- Abtauung)	Válvula gás quente (somente degelo com gás quente)
VL	Valvola Liquido	Liquid valve	Vanne liquid	Flüssigkeitsventil	válvula de líquido
SC	Sonda cella	Cell probe	Sonde cellule	Zellenfühler	Sonda câmara
SE	Sonda evaporatore	Evaporator probe	Sonde évaporateur	Verdampferfühler	sonda evaporador
S3	Sonda condensatore	Condenser probe	Sonde condensateur	Kerntemperaturfühler	Sonda condensador

44538-00

GLASS DOOR

SCHEMA ELETTRICO - ELECTRIC DIAGRAM – SCHALTBILD
 SCHÉMA ÉLECTRIQUE - ESQUEMA ELÉCTRICO - ESQUEMA ELÉTRICO

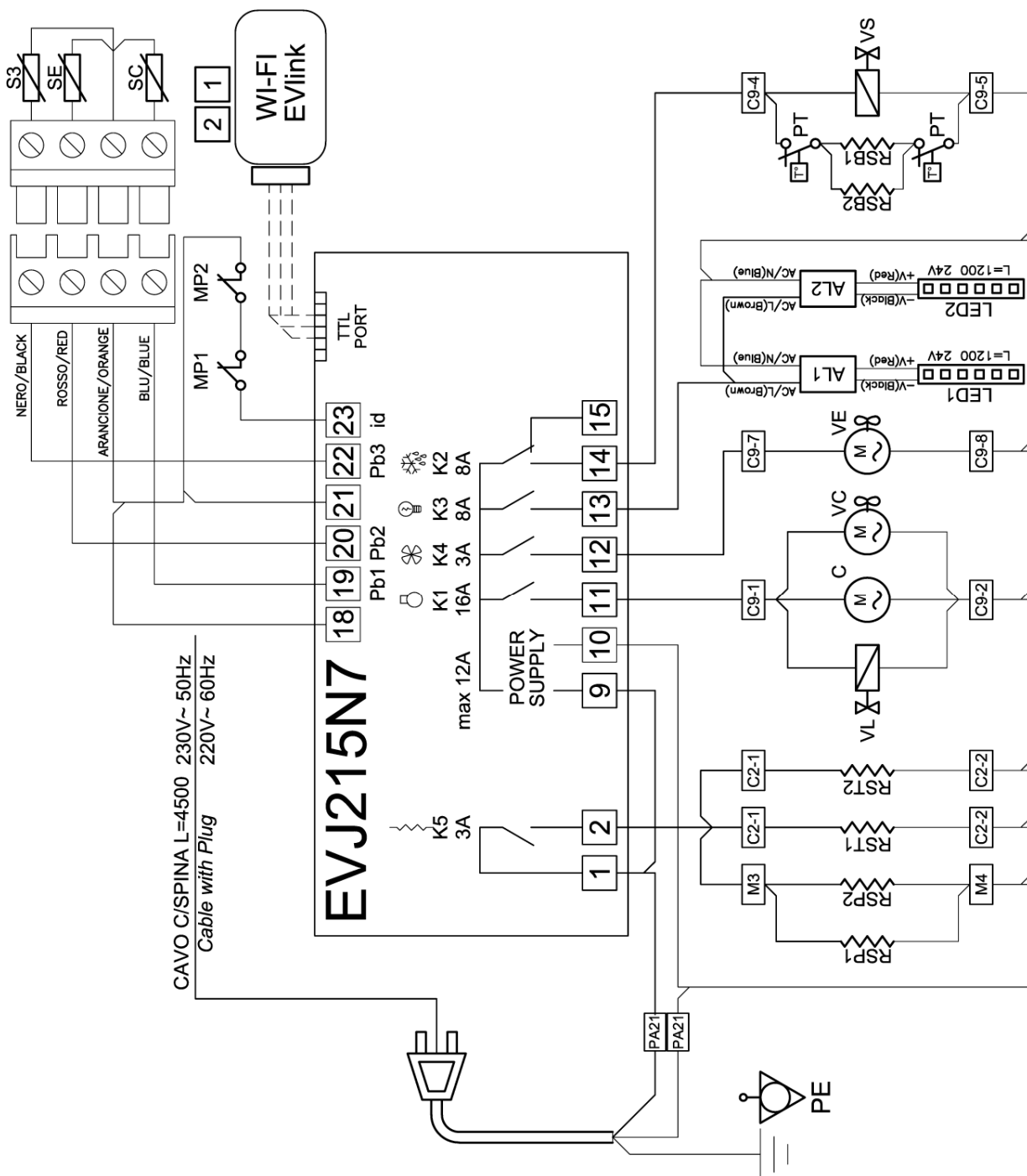

44546-00

REMOTE VERSION

SCHEMA ELETTRICO - ELECTRIC DIAGRAM – SCHALTBILD
 SCHEMA ÉLECTRIQUE - ESQUEMA ELÉCTRICO - ESQUEMA ELÉTRICO

