



MOD : CUB160/65W

Production code : 30724S11QZ1856 - CB 1565W HC B-QUBE

01/2026

SCHEMA ELETTRICO / WIRING DIAGRAM / ESQUEMA ELECTRICO

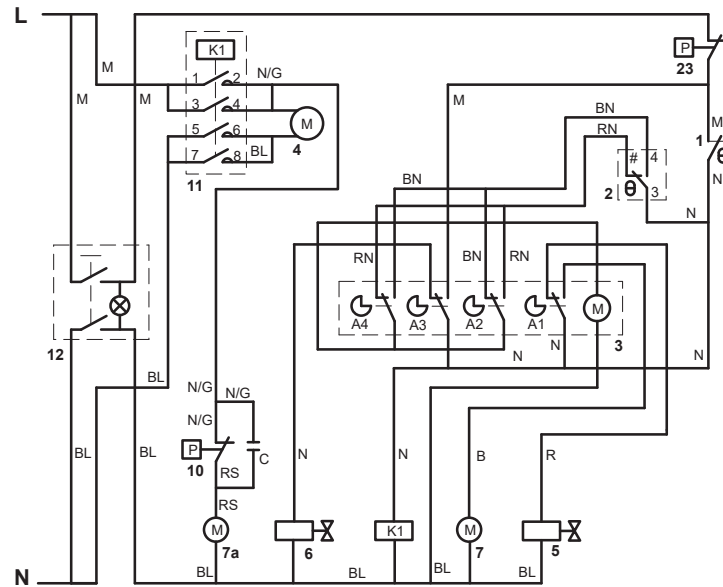

VERSIONE AD ARIA / AIR COOLED

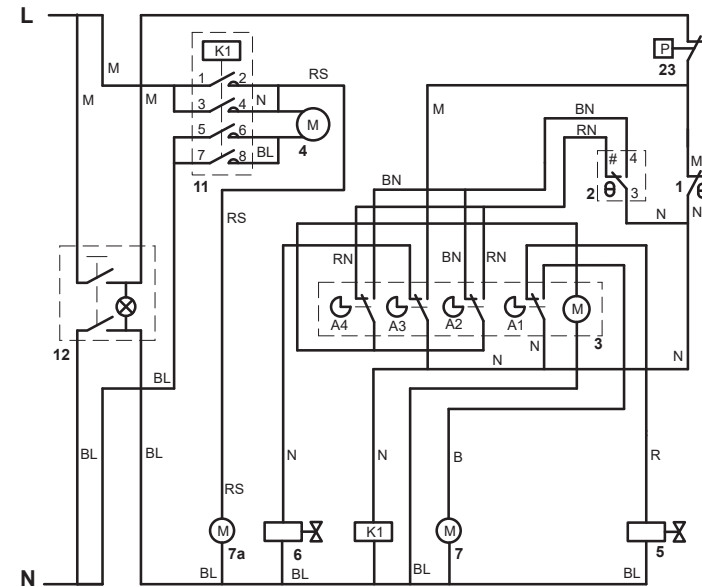

VERSIONE AD ACQUA / WATER COOLED

1. TERMOSTATO CONTENITORE BIN THERMOSTAT TERMOSTATO CONTENEDOR	5. ELETTROVALVOLA GAS CALDO HOT GAS VALVE ELECTROVALVULA GAS CALIENTE	10. PRESSOSTATO PRESSURE SWITCH PRESOSTATO	B = BIANCO / WHITE / BLANCO BL = BLU / BLUE / AZUL BN = BIANCO-NERO / WHITE-BLACK / BLANCO-NEGRO G = GRIGIO / GREY / GRIS M = MARRONE / BROWN / MARRON N = NERO / BLACK / NEGRO R = ROSSO / RED / ROJO RN = ROSSO-NERO / RED-BLACK / ROJO-NEGRO RS = ROSA / PINK / ROSA
2.* TERMOSTATO EVAPORATORE EVAPORATOR THERMOSTAT TERMOSTATO EVAPORADOR	6. ELETTROVALVOLA INGRESSO ACQUA PER EVAPORATORE WATER INLET VALVE FOR EVAPORATOR VALVULA INGRESSO AGUA POR EVAPORADOR	11. TELERUTTORE CONTACTOR CONTACTOR	
3. TEMPORIZZATORE TIMER TIMER	7. POMPA PUMP BOMBA	12. INTERRUPTORE LUMINOSO SWITCH ON-OFF (GREEN LIGHT) INTERRUPTOR ON-OFF	
4. COMPRESSORE COMPRESSOR COMPRESOR	7a. MOTOVENTILATORE FAN MOTOR MOTOR VENTILADOR	23. PRESSOSTATO DI SICUREZZA SAFETY PRESSURE SWITCH PRESOSTATO DE SEGURIDAD	
* RANCO K22 : # = 2 DANFOSS 077B : # = 6			