



MOD : PEB150/50W

Production code : TB 1405W HC

01/2026

PEB150/50W

Ice Pebbles



Produttore di ghiaccio con contenitore incorporato - Sistema a trafila
Produzione giornaliera fino a 158 kg

Hotel	██████████
Ristoranti	██████████
Fast food	██████████
Bar	██████████
Discoteche	██████████
Mercati ittici	██████████
Supermercati	██████████
Medicale & SPA	██████████
Industrie	██████████

► Position n°



► Features & Plus

- Ghiaccio a tronchetti 91% dry
- 1L (acqua) = 1kg (ghiaccio) - solo A
- Carrozzeria AISI 304 Scotch Brite
- Classe Tropicale + 43° C
- Piedini acciaio inox regolabili
- Filtro Aria smontabile e pulibile
- Evaporatore in Acciaio AISI 304
- Condensazione aria o acqua
- Superfici interne arrotondate per pulizia
- Isolamento contenitore HCFC-Free
- Bacinella acqua sigillata antipolvere
- RoHS Free
- Sportello isolato con apertura a scomparsa
- Funzionamento elettromeccanico
- Interruttore ON/OFF
- Carico automatico dell'acqua
- Voltaggio standard e voltaggi speciali
- HFC Free



Carrozzeria AISI 304 Scotch Brite



Filtro Aria smontabile e pulibile



Evaporatore in Acciaio AISI 304



Bacinella acqua sigillata antipolvere



Sportello isolato con apertura a scomparsa

► Dimensione disponibile

Disegno a scopo esclusivamente indicativo

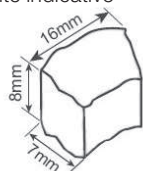

► Prod. 24h

T. aria	T. acqua		kg	lbs	
	10° C	50° F			7° C
21° C	70° F	15° C	60° F	146	322

► Certificazioni disponibili per questo modello



Diamond



Ice Pebbles

PEB150/50W

Produttore di ghiaccio con contenitore incorporato - Sistema a trafilata
Produzione giornaliera fino a 158 kg

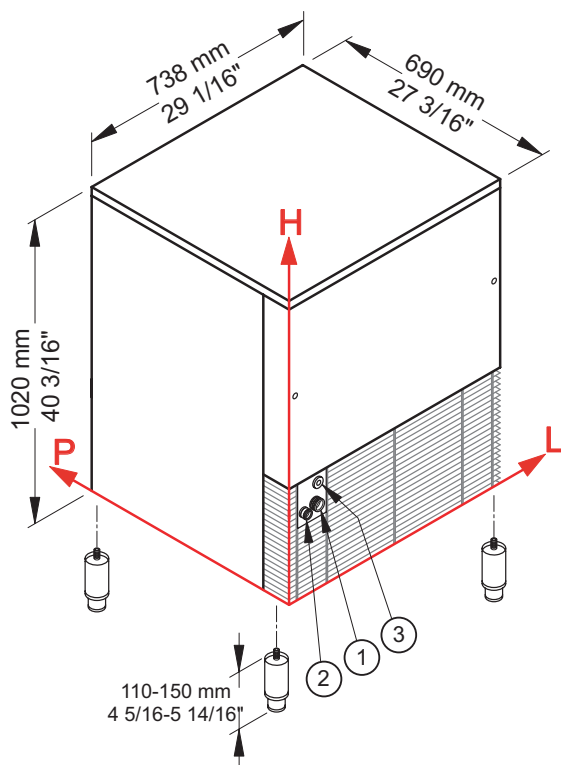

► Condizioni d'installazione

- Installazione: **Interna**

	Min	Max
Temperatura ambiente	+10° C / +50° F	+43° C / 110° F
Temperatura acqua	+3° C / +37° F	+32° C / +90° F
Voltaggio	-10%	+10%
Pres. acqua in ingresso	1bar (14 psi)	6bar (84 psi)

► Performance

	Temperatura acqua	Temperatura acqua				
		7° C	45° F	15° C	60° F	21° C
Temperatura aria	10° C	158 kg				
	50° F	348 lbs				
	21° C		146 kg			
	70° F			322 lbs		
	32° C				130 kg	
	90° F					287 lbs

► Connessioni

Le misure sono riferite all'angolo del retro in basso a sinistra (L-H-Ø)

- ① Ingresso acqua: 104 mm / 4 2/16" - 247 mm / 9 12/16" - 3/4" ② Scarico acqua: 53 mm / 2 1/16" - 240 mm / 9 7/16" - 24 mm / 15/16"
③ Connessione elettrica: 92 mm / 3 10/16" - 319 mm / 12 9/16"

► Dati tecnici

Produzione in 24h	146 kg / 322 lbs	Consumo d'acqua	A: 1 l/kg - 12,0 gal/100 lbs
Capacità contenitore, fino a	50 kg / 110 lbs		W: 9 l/kg - 107,8 gal/100 lbs
Condensazione	A - W	Dimensioni (L-P-H mm)	738 - 690 - 1020
Dimensioni indicative pebble	8 x 16 x 7	(L-P-H in)	29 1/16 - 27 3/16 - 40 3/16
Refrigerante	R290	Dimensioni imballo (L-P-H mm)	780 - 735 - 1185
Voltaggio standard	220-240 V ~ 50 Hz	(L-P-H in)	30 11/16 - 28 15/16 - 46 10/16
Potenza media assorbita	720 W	Peso netto	94 kg / 207 lbs
Fusibile	10 A	Peso lordo	105 kg / 231 lbs
Consumo elettrico	13 kWh/100kg	Finitura	Acciaio inox 18/8, scotch brite

Tutti i dati tecnici sono da considerarsi validi alle seguenti condizioni:

Temperatura ambiente +21° C

Temperatura acqua +15° C

Consumo elettrico a +32° C (Voltaggio standard)

Potenza media assorbita a +43° C (Voltaggio standard)

I modelli ed i dati riportati possono essere soggetti a modifiche senza alcun preavviso