



MOD : SGBT/20S

Production code : 228708

01/2026

GAS OVENS

Electrical Documentation

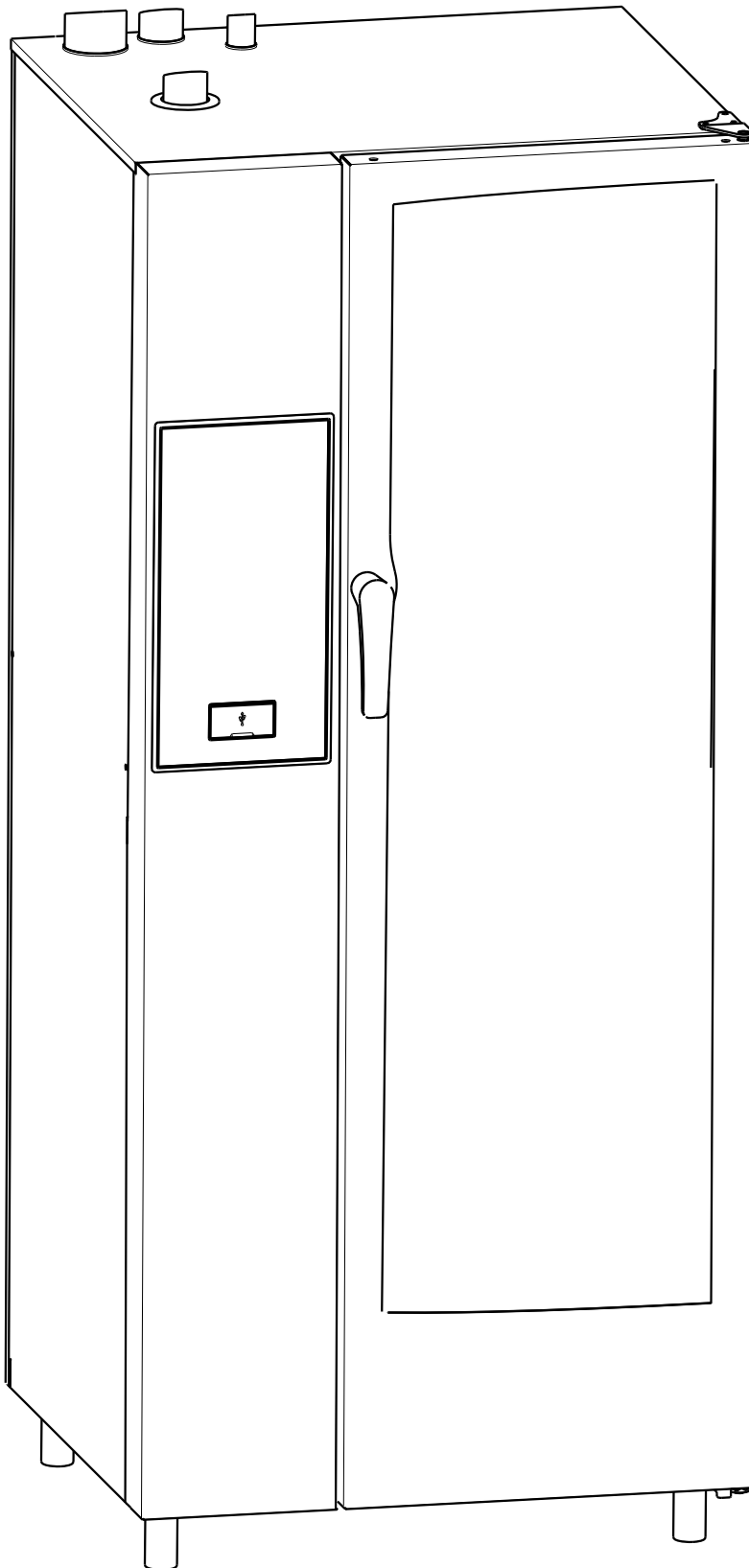

20 1/1
&
20 2/1

MAIN BOARD ACU

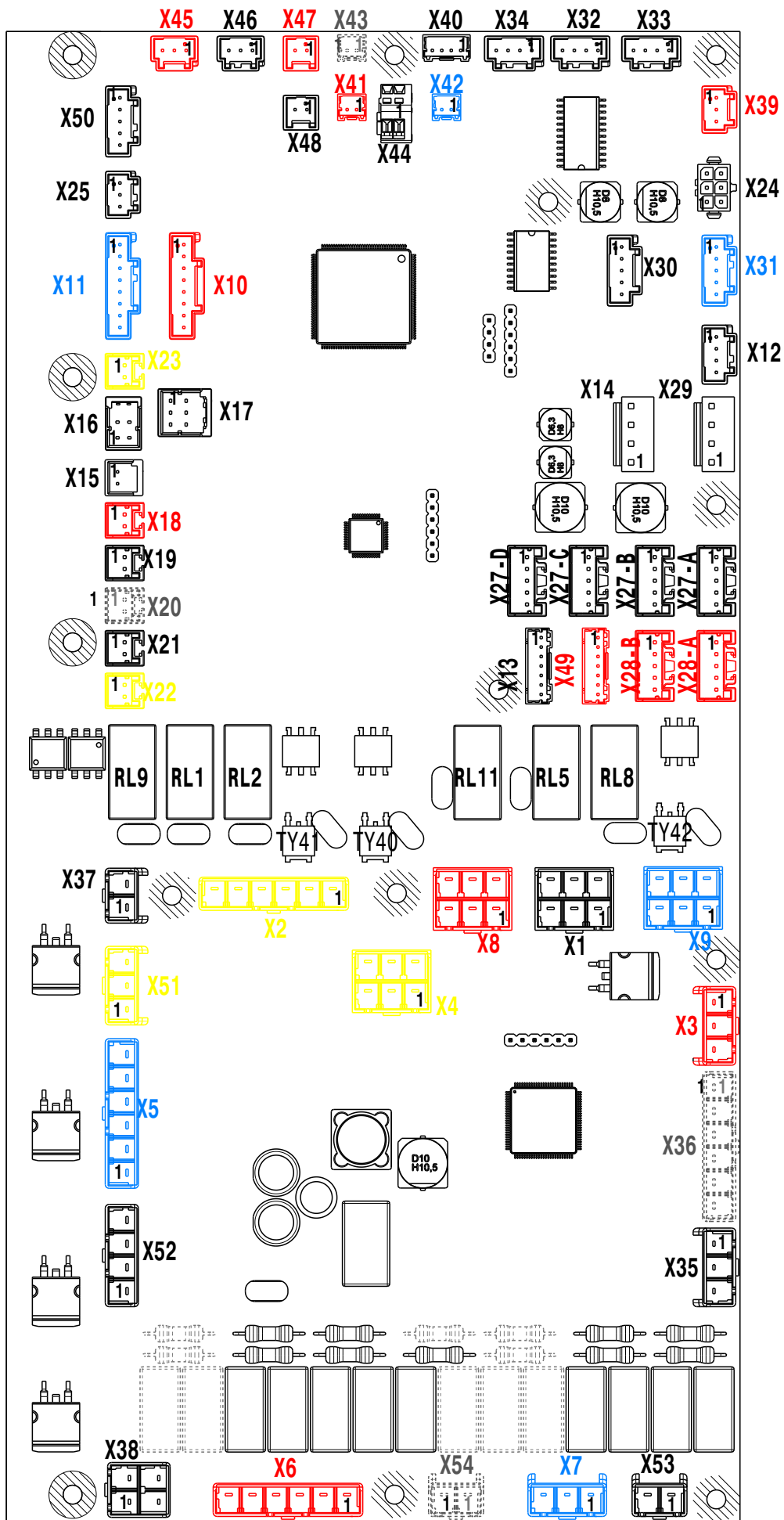

ACU LEGENDA

Ref.	Group	Pin	Direct.	Function
X1	Power Supply	1	IN	L Power Supply
		2	IN	N Power Supply
		3	IN	L Power Supply
		4	IN	N Power Supply
		5	IN	SW-OFF Auto switch off
		6	OUT	
X2	Water Service	1	OUT	EV1 Instant steam solenoid valve
		2	OUT	EV2 Quenching solenoid valve
		3	OUT	EV4 Spray unit solenoid valve
		4	OUT	BV3 Cavity drain ball valve OPEN
		5	OUT	BV3 Cavity drain ball valve CLOSE
		6	OUT	N
X3	Clean. Syst. Basic	1	OUT	EV7 Cleaning water fill solenoid valve
		2	OUT	M8 Cleaning pump
		3	OUT	N
X4	Cleaning System Drawer Rinse	1	OUT	EV11 Drawer fill solenoid valve
		2	OUT	EV12 Drawer drain solenoid valve
		3	OUT	
		4	OUT	
		5	OUT	
		6	OUT	N
X5	Boiler Fill & Clean	1	OUT	EV5 Boiler fill solenoid valve
		2	OUT	
		3	OUT	BV6 Boiler drain ball valve OPEN
		4	OUT	BV6 Boiler drain ball valve CLOSE
		5	OUT	
		6	OUT	N
X6	Sensing	1	IN	TSC Cavity safety thermostat
		2	IN	BBC1 Cavity gas blower burner UP
		3	IN	BBC2 Cavity gas blower burner DOWN
		4	IN	HV14 Motor drive fuse UP
		5	IN	HV15 Motor drive fuse DOWN
		6	IN	
X7	Sensing	1	IN	TSB Boiler safety thermostat
		2	IN	BBB1 Boiler gas blower burner
		3	IN	
X8	Cavity GAS burner	1	OUT	N
		2	OUT	FCU Cavity flame control unit reset UP
		3	OUT	FCU Cavity flame control unit reset DOWN
		4	IN	FCU Cavity flame control units power supply IN
		5	OUT	FCU Cavity flame control unit power supply UP
		6	OUT	FCU Cavity flame control unit power supply DOWN
X9	Boiler GAS burner	1	OUT	N
		2	OUT	FBU Boiler flame control unit reset
		3	OUT	
		4	IN	FBU Boiler flame control unit power supply IN
		5	OUT	FBU Boiler flame control unit power supply OUT
		6	OUT	
X10	Cavity GAS blower	1	OUT	VTCU Cavity blower control Power supply
		2	IN	VTCU Cavity blower control Tachometer UP
		3	IN	
		4	OUT	VTCU Cavity blower control Speed UP
		5	IN	VTCU Cavity blower control Tachometer DOWN
		6	IN	
		7	OUT	VTCU Cavity blower control Speed DOWN
		8	OUT	VTCU Boiler blower control GND
X11	Boiler GAS blower	1	OUT	VTBU Boiler blower control Power supply
		2	IN	VTBU Boiler blower control Tachometer
		3	IN	
		4	OUT	VTBU Boiler blower control Speed control
		5	IN	
		6	IN	
		7	OUT	
		8	OUT	VTBU Boiler blower control GND

Ref.	Group	Pin	Direct.	Function
X12	Led	1	OUT	H1 LED lighting 1 anode
		2	IN	H1 LED lighting 1 catode
		3	IN	H2 LED lighting 2 catode
		4	OUT	H2 LED lighting 2 anode
X13			Adress	
X14	12V	1	IN	+12V dc
		2	IN	
		3	IN	0V dc
		4	IN	
X15	Food probe temperature	A1	IN	TFP 1 st point food probe temperature
		A2	IN	
X16	Food probe temperature	B1	IN	TFP 2 nd point food probe temperature
		A2	IN	TFP 3 rd point food probe temperature
X17	Food probe temperature	B2	IN	TFP 4 th point food probe temperature
		A1	IN	TFP 5 th point food probe temperature
		A2	IN	
		B2	IN	
		A3	IN	TFP 6 th point food probe temperature
		B3	IN	
X18	Temper.	1	IN	TCAV Cavity Thermocouple UP
		2	IN	
X19	Temper.	1	IN	TBOI Boiler Thermocouple
		2	IN	
X20	Temper.		-- NOT USE --	
X21	Temper.	1	IN	TCAV Cavity Thermocouple DOWN
		2	IN	
X22	Temper.	1	IN	TQS Quenching System Thermocouple
		2	IN	
X23	Temper.	1	IN	TAR Aromatizer Thermocouple
		2	IN	
X24			Lambda sensor	
X25	Boiler level	1	IN/OUT	SL Boiler safety level dection probe
		2	IN/OUT	WL Boiler working level dection probe
		3	IN	REF Boiler level detection probes reference
X27-A		IN/OUT	PMACS communication BUS	
X27-B		IN/OUT	PMACS communication BUS	
X27-C		IN/OUT	PMACS communication BUS	
X27-D		IN/OUT	PMACS communication BUS	
X28-A		IN/OUT	PMACS Recovery communication BUS	
X28-B		IN/OUT	PMACS Recovery communication BUS	
X29	24V	1	IN	+24V dc
		2	IN	
		3	IN	0V dc
		4	IN	
X30	Cavity SSR	1	OUT	KC1 Cavity 1 solid state relay UP
		2	OUT	KC2 Cavity 2 solid state relay UP
		3	OUT	KC3 Cavity 1 solid state relay DOWN
		4	OUT	KC4 Cavity 2 solid state relay DOWN
		5	OUT	0V dc
X31	Boiler SSR	1	OUT	KB1 Boiler 1 solid state relay UP
		2	OUT	KB2 Boiler 2 solid state relay UP
		3	OUT	KB3 Boiler 1 solid state relay DOWN
		4	OUT	KB4 Boiler 2 solid state relay DOWN
		5	OUT	0V dc

Ref.	Group	Pin	Direct.	Function
X32	Cooling Fan 1	1	OUT	FAN1 Cooling fan 1 power supply 24Vdc
		2	IN	FAN1 Cooling fan 1 tachometer sensor
		3	OUT	FAN1 Cooling fan 1 speed control
		4	OUT	FAN1 Cooling fan 1 power supply 0Vdc
X33	Cooling Fan 2	1	OUT	FAN2 Cooling fan 2 power supply 24Vdc
		2	IN	FAN2 Cooling fan 2 tachometer sensor
		3	OUT	FAN2 Cooling fan 2 speed control
		4	OUT	FAN2 Cooling fan 2 power supply 0Vdc
X34	Cooling Fan 3	1	OUT	FAN3 Cooling fan 3 power supply 24Vdc
		2	IN	FAN3 Cooling fan 3 tachometer sensor
		3	OUT	FAN3 Cooling fan 3 speed control
		4	OUT	FAN3 Cooling fan 3 power supply 0Vdc
X35	Vent. Valve	1	OUT	VV1 Venting valve 1 cw rotation
		2	OUT	N
		3	OUT	VV1 Venting valve 1 ccw rotation
X36			-- NOT USE --	
X37	KS	1	OUT	KS Safety contactor
		2		
X38	Smoker	1	OUT	N
		2	OUT	R1 (Smoker heating element)
		3	OUT	
		4	IN	
X39	Flow meter	1	OUT	+24V dc
		2	OUT	FM Flow meter reference
		3	IN	FM Flow meter feedback
X40	Temper.	1	OUT	NCC NTC cabinet components
		2	IN	
		3	OUT	NM8 NTC pump M8
		4	IN	
X41	Temper.	1	OUT	NHSC NTC Cavity SSR heatsink
		2	IN	
X42	Temper.	1	OUT	NHSB NTC Boiler SSR heatsink
		2	IN	
X43	Temper.		-- NOT USE --	
X44	Softner	1	OUT	SSW1 Softner interface
		2	IN	
X45	Switch	1	OUT	24V Reference
		2	IN	DS Door switch
		3	IN	AFS Air filter switch
X46	switch	1	OUT	24V Reference
		2	IN	SVV1 Venting valve CLOSE switch
		3	IN	SVV1 Venting valve OPEN switch
X47		1	OUT	24V Reference
		2	IN	SF Fat drain valve status switch
X48	Switch	1	OUT	24V Reference
		2	IN	DRS Cleaning drawer switch
X49			Recovery Adress	
X50		1	OUT	24V Reference
		2	IN	HER Hood error
		3	IN	
		4	IN	
		5	IN	
X51	Liquid Clean Syst.	1	OUT	P1 Liquid dergent pump
		2	OUT	P2 Liquid rinse pump
		3	OUT	N
X52		1	OUT	HS2 Hood speed 2
		2	OUT	HS1 Hood speed 1
		3	OUT	HON Hood ON
		4	OUT	N Neutral
X53		1	IN	PPM1 Peak power management 1
		2	IN	PPM2 Peak power management 2
X54			-- NOT USE --	

LOGIC DIAGRAM

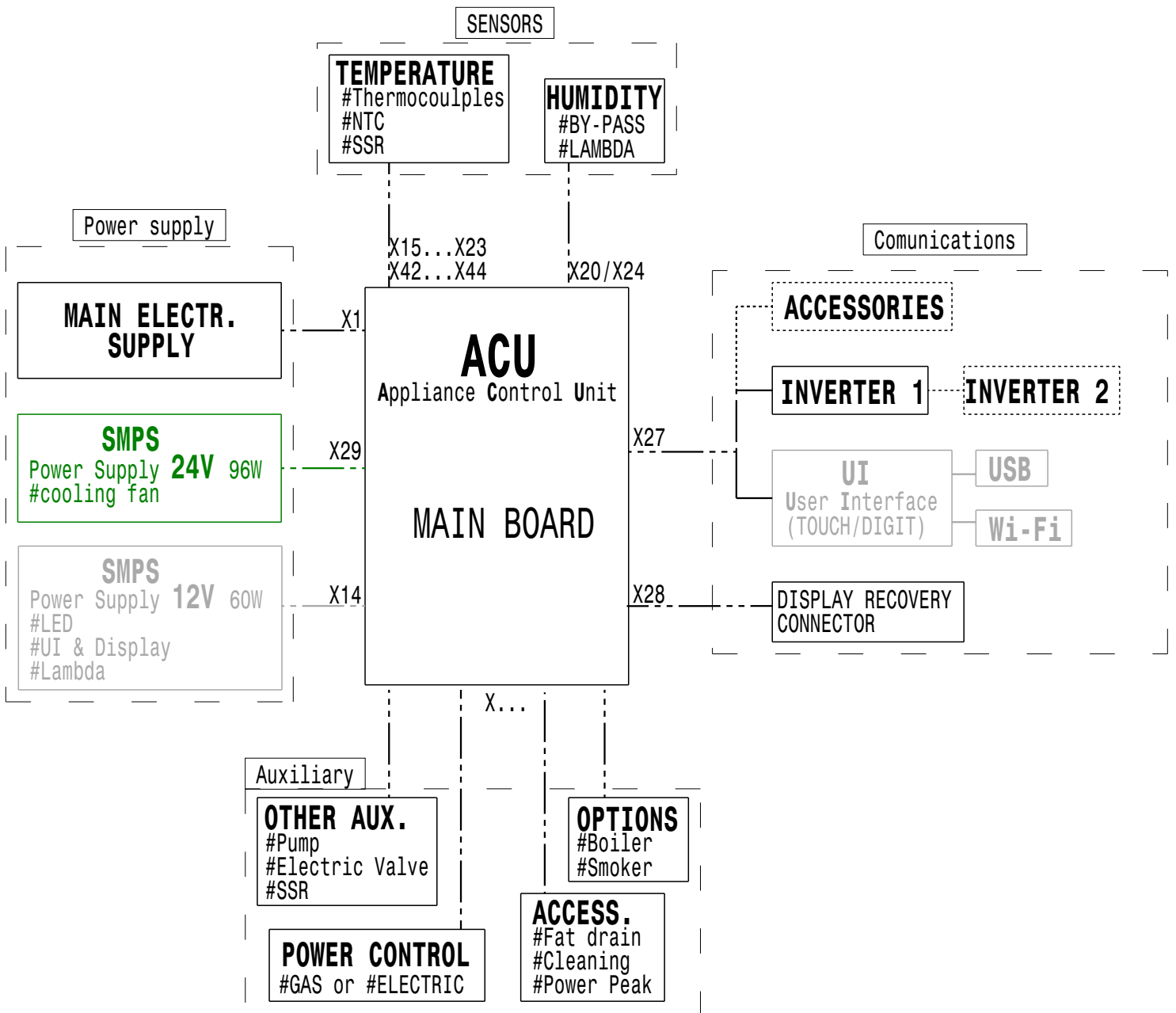

HARNES DIAGRAM

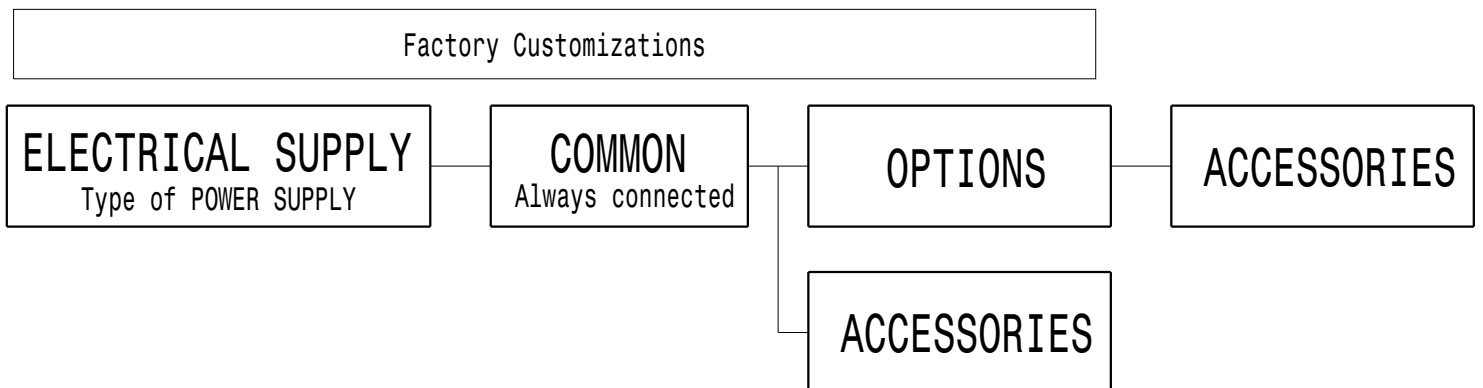

ELECTRICAL SUPPLY 220-240V - 1N - 50/60Hz **"GAS"**

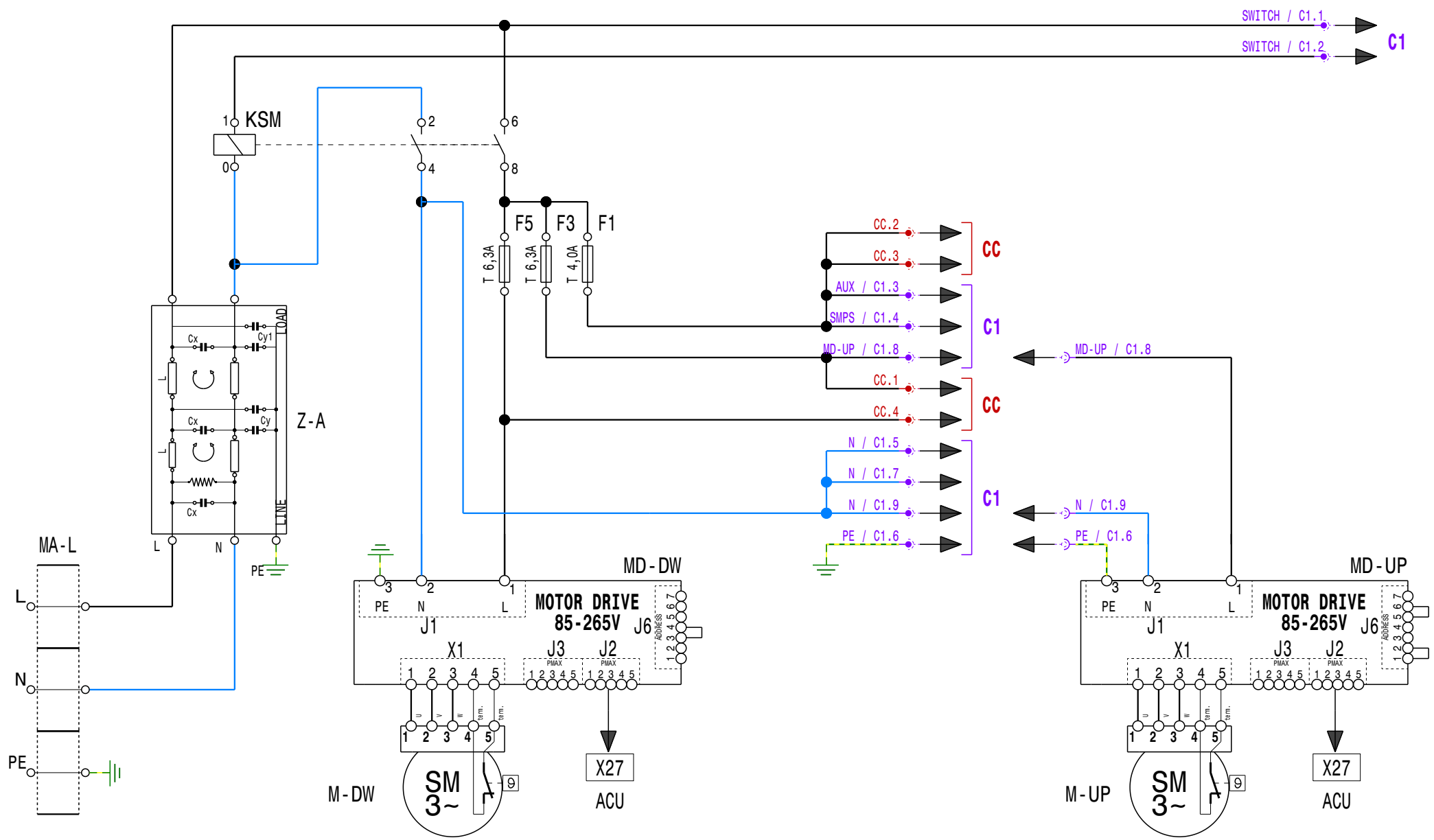

MA-L	TERMINAL BLOCK	Z-A	AUXILIARY FILTER	F1	AUXILIARY FUSE	MD-UP	MOTOR DRIVE UP	MD-DW	MOTOR DRIVE DW
		KSM	ON/OFF RELAY	F3	MD-UP FUSE	M-UP	MOTOR UP	M-DW	MOTOR DW
				F5	MD-DW FUSE				
						cod 602402R03	ELECTRIC DIAGRAM 20 "GAS" 230V 1N CKM		From S/N :

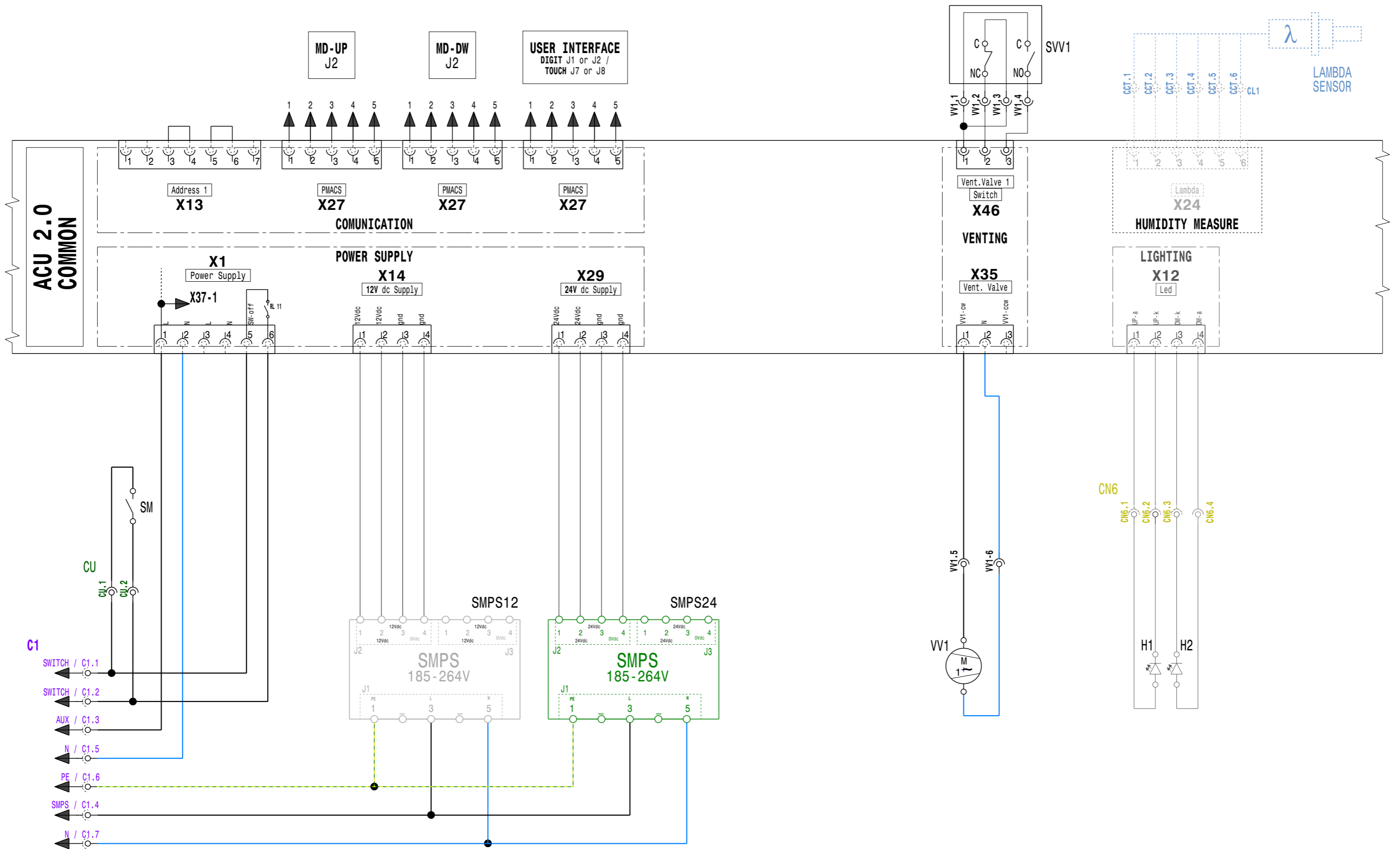

SM	MAIN SWITCH	-	-	SMPS12	SMPS 12V	VV1	VENTING VALVE 1	H1	LED LIGHTING 1	-	-
-	-	-	-	SMPS24	SMPS 24V	SVV1	VENTING VALVE SWITCHES	H2	LED LIGHTING 2	-	-
-	-	-	-	-	-	-	-	-	-	COD 602402R03 ELECTRIC DIAGRAM 20 "GAS" 230V 1N CKM	
										From S/N :	

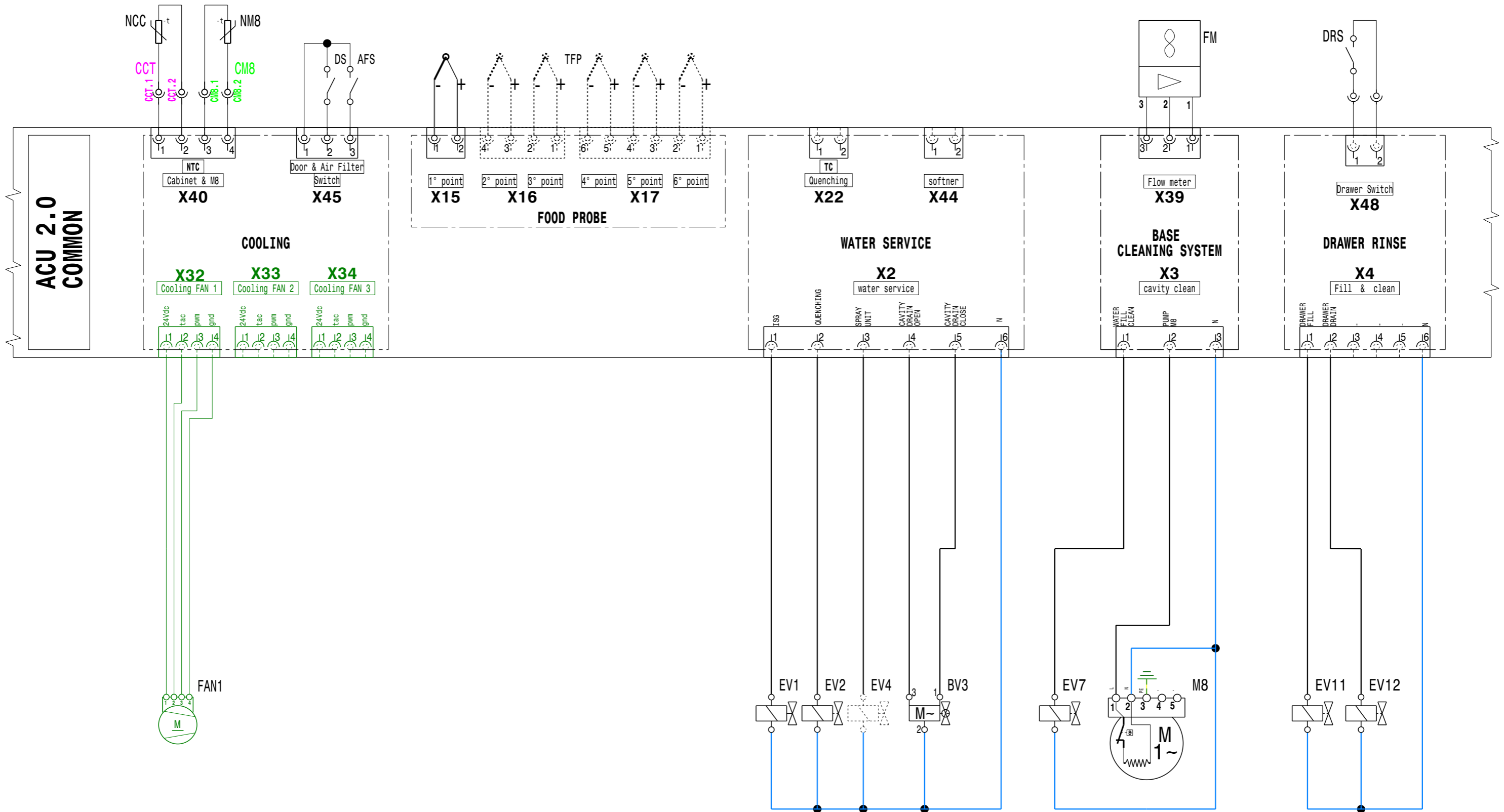

FAN1	COOLING FANS	DS	DOOR SWITCH	TFP	FOOD PROBE TEMPERATURE	FM	FLOW METER	DRS	DRAWER SWITCH
NCC	NTC CABINET COMPONENTS	AFS	AIR FILTER SWITCH	EV1	INSTANT STEAM SOLENOID VALVE	EV7	CLEANING WATER FILL S. VALVE	EV11	DRAWER FILL S. VALVE
NM8	NTC PUMP M8	-	-	EV2	QUENCHING SOL.VALVE	M8	CLEANING PUMP	EV12	DRAWER DRAIN S. VALVE
-	-	-	-	BV3	CAVITY DRAIN BALL VALVE	COD 602402R03 ELECTRIC DIAGRAM 20 "GAS" 230V 1N CKM		From S/N :	

GAS CONVECTION

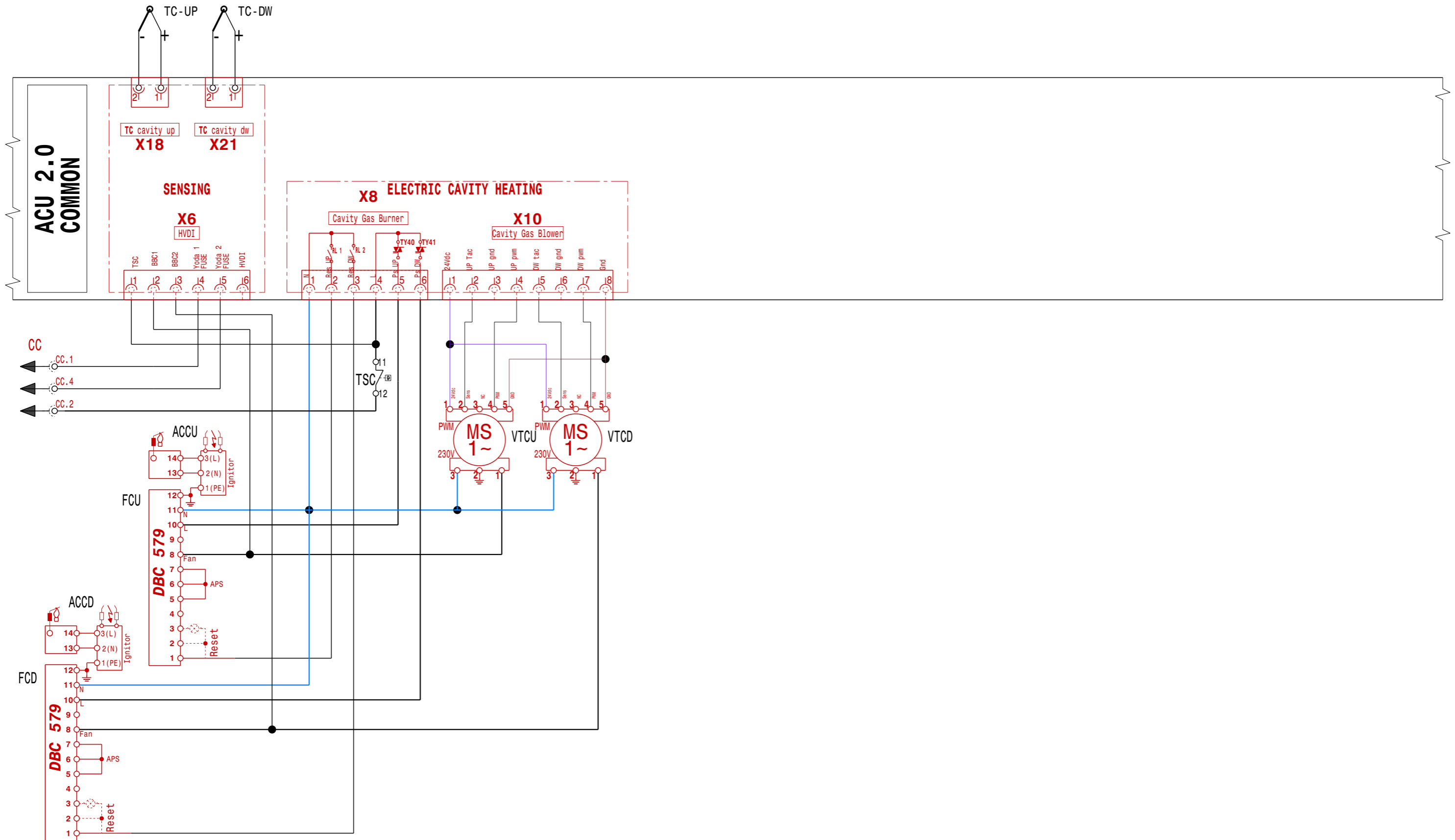

FCU	CAVITY FLAME CONTROL UP	FCD	CAVITY FLAME CONTROL DOWN	TC-UP	CAVITY UP THERMOCOUPLE	TSC	CAVITY SAFETY THERMOSTAT
ACCU	CAVITY IGNITOR UP	ACCD	CAVITY IGNITOR DOWN	TC-DW	CAVITY DOWN THERMOCOUPLE		
VTCU	CAVITY BLOWER UP	VTCD	CAVITY BLOWER DOWN	-	-	COD 602402R03	ELECTRIC DIAGRAM 20 "GAS" 230V 1N CKM

GAS CONVECTION

20 1/1 GAS BOILER (OPTION)

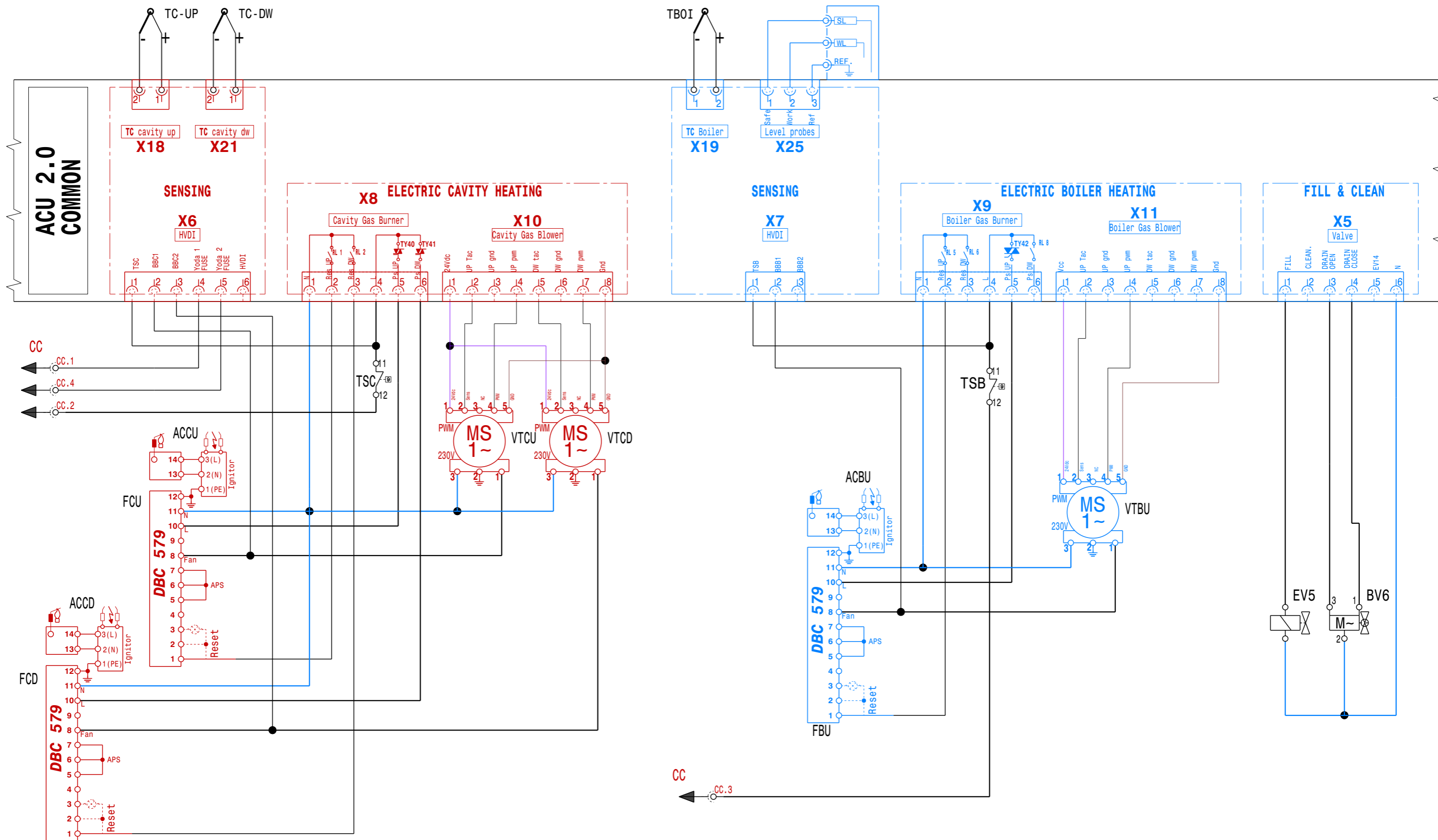

FCU CAVITY FLAME CONTROL UP	FCD CAVITY FLAME CONTROL DOWN	TC-UP CAVITY UP THERMOCOUPLE	FBU BOILER FLAME CONTROL	TBOI BOILER THERMOCOUPLE	EV5 BOILER FILL VALVE
ACCU CAVITY IGNITOR UP	ACCD CAVITY IGNITOR DOWN	TC-DW CAVITY DOWN THERMOCOUPLE	ACBU BOILER IGNITOR	TSB BOILER SAFETY THERMOSTAT	BV6 BOILER DRAIN BALL VALVE
VTCU CAVITY BLOWER UP	VTCD CAVITY BLOWER DOWN	TSC CAVITY SAFETY THERMOSTAT	VTBU BOILER BLOWER		

GAS CONVECTION

20 2/1 GAS BOILER

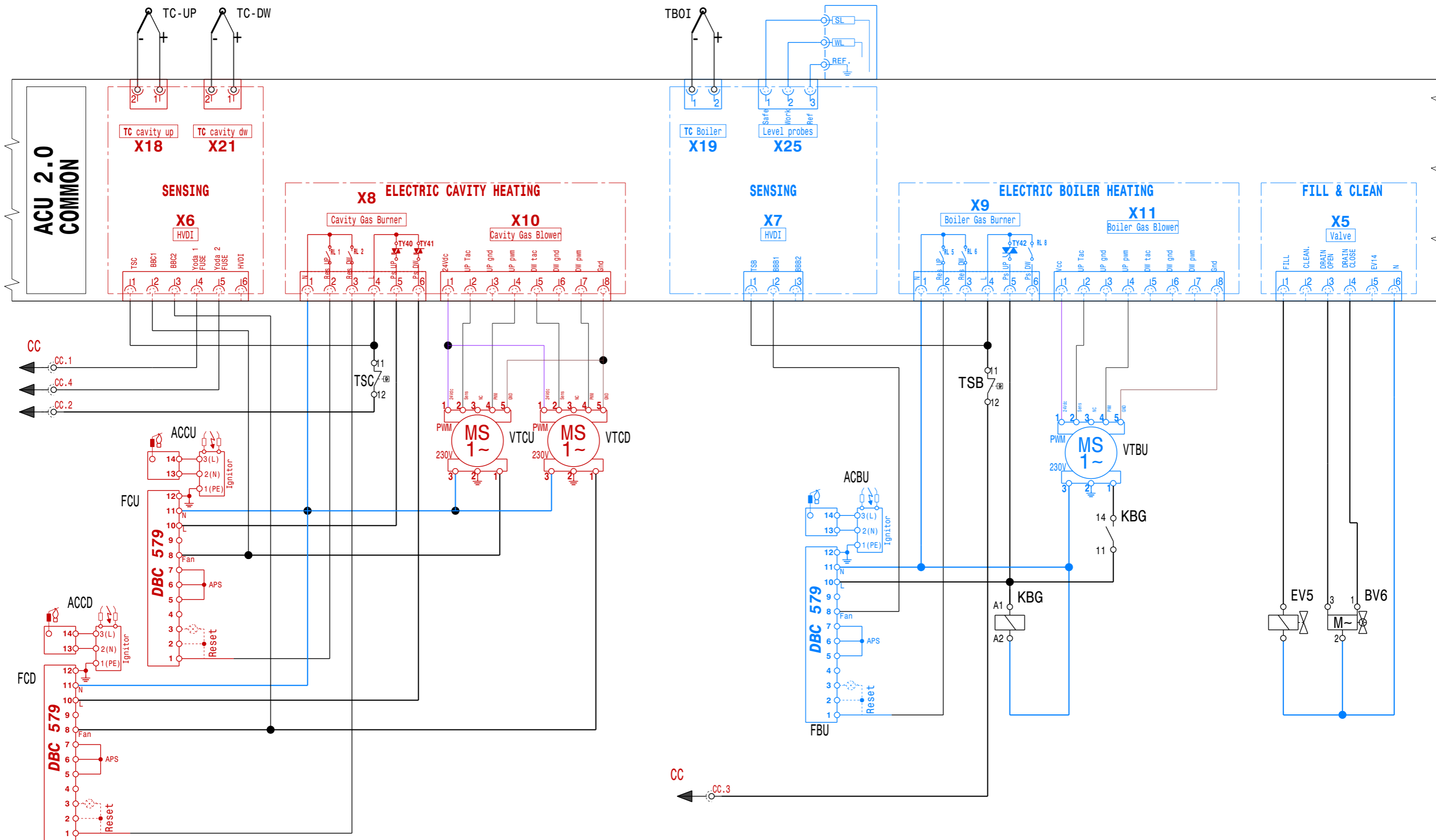

FCU CAVITY FLAME CONTROL UP	FCD CAVITY FLAME CONTROL DOWN	TC-UP CAVITY UP THERMOCOUPLE	FBU BOILER FLAME CONTROL	TBOI BOILER THERMOCOUPLE	EV5 BOILER FILL VALVE
ACCU CAVITY IGNITOR UP	ACCD CAVITY IGNITOR DOWN	TC-DW CAVITY DOWN THERMOCOUPLE	ACBU BOILER IGNITOR	TSB BOILER SAFETY THERMOSTAT	BV6 BOILER DRAIN BALL VALVE
VTCU CAVITY BLOWER UP	VTCD CAVITY BLOWER DOWN	TSC CAVITY SAFETY THERMOSTAT	VTBU BOILER BLOWER	KBG BOILER BLOWER RELAY	

ACCESSORIES

"GAS"

FAT DRAIN SYSTEM

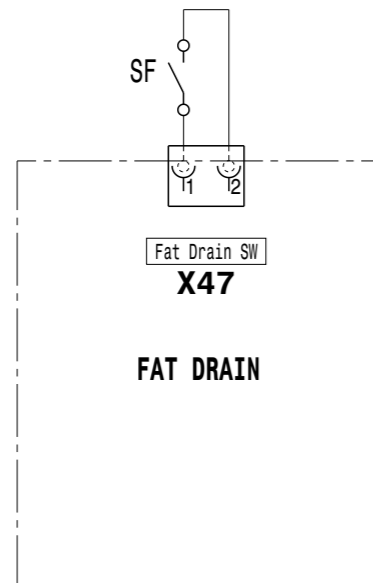

LIQUID CLEANING

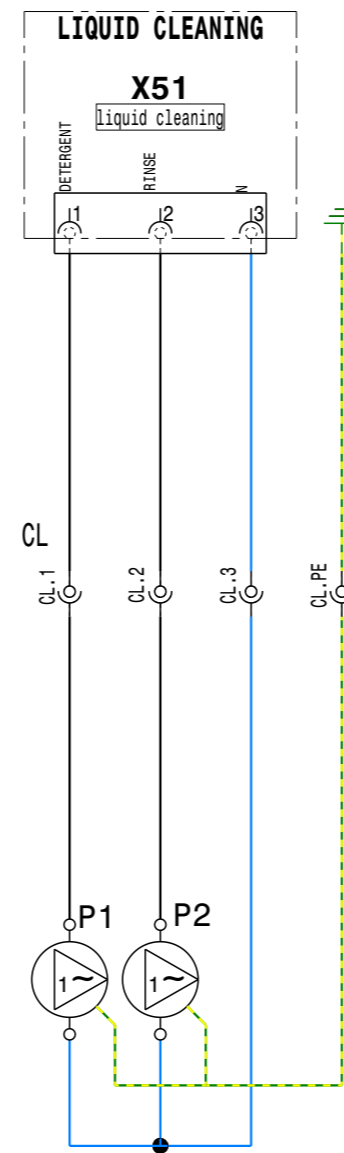

EXTRACTION HOOD

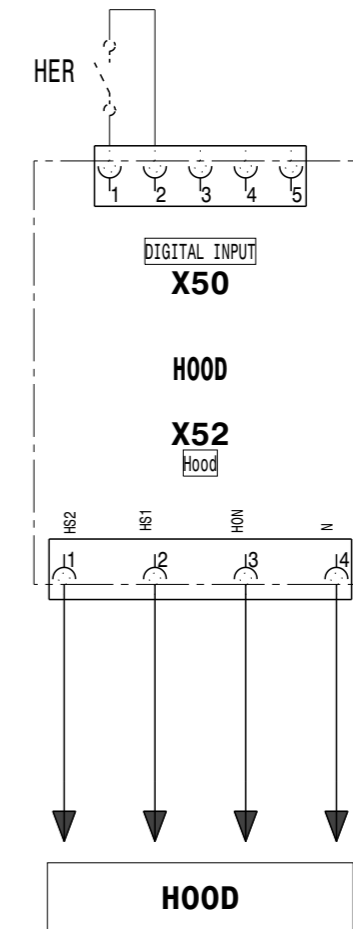

SF	FAT DRAIN SWITCH	-	-	P1	RINSE PUMP	-	-	-	-
-	-	-	-	P2	DETERGENT PUMP	-	-	-	-
-	-	-	-	-	-	-	-	cod 602402R03	ELECTRIC DIAGRAM 20 "GAS" 230V 1N CKM
									From S/N :