



**MOD : SGBT/10S**

**Production code : 228707**

**01/2026**

# GAS OVENS

## Electrical Documentation

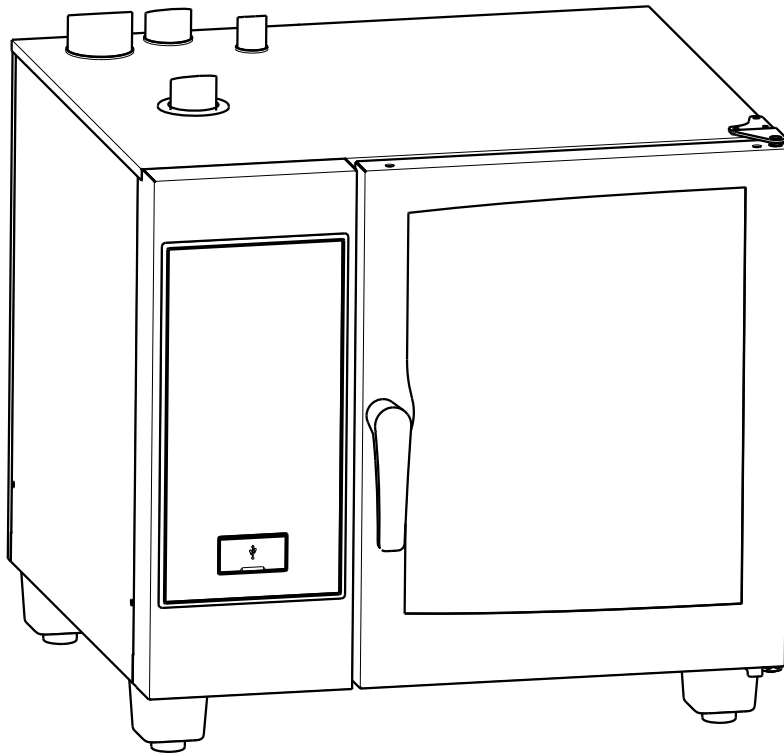

6 1/1  
&  
6 2/1

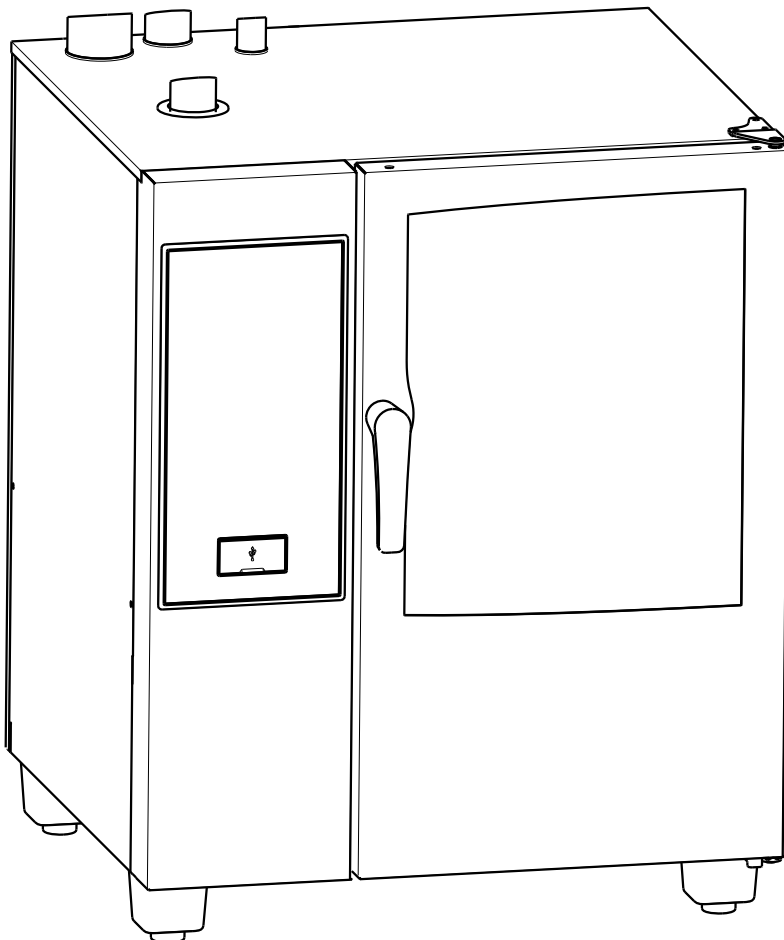

10 1/1  
&  
10 2/1

# MAIN BOARD ACU

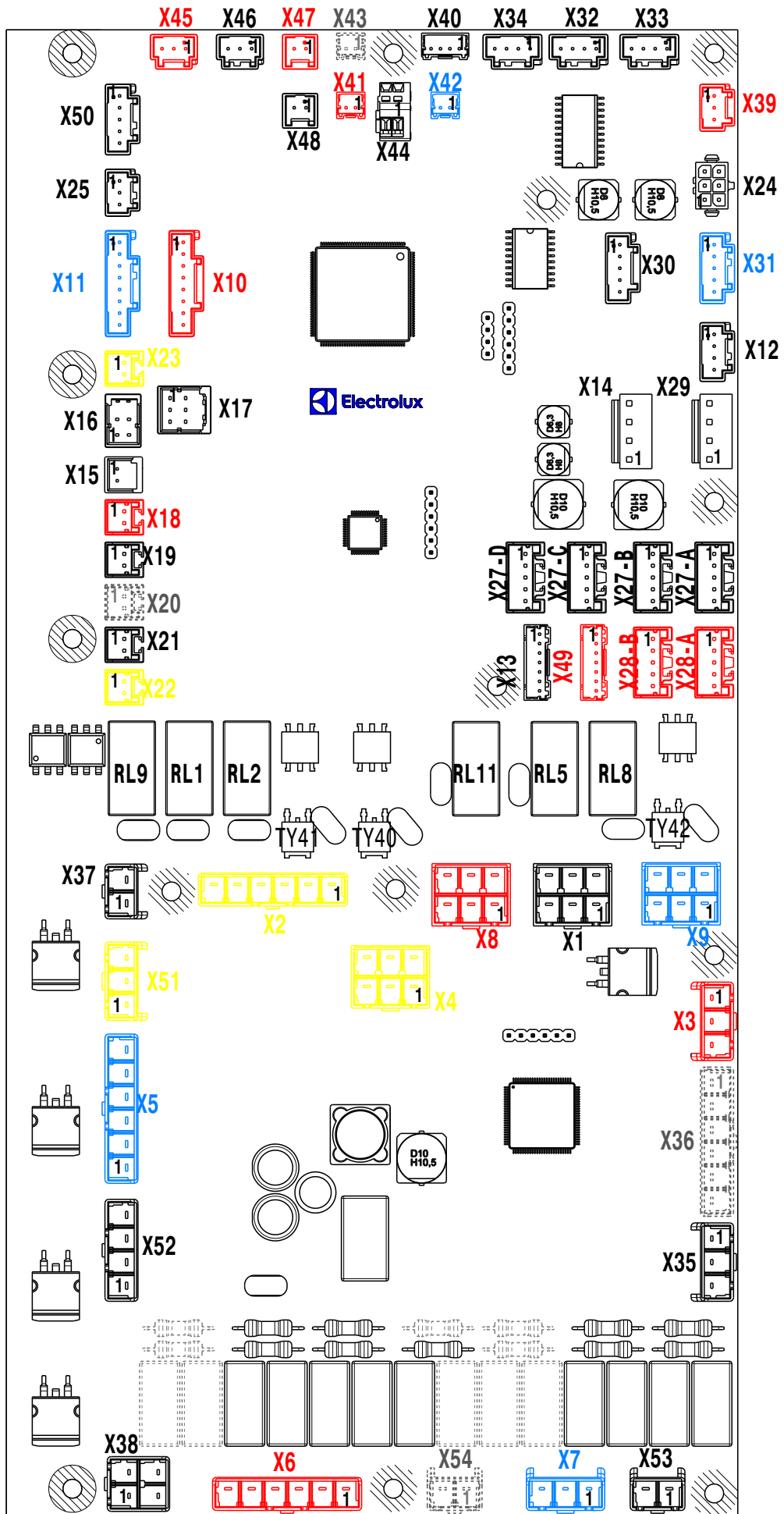

# ACU LEGENDA

Ref.	Group	Pin	Direct.	Function
X1	Power Supply	1	IN	L Power Supply
		2	IN	N Power Supply
		3	IN	L Power Supply
		4	IN	N Power Supply
		5	IN	
		6	OUT	SW-OFF Auto switch off
X2	Water Service	1	OUT	EV1 Instant steam solenoid valve
		2	OUT	EV2 Quenching solenoid valve
		3	OUT	EV4 Spray unit solenoid valve
		4	OUT	BV3 Cavity drain ball valve OPEN
		5	OUT	BV3 Cavity drain ball valve CLOSE
		6	OUT	N
X3	Clean. Syst. Basic	1	OUT	EV7 Cleaning water fill solenoid valve
		2	OUT	M8 Cleaning pump
		3	OUT	N
X4	Cleaning System Drawer Rinse	1	OUT	EV11 Drawer fill solenoid valve
		2	OUT	EV12 Drawer drain solenoid valve
		3	OUT	
		4	OUT	
		5	OUT	
		6	OUT	N
X5	Boiler Fill & Clean	1	OUT	EV5 Boiler fill solenoid valve
		2	OUT	
		3	OUT	BV6 Boiler drain ball valve OPEN
		4	OUT	BV6 Boiler drain ball valve CLOSE
		5	OUT	
		6	OUT	N
X6	Sensing	1	IN	TSC Cavity safety thermostat
		2	IN	BBC1 Cavity gas blower burner
		3	IN	
		4	IN	HV14 Motor drive fuse
		5	IN	
		6	IN	
X7	Sensing	1	IN	TSB Boiler safety thermostat
		2	IN	BBB1 Boiler gas blower burner
		3	IN	
X8	Cavity GAS burner	1	OUT	N
		2	OUT	FCU Cavity flame control unit reset
		3	OUT	
		4	IN	FCU Cavity flame control unit power supply IN
		5	OUT	FCU Cavity flame control unit power supply OUT
		6	OUT	
X9	Boiler GAS burner	1	OUT	N
		2	OUT	FBU Boiler flame control unit reset
		3	OUT	
		4	IN	FBU Boiler flame control unit power supply IN
		5	OUT	FBU Boiler flame control unit power supply OUT
		6	OUT	
X10	Cavity GAS blower	1	OUT	VTCU Cavity blower control Power supply
		2	IN	VTCU Cavity blower control Tachometer
		3	IN	
		4	OUT	VTCU Cavity blower control Speed
		5	IN	
		6	IN	
		7	OUT	
		8	OUT	VTCU Boiler blower control GND
X11	Boiler GAS blower	1	OUT	VTBU Boiler blower control Power supply
		2	IN	VTBU Boiler blower control Tachometer
		3	IN	
		4	OUT	VTBU Boiler blower control Speed control
		5	IN	
		6	IN	
		7	OUT	
		8	OUT	VTBU Boiler blower control GND

Ref.	Group	Pin	Direct.	Function
X12	Led	1	OUT	H1 LED lighting 1 anode
		2	IN	H1 LED lighting 1 catode
		3	IN	H2 LED lighting 2 catode
		4	OUT	H2 LED lighting 2 anode
X13				Adress
X14	12V	1	IN	+12V dc
		2	IN	
		3	IN	0V dc
		4	IN	
X15	Food probe temperature	A1	IN	TFP 1 <sup>st</sup> point food probe temperature
		B1	IN	
X16	Food probe temperature	A1	IN	TFP 2 <sup>nd</sup> point food probe temperature
		B1	IN	
		A2	IN	TFP 3 <sup>rd</sup> point food probe temperature
		B2	IN	
X17	Food probe temperature	A1	IN	TFP 4 <sup>th</sup> point food probe temperature
		B1	IN	
		A2	IN	TFP 5 <sup>th</sup> point food probe temperature
		B2	IN	
		A3	IN	TFP 6 <sup>th</sup> point food probe temperature
		B3	IN	
X18	Temper.	1	IN	TCAV Cavity Thermocouple
X19	Temper.	1	IN	
		2	IN	TBO1 Boiler Thermocouple
X20	Temper.			-- NOT USE --
X21	Temper.			-- NOT USE --
X22	Temper.	1	IN	
		2	IN	TQS Quenching System Thermocouple
X23	Temper.	1	IN	
		2	IN	TAR Aromatizer Thermocouple
X24	Lambda			Lambda sensor
X25	Boiler level	1	IN/OUT	SL Boiler safety level dection probe
		2	IN/OUT	WL Boiler working level dection probe
		3	IN	REF Boiler level detection probes reference
X27-A			IN/OUT	PMACS communication BUS
X27-B			IN/OUT	PMACS communication BUS
X27-C			IN/OUT	PMACS communication BUS
X27-D			IN/OUT	PMACS communication BUS
X28-A			IN/OUT	PMACS Recovery communication BUS
X28-B			IN/OUT	PMACS Recovery communication BUS
X29	24V	1	IN	+24V dc
		2	IN	
		3	IN	
		4	IN	0V dc
X30	Cavity SSR	1	OUT	KC1 Cavity 1 solid state relay
		2	OUT	KC2 Cavity 2 solid state relay
		3	OUT	
		4	OUT	
		5	OUT	0V dc
X31	Boiler SSR	1	OUT	KB1 Boiler 1 solid state relay
		2	OUT	KB2 Boiler 2 solid state relay
		3	OUT	
		4	OUT	
		5	OUT	0V dc

Ref.	Group	Pin	Direct.	Function
X32	Cooling Fan 1	1	OUT	FAN1 Cooling fan 1 power supply 24Vdc
		2	IN	FAN1 Cooling fan 1 tachometer sensor
		3	OUT	FAN1 Cooling fan 1 speed control
		4	OUT	FAN1 Cooling fan 1 power supply 0Vdc
X33	Cooling Fan 2			-- NOT USE --
X34	Cooling Fan 3			-- NOT USE --
X35	Vent. Valve	1	OUT	VV1 Venting valve 1 cw rotation
		2	OUT	N
		3	OUT	VV1 Venting valve 1 ccw rotation
X36				-- NOT USE --
X37	KS	1	OUT	KS Safety contactor
		2	OUT	
X38	Smoker	1	OUT	N
		2	OUT	R1 (Smoker heating element)
		3	OUT	
		4	IN	
X39	Flow meter	1	OUT	+24V dc
		2	OUT	FM Flow meter reference
		3	IN	FM Flow meter feedback
X40	Temper.	1	OUT	NCC NTC cabinet components
		2	IN	
		3	OUT	NM8 NTC pump M8
		4	IN	
X41	Temper.	1	OUT	NHSC NTC Cavity SSR heatsink
		2	IN	
X42	Temper.	1	OUT	NHSB NTC Boiler SSR heatsink
		2	IN	
X43	Temper.			-- NOT USE --
X44	Softner	1	OUT	SSW1 Softner interface
		2	IN	
X45	Switch	1	OUT	24V Reference
		2	IN	DS Door switch
		3	IN	AFS Air filter switch
X46	switch	1	OUT	24V Reference
		2	IN	SVV1 Venting valve CLOSE switch
X47		1	IN	SVV1 Venting valve OPEN switch
		2	OUT	24V Reference
X48	Switch	1	OUT	SF Fat drain valve status switch
		2	IN	24V Reference
X49		1	IN	DRS Cleaning drawer switch
		2	IN	Recovery Address
X50		1	OUT	24V Reference
		2	IN	HER Hood error
		3	IN	
		4	IN	
		5	IN	
X51	Liquid Clean. Syst.	1	OUT	P1 Liquid dergent pump
		2	OUT	P2 Liquid rinse pump
		3	OUT	N
X52		1	OUT	HS2 Hood speed 2
		2	OUT	HS1 Hood speed 1
		3	OUT	HON Hood ON
		4	OUT	N Neutral
X53		1	IN	PPM1 Peak power managment 1 / Usa Hood
		2	IN	PPM2 Peak power managment 2
X54				-- NOT USE --

# LOGIC DIAGRAM

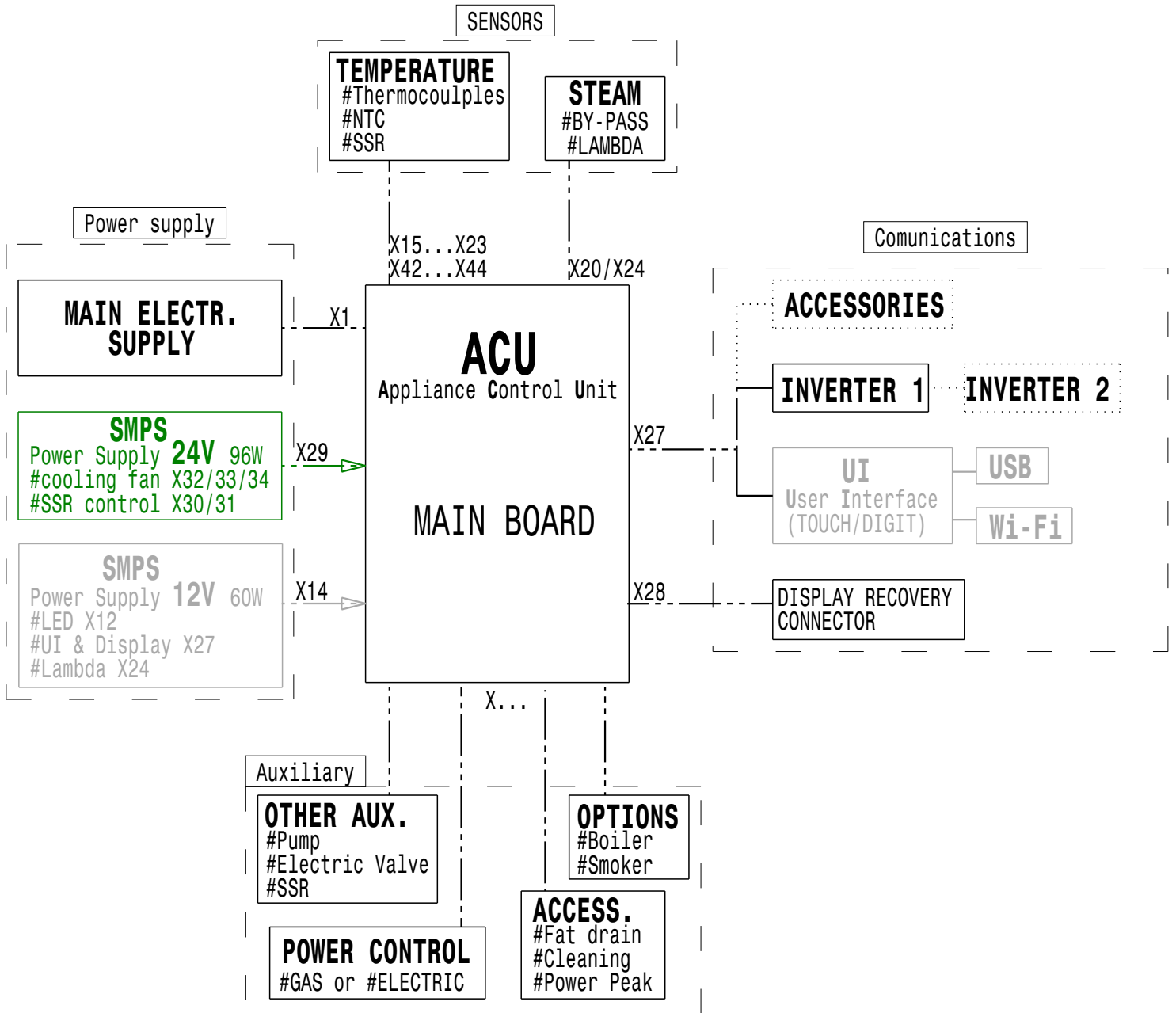

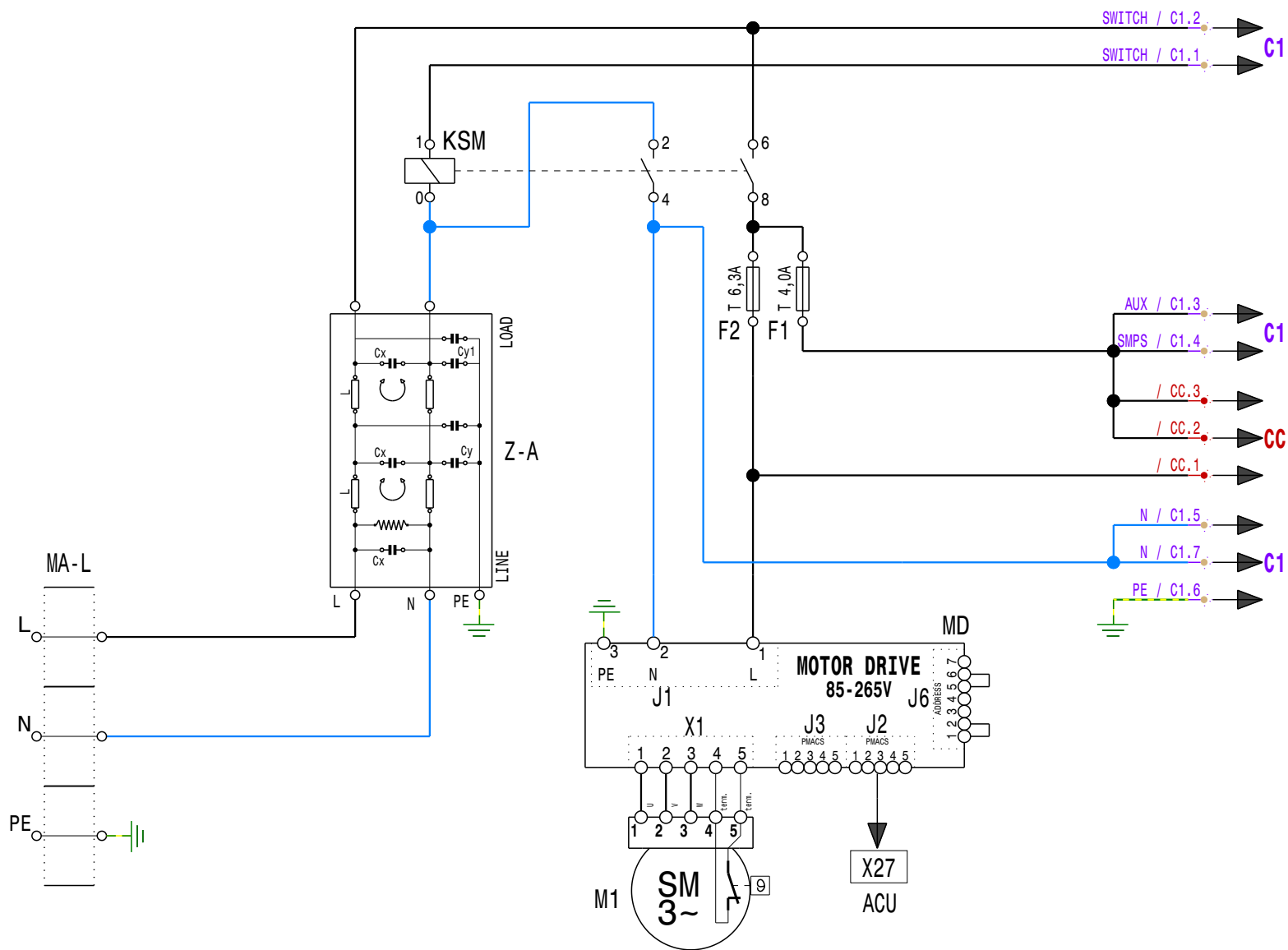

MA-L	TERMINAL BLOCK	Z-A	AUXILIARY FILTER	MD	MOTOR DRIVE	F1	AUXILIARY FUSE	-	-	-	-
-	-	KSM	ON/OFF RELAY	M1	MOTOR	F2	MOTOR DRIVE FUSE	-	-	-	-
-	-	-	-	-	-	-	-	COD 602402P03 ELECTRIC DIAGRAM 6/10 "GAS" 220-240V 1N CKM			From S/N :

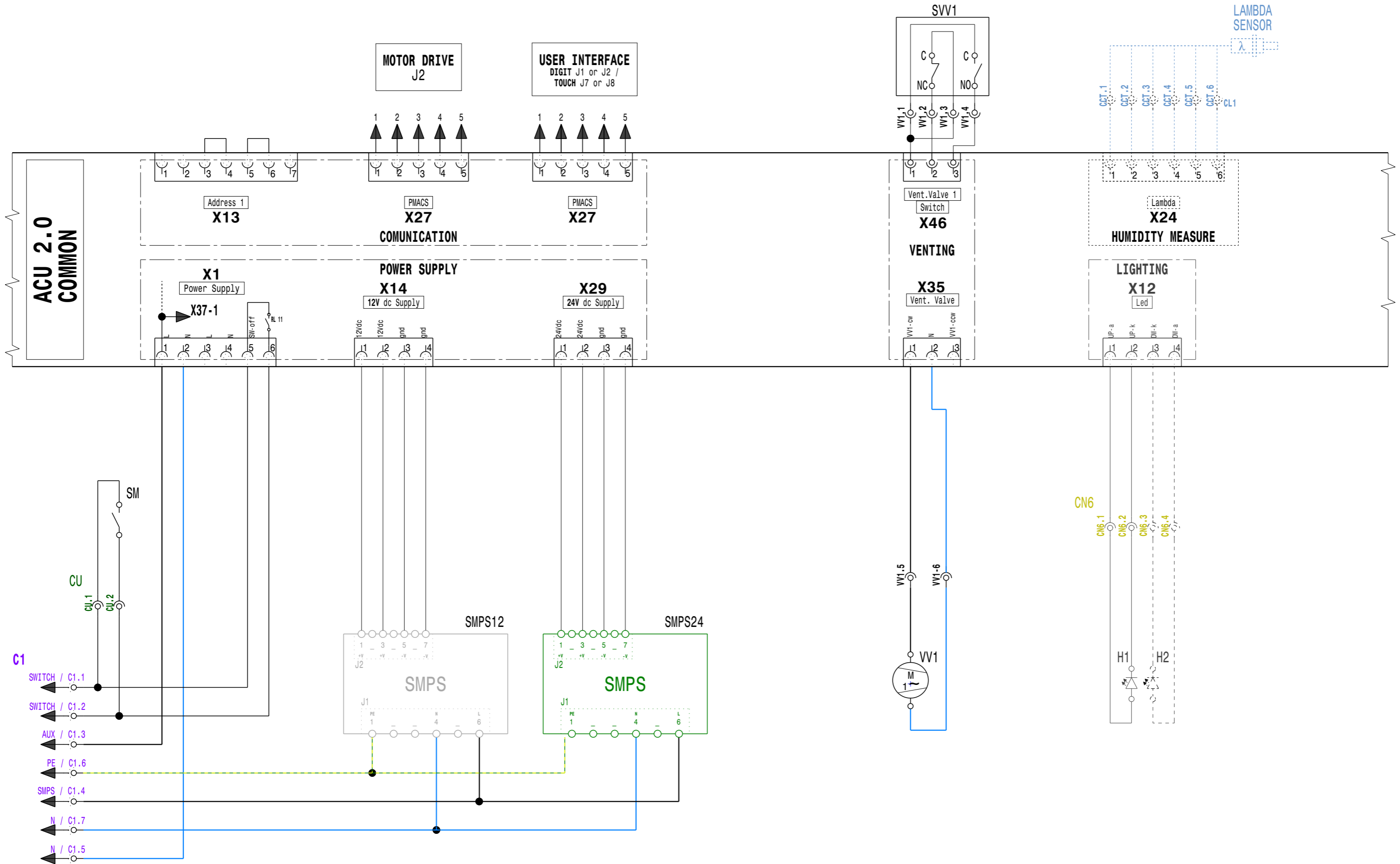

SM	MAIN SWITCH	-	-	SMPS12	SMPS 12V	VV1	VENTING VALVE 1	H1	LED LIGHTING 1	-	-
-	-	-	-	SMPS24	SMPS 24V	SVV1	VENTING VALVE SWITCHES	H2	LED LIGHTING 2	-	-
-	-	-	-	-	-	-	-	-	-	COD 602402P03   ELECTRIC DIAGRAM 6/10 "GAS" 220-240V 1N CKM	
										From S/N :	

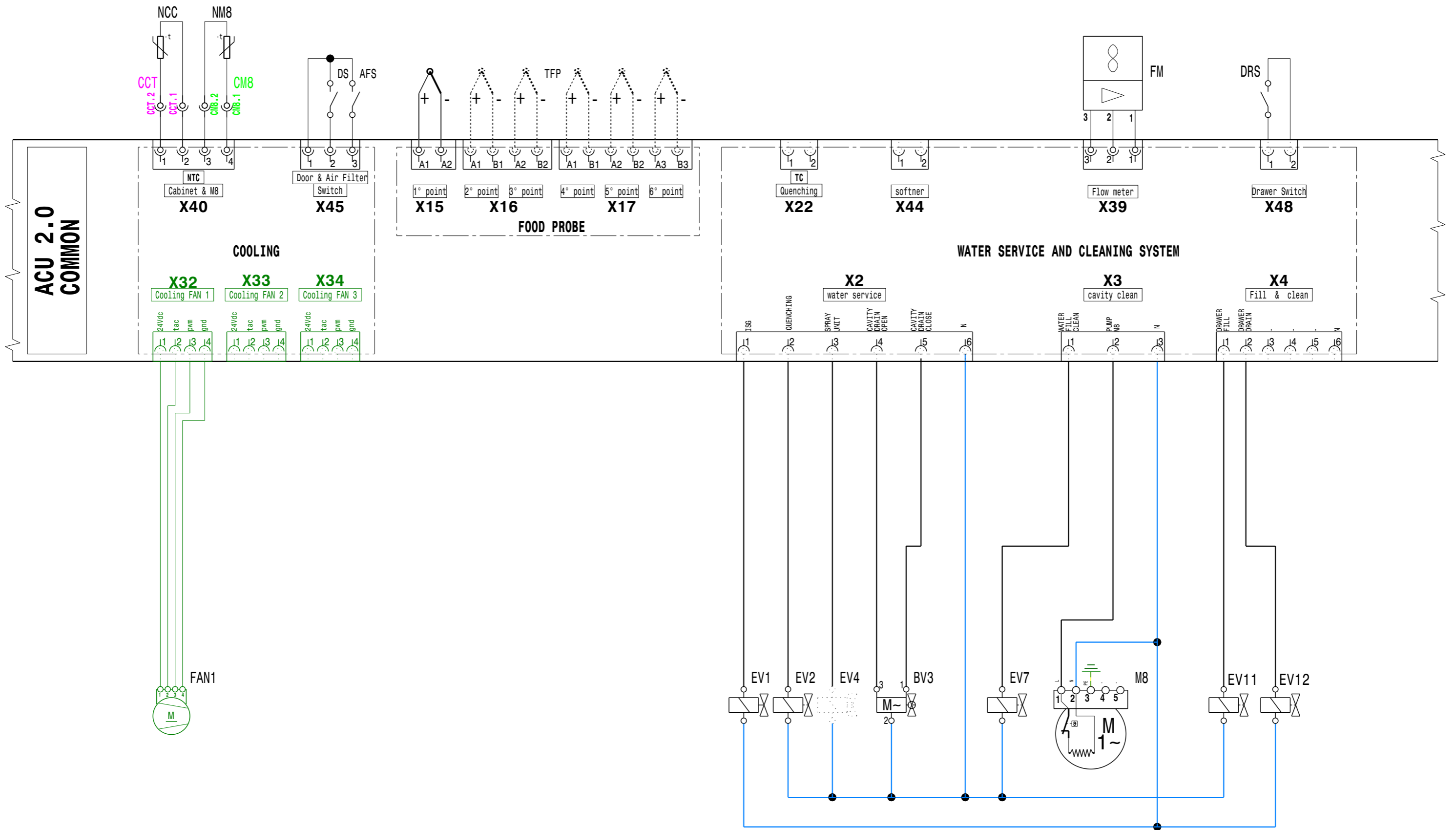

<b>FAN1</b>	COOLING FAN	<b>DS</b>	DOOR SWITCH	<b>TFP</b>	FOOD PROBE TEMPERATURE	<b>FM</b>	FLOW METER	<b>DRS</b>	DRAWER SWITCH
<b>NCC</b>	NTC CABINET COMPONENTS	<b>AFS</b>	AIR FILTER SWITCH	<b>EV1</b>	INSTANT STEAM SOLENOID VALVE	<b>EV7</b>	CLEANING WATER FILL S. VALVE	<b>EV11</b>	DRAWER FILL S. VALVE
<b>NM8</b>	NTC PUMP M8	-	-	<b>EV2</b>	QUENCHING SOL.VALVE	<b>M8</b>	CLEANING PUMP	<b>EV12</b>	DRAWER DRAIN S. VALVE
-	-	-	-	<b>BV3</b>	CAVITY DRAIN BALL VALVE	COD 602402P03   ELECTRIC DIAGRAM 6/10 "GAS" 220-240V 1N CKM		From S/N :	

## GAS CONVECTIONS

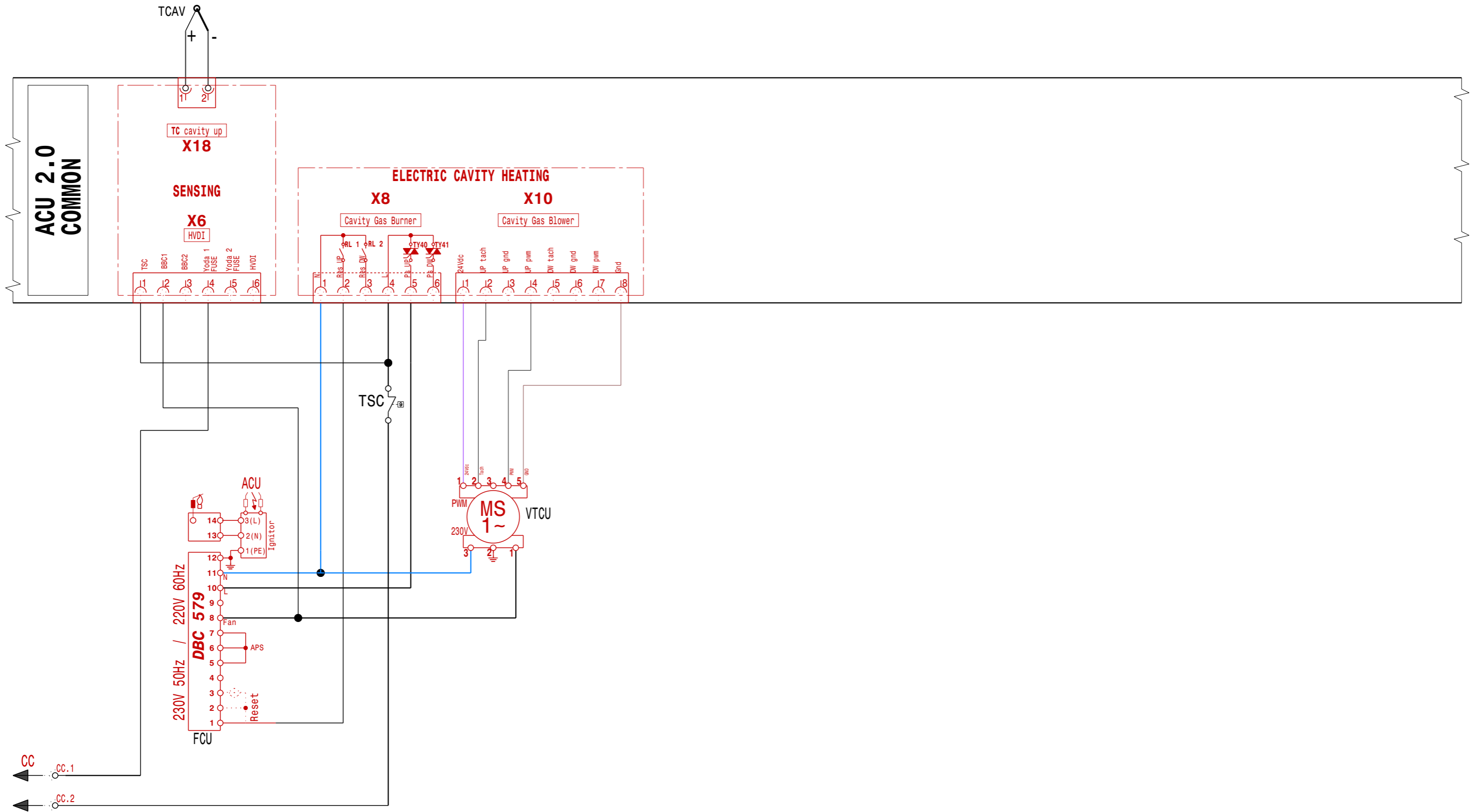

-	-	<b>FCU</b>	CAVITY FLAME CONTROL UNIT
-	-	<b>ACCU</b>	CAVITY IGNITOR
-	-	<b>TSC</b>	CAVITY SAFETY THERMOSTAT

<b>VTCU</b>	CAVITY BLOWER
<b>TCAV</b>	CAVITY THERMOCOUPLE
-	-

# BOILER

# "GAS"

## GAS CONVECTIONS

## GAS BOILER (OPTION)

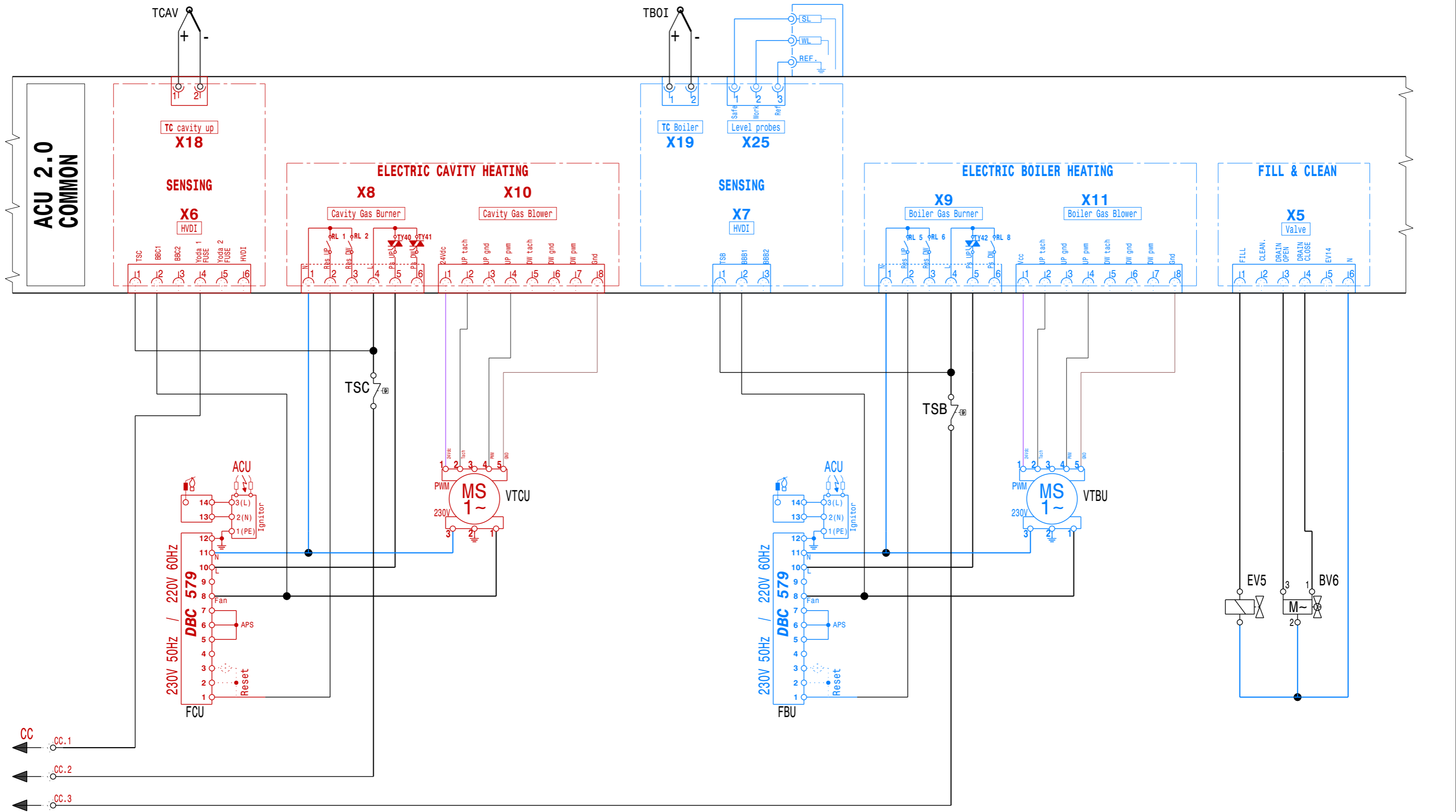

<b>TSC</b>	CAVITY SAFETY THERMOSTAT	<b>FCU</b>	CAVITY FLAME CONTROL UNIT	<b>TSB</b>	BOILER SAFETY THERMOSTAT	<b>FBU</b>	BOILER FLAME CONTROL UNIT	<b>EV5</b>	BOILER FILL SOLENOID VALVE
<b>TCAV</b>	CAVITY THERMOCOUPLE	<b>ACCU</b>	CAVITY IGNITOR	<b>TBOI</b>	BOILER THERMOCOUPLE	<b>ACCU</b>	BOILER IGNITOR	<b>BV6</b>	BOILER DRAIN BALL VALVE
		<b>VTCU</b>	CAVITY BLOWER			<b>VTBU</b>	BOILER BLOWER		

## FAT DRAIN SYSTEM

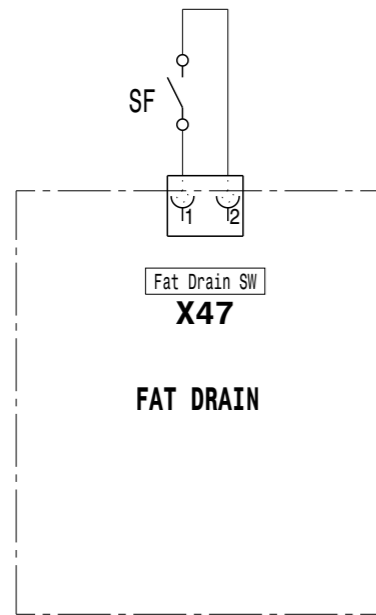

## LIQUID CLEANING

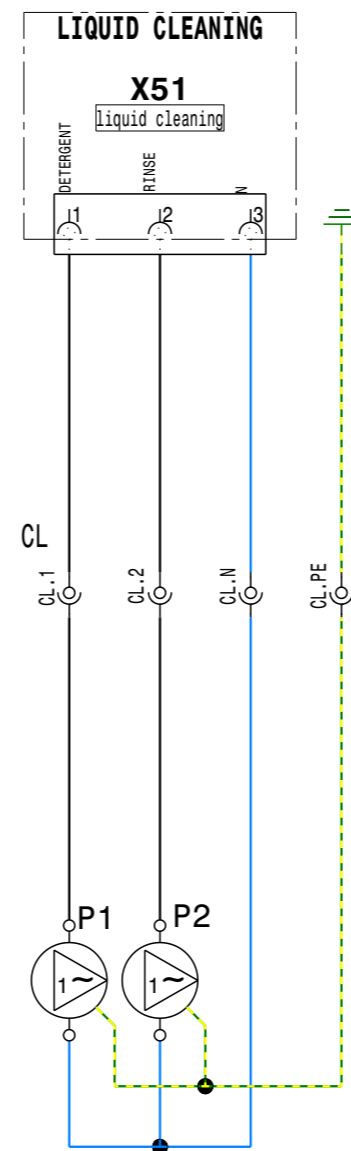

## EXTRACTION HOOD

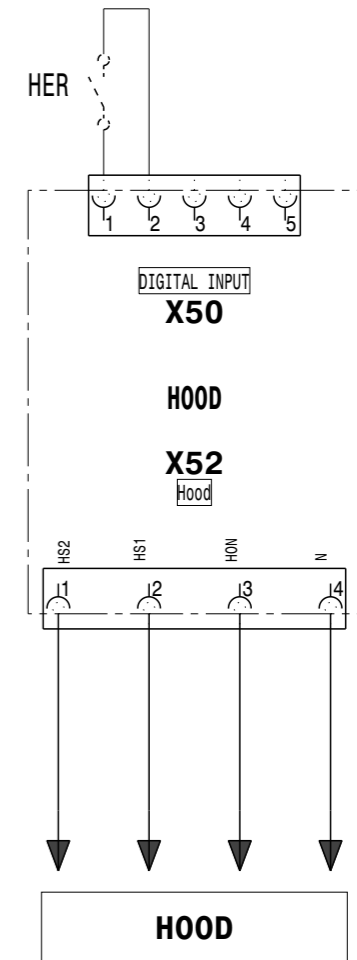

BV15	FAT DRAIN BALL VALVE	-	-
SF	FAT DRAIN SWITCH	-	-
-	-	-	-

P1	RINSE PUMP	-	-
P2	DETERGENT PUMP	-	-
-	-	-	-