



**MOD : SBET/20S**

**Production code : 228705**

**01/2026**

# **ELECTRIC** OVENS

## Electrical Documentation

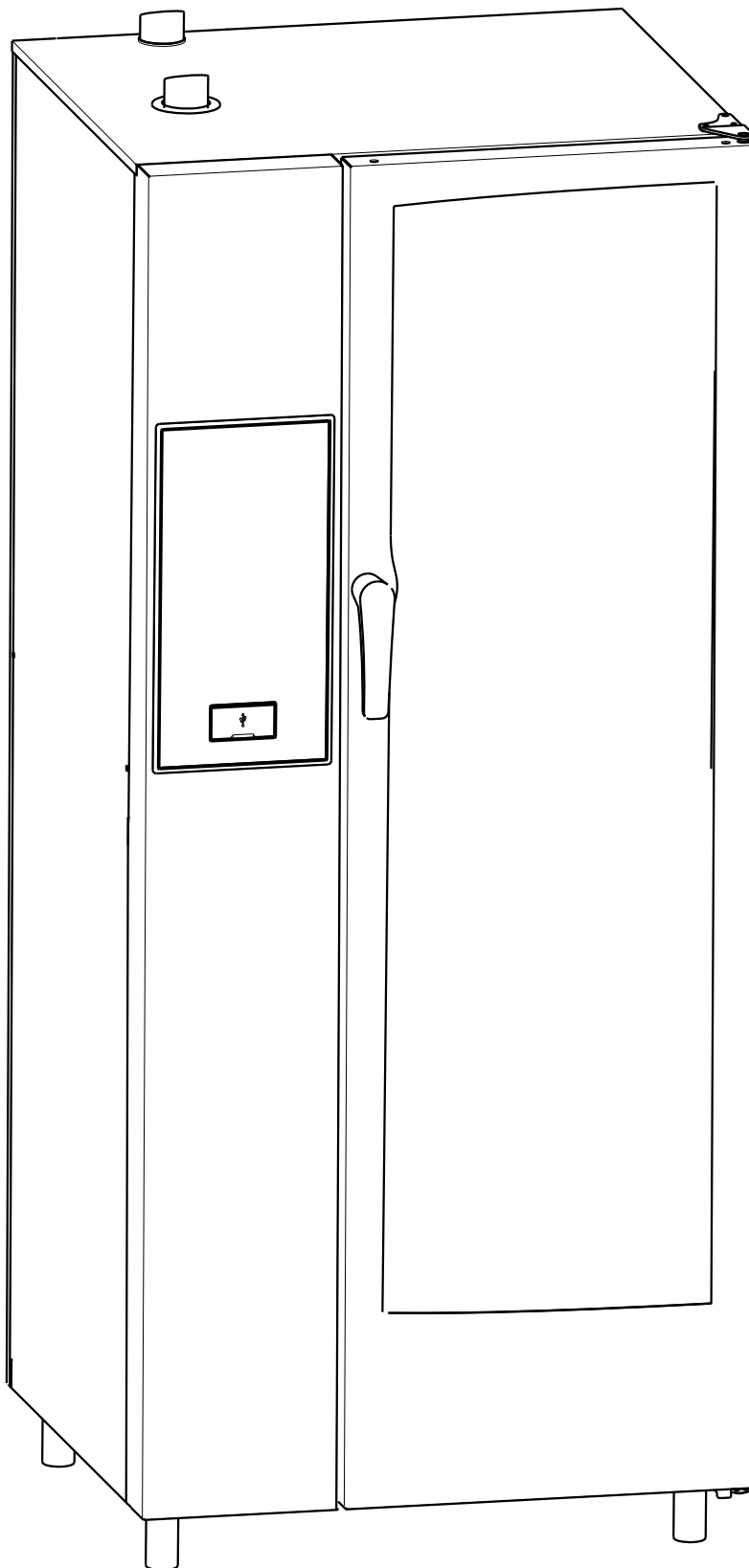

20 1/1  
&  
20 2/1

# MAIN BOARD ACU

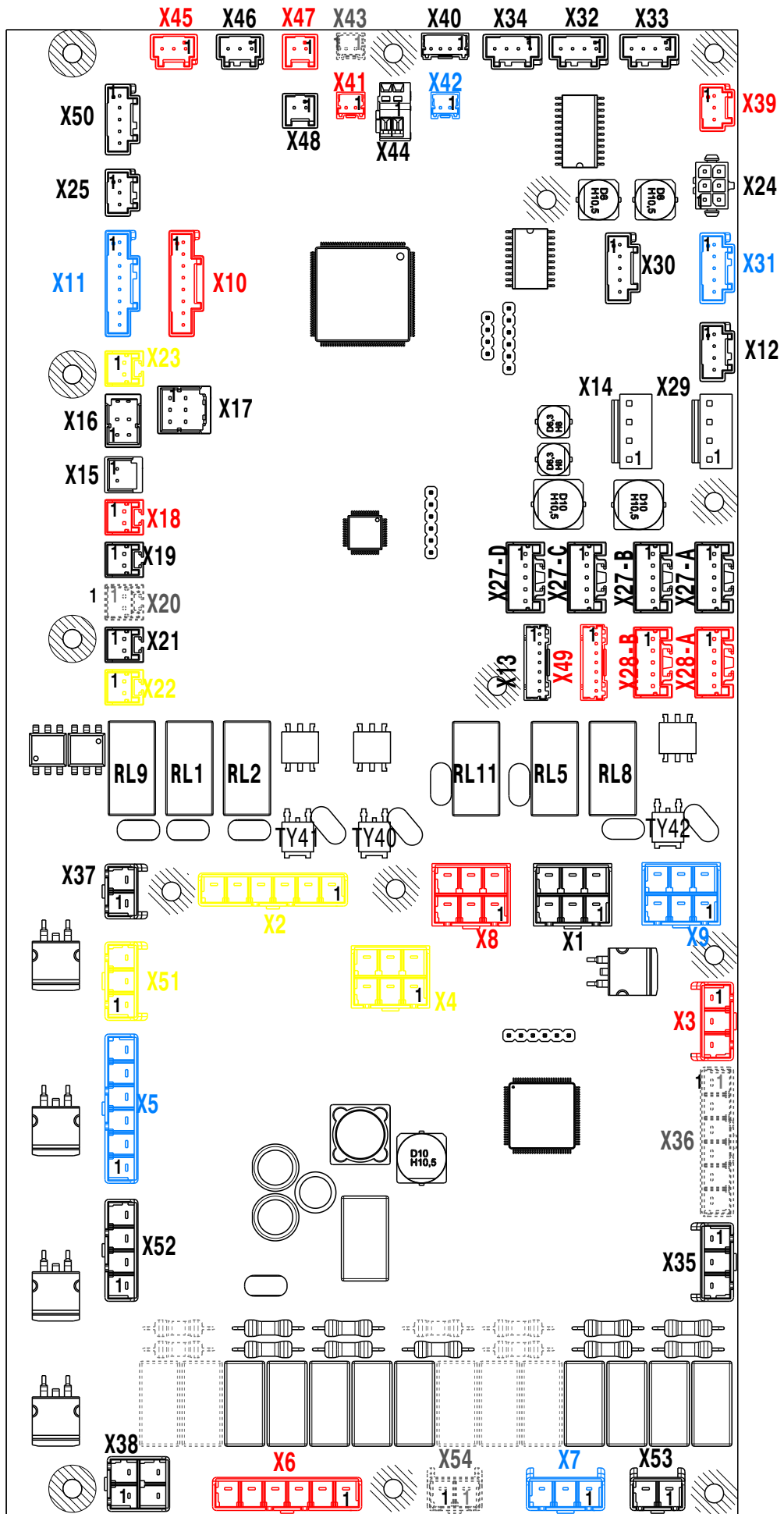

# ACU LEGENDA

Ref.	Group	Pin	Direct.	Function
X1	Power Supply	1	IN	L Power Supply
		2	IN	N Power Supply
		3	IN	L Power Supply
		4	IN	N Power Supply
		5	IN	SW-OFF Auto switch off
		6	OUT	
X2	Water Service	1	OUT	EV1 Instant steam solenoid valve
		2	OUT	EV2 Quenching solenoid valve
		3	OUT	EV4 Spray unit solenoid valve
		4	OUT	BV3 Cavity drain ball valve OPEN
		5	OUT	BV3 Cavity drain ball valve CLOSE
		6	OUT	N
X3	Clean. Syst. Basic	1	OUT	EV7 Cleaning water fill solenoid valve
		2	OUT	M8 Cleaning pump
		3	OUT	N
X4	Cleaning System Drawer Rinse	1	OUT	EV11 Drawer fill solenoid valve
		2	OUT	EV12 Drawer drain solenoid valve
		3	OUT	
		4	OUT	
		5	OUT	
		6	OUT	N
X5	Boiler Fill & Clean	1	OUT	EV5 Boiler fill solenoid valve
		2	OUT	
		3	OUT	BV6 Boiler drain ball valve OPEN
		4	OUT	BV6 Boiler drain ball valve CLOSE
		5	OUT	
		6	OUT	N
X6	Sensing	1	IN	TSC Cavity safety thermostat
		2	IN	BBC1 Cavity gas blower burner UP
		3	IN	BBC2 Cavity gas blower burner DOWN
		4	IN	HV14 Motor drive fuse UP
		5	IN	HV15 Motor drive fuse DOWN
		6	IN	
X7	Sensing	1	IN	TSB Boiler safety thermostat
		2	IN	BBB1 Boiler gas blower burner
		3	IN	
X8	Cavity GAS burner	1	OUT	N
		2	OUT	FCU Cavity flame control unit reset UP
		3	OUT	FCU Cavity flame control unit reset DOWN
		4	IN	FCU Cavity flame control units power supply IN
		5	OUT	FCU Cavity flame control unit power supply UP
		6	OUT	FCU Cavity flame control unit power supply DOWN
X9	Boiler GAS burner	1	OUT	N
		2	OUT	FBU Boiler flame control unit reset
		3	OUT	
		4	IN	FBU Boiler flame control unit power supply IN
		5	OUT	FBU Boiler flame control unit power supply OUT
		6	OUT	
X10	Cavity GAS blower	1	OUT	VTCU Cavity blower control Power supply
		2	IN	VTCU Cavity blower control Tachometer UP
		3	IN	
		4	OUT	VTCU Cavity blower control Speed UP
		5	IN	VTCU Cavity blower control Tachometer DOWN
		6	IN	
		7	OUT	VTCU Cavity blower control Speed DOWN
		8	OUT	VTCU Boiler blower control GND
X11	Boiler GAS blower	1	OUT	VTBU Boiler blower control Power supply
		2	IN	VTBU Boiler blower control Tachometer
		3	IN	
		4	OUT	VTBU Boiler blower control Speed control
		5	IN	
		6	IN	
		7	OUT	
		8	OUT	VTBU Boiler blower control GND

Ref.	Group	Pin	Direct.	Function
X12	Led	1	OUT	H1 LED lighting 1 anode
		2	IN	H1 LED lighting 1 catode
		3	IN	H2 LED lighting 2 catode
		4	OUT	H2 LED lighting 2 anode
X13			Adress	
X14	12V	1	IN	+12V dc
		2	IN	
		3	IN	0V dc
		4	IN	
X15	Food probe temperature	A1	IN	TFP 1 <sup>st</sup> point food probe temperature
		A2	IN	
X16	Food probe temperature	B1	IN	TFP 2 <sup>nd</sup> point food probe temperature
		A2	IN	TFP 3 <sup>rd</sup> point food probe temperature
X17	Food probe temperature	B2	IN	TFP 4 <sup>th</sup> point food probe temperature
		A1	IN	TFP 5 <sup>th</sup> point food probe temperature
		A2	IN	
		B2	IN	
		A3	IN	TFP 6 <sup>th</sup> point food probe temperature
		B3	IN	
X18	Temper.	1	IN	TCAV Cavity Thermocouple UP
		2	IN	
X19	Temper.	1	IN	TBOI Boiler Thermocouple
		2	IN	
X20	Temper.		-- NOT USE --	
X21	Temper.	1	IN	TCAV Cavity Thermocouple DOWN
		2	IN	
X22	Temper.	1	IN	TQS Quenching System Thermocouple
		2	IN	
X23	Temper.	1	IN	TAR Aromatizer Thermocouple
		2	IN	
X24			Lambda sensor	
X25	Boiler level	1	IN/OUT	SL Boiler safety level dection probe
		2	IN/OUT	WL Boiler working level dection probe
		3	IN	REF Boiler level detection probes reference
X27-A		IN/OUT	PMACS communication BUS	
X27-B		IN/OUT	PMACS communication BUS	
X27-C		IN/OUT	PMACS communication BUS	
X27-D		IN/OUT	PMACS communication BUS	
X28-A		IN/OUT	PMACS Recovery communication BUS	
X28-B		IN/OUT	PMACS Recovery communication BUS	
X29	24V	1	IN	+24V dc
		2	IN	
		3	IN	0V dc
		4	IN	
X30	Cavity SSR	1	OUT	KC1 Cavity 1 solid state relay UP
		2	OUT	KC2 Cavity 2 solid state relay UP
		3	OUT	KC3 Cavity 1 solid state relay DOWN
		4	OUT	KC4 Cavity 2 solid state relay DOWN
		5	OUT	0V dc
X31	Boiler SSR	1	OUT	KB1 Boiler 1 solid state relay UP
		2	OUT	KB2 Boiler 2 solid state relay UP
		3	OUT	KB3 Boiler 1 solid state relay DOWN
		4	OUT	KB4 Boiler 2 solid state relay DOWN
		5	OUT	0V dc

Ref.	Group	Pin	Direct.	Function
X32	Cooling Fan 1	1	OUT	FAN1 Cooling fan 1 power supply 24Vdc
		2	IN	FAN1 Cooling fan 1 tachometer sensor
		3	OUT	FAN1 Cooling fan 1 speed control
		4	OUT	FAN1 Cooling fan 1 power supply 0Vdc
X33	Cooling Fan 2	1	OUT	FAN2 Cooling fan 2 power supply 24Vdc
		2	IN	FAN2 Cooling fan 2 tachometer sensor
		3	OUT	FAN2 Cooling fan 2 speed control
		4	OUT	FAN2 Cooling fan 2 power supply 0Vdc
X34	Cooling Fan 3	1	OUT	FAN3 Cooling fan 3 power supply 24Vdc
		2	IN	FAN3 Cooling fan 3 tachometer sensor
		3	OUT	FAN3 Cooling fan 3 speed control
		4	OUT	FAN3 Cooling fan 3 power supply 0Vdc
X35	Vent. Valve	1	OUT	VV1 Venting valve 1 cw rotation
		2	OUT	N
		3	OUT	VV1 Venting valve 1 ccw rotation
X36			-- NOT USE --	
X37	KS	1	OUT	KS Safety contactor
		2		
X38	Smoker	1	OUT	N
		2	OUT	R1 (Smoker heating element)
		3	OUT	
		4	IN	
X39	Flow meter	1	OUT	+24V dc
		2	OUT	FM Flow meter reference
		3	IN	FM Flow meter feedback
X40	Temper.	1	OUT	NCC NTC cabinet components
		2	IN	
		3	OUT	NM8 NTC pump M8
		4	IN	
X41	Temper.	1	OUT	NHSC NTC Cavity SSR heatsink
		2	IN	
X42	Temper.	1	OUT	NHSB NTC Boiler SSR heatsink
		2	IN	
X43	Temper.		-- NOT USE --	
X44	Softner	1	OUT	SSW1 Softner interface
		2	IN	
X45	Switch	1	OUT	24V Reference
		2	IN	DS Door switch
		3	IN	AFS Air filter switch
X46	switch	1	OUT	24V Reference
		2	IN	SVV1 Venting valve CLOSE switch
		3	IN	SVV1 Venting valve OPEN switch
X47		1	OUT	24V Reference
		2	IN	SF Fat drain valve status switch
X48	Switch	1	OUT	24V Reference
		2	IN	DRS Cleaning drawer switch
X49			Recovery Adress	
X50		1	OUT	24V Reference
		2	IN	HER Hood error
		3	IN	
		4	IN	
		5	IN	
X51	Liquid Clean Syst.	1	OUT	P1 Liquid dergent pump
		2	OUT	P2 Liquid rinse pump
		3	OUT	N
X52		1	OUT	HS2 Hood speed 2
		2	OUT	HS1 Hood speed 1
		3	OUT	HON Hood ON
		4	OUT	N Neutral
X53		1	IN	PPM1 Peak power management 1
		2	IN	PPM2 Peak power management 2
X54			-- NOT USE --	

# LOGIC DIAGRAM

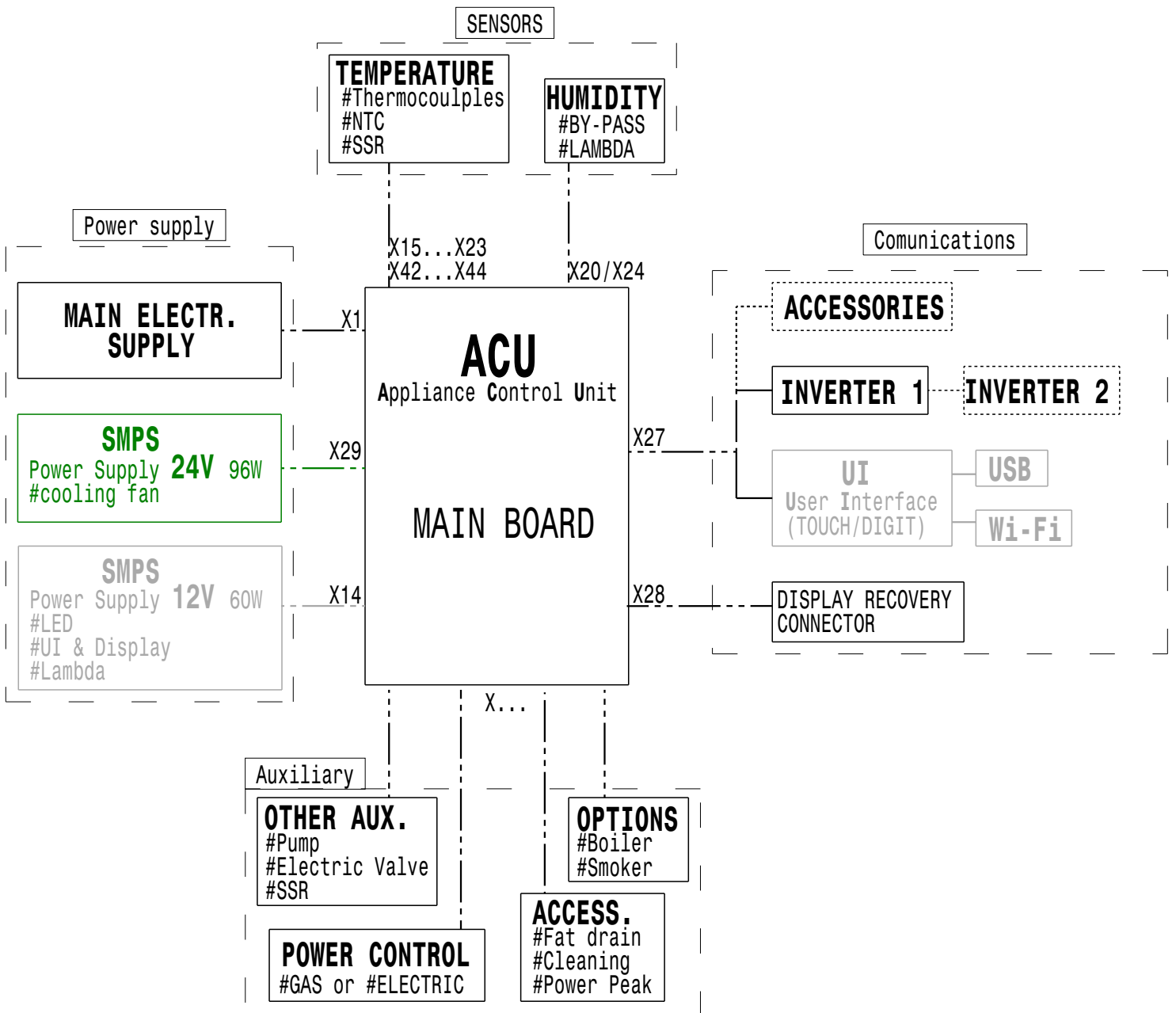

# HARNES DIAGRAM

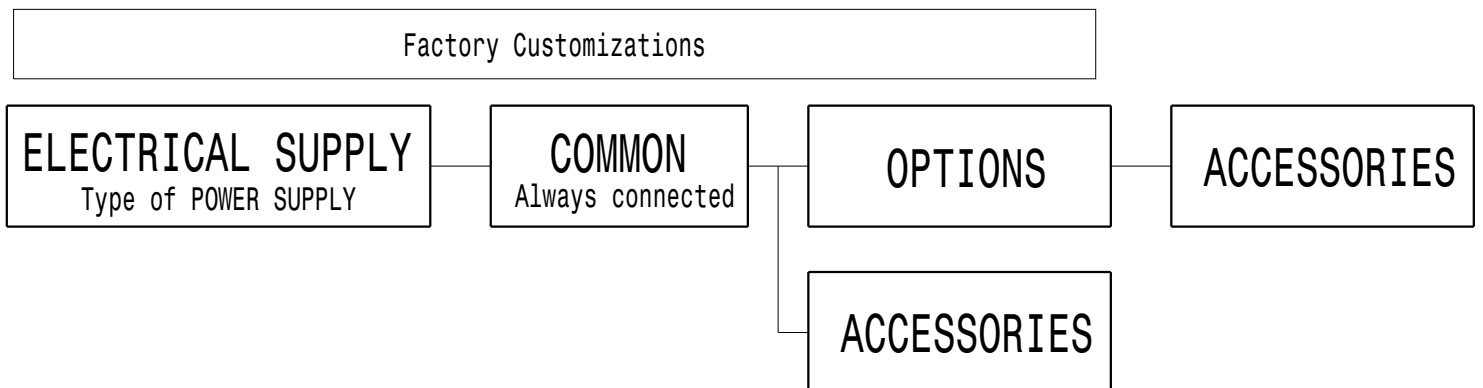

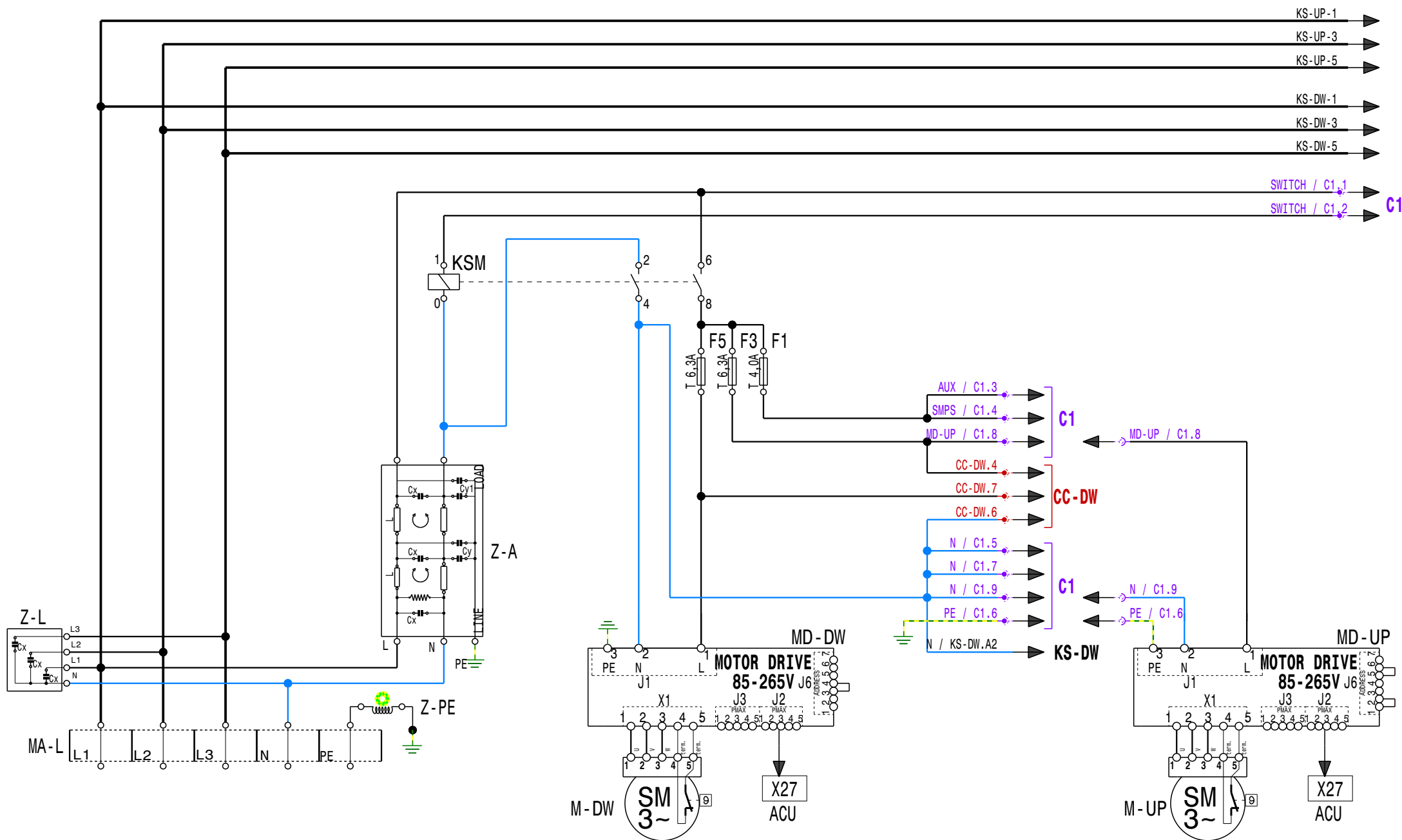

MA-L	TERMINAL BLOCK	Z-A	AUXILIARY FILTER	F1	AUXILIARY FUSE	MD-UP	MOTOR DRIVE UP	MD-DW	MOTOR DRIVE DW
Z-L	CAPACITIVE FILTER	KSM	ON/OFF RELAY	F3	MD-UP FUSE	M-UP	MOTOR UP	M-DW	MOTOR DW
Z-PE	GROUND FILTER	KS	SAFETY CONTACTOR	F5	MD-DW FUSE				

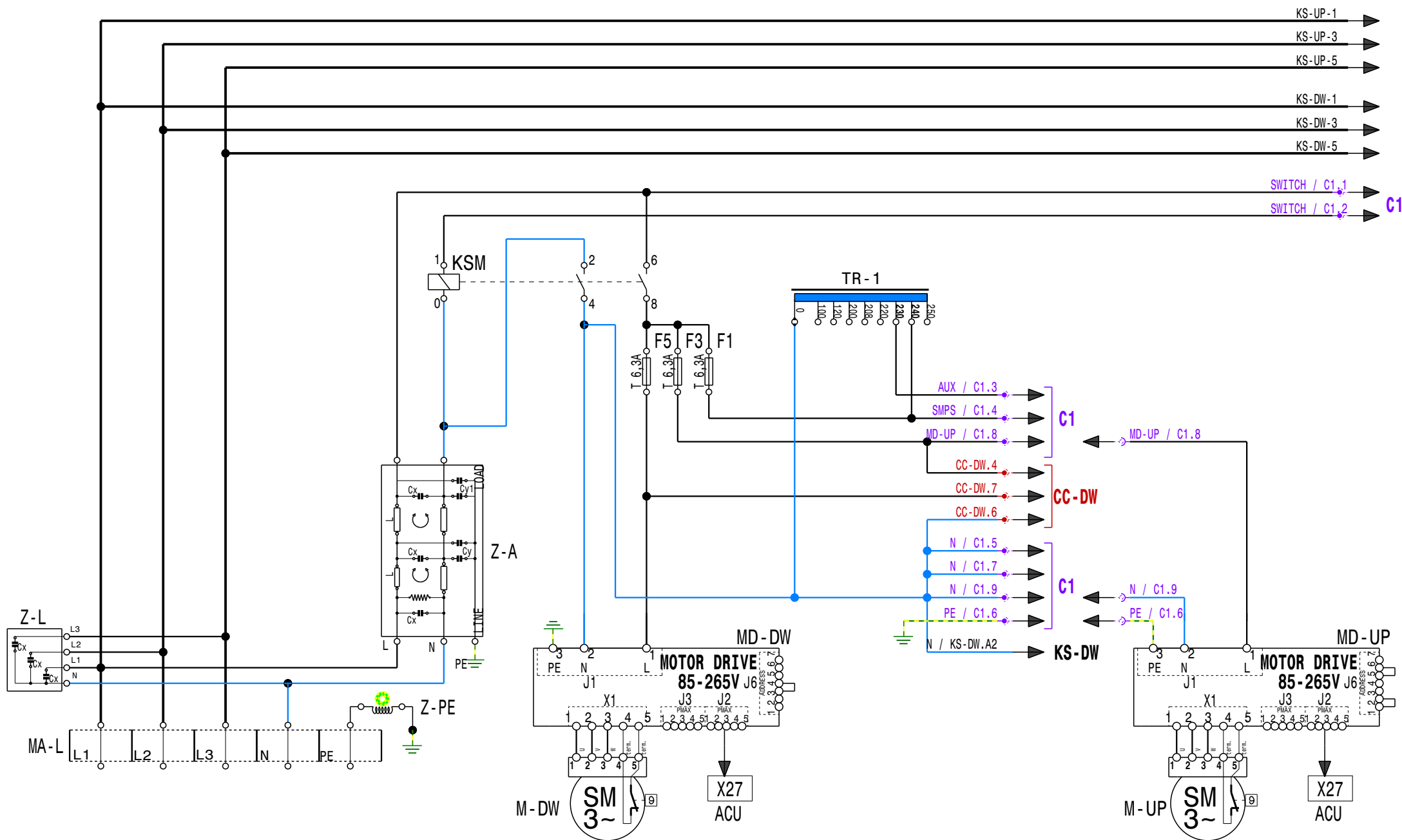

MA-L	TERMINAL BLOCK	Z-A	AUXILIARY FILTER	F1	AUXILIARY FUSE	MD-UP	MOTOR DRIVE UP	MD-DW	MOTOR DRIVE DW	TR-1	TRANSFORMER
Z-L	CAPACITIVE FILTER	KSM	ON/OFF RELAY	F3	MD-UP FUSE	M-UP	MOTOR UP	M-DW	MOTOR DW		
Z-PE	GROUND FILTER	KS	SAFETY CONTACTOR	F5	MD-DW FUSE						

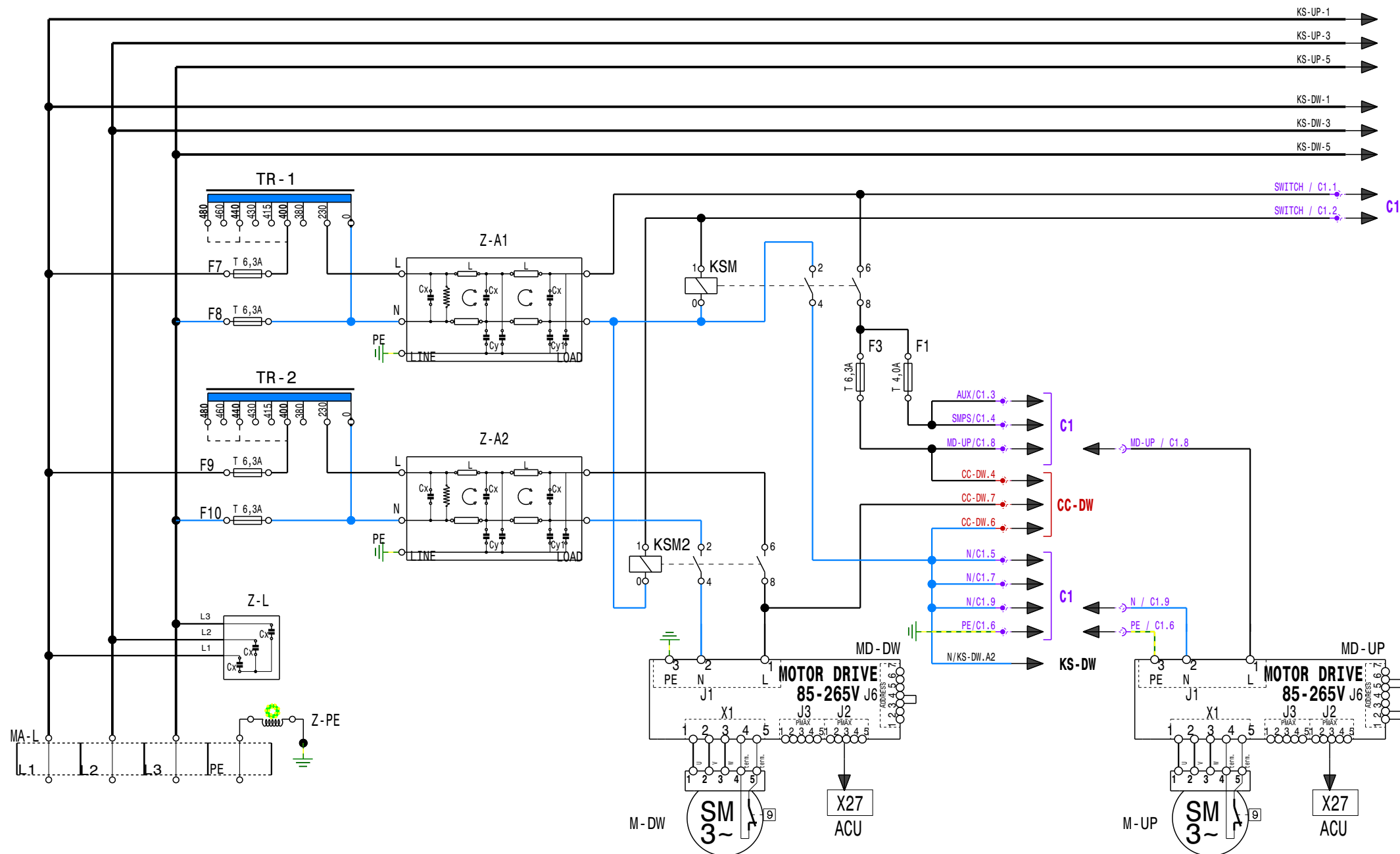

MA-L	TERMINAL BLOCK	KSM	ON/OFF RELAY	KSM2	ON/OFF RELAY 2	F1	AUXILIARY FUSE	MD-DW	MOTOR DRIVE DW	MD-UP	MOTOR DRIVE UP
Z-L	CAPACITIVE FILTER	TR-1	TRANSFORMER 1	F7-F8	TRANSFORMER 1 FUSE	F3	MD-UP FUSE	M-UP	MOTOR UP	M-DW	MOTOR DW
Z-PE	GROUND FILTER	TR-2	TRANSFORMER 2	F9-F10	TRANSFORMER 2 FUSE	COD 602402L04 ELECTRIC DIAGRAM 20 "ELT" 380-480V CKM		From S/N :			
Z-A	AUXILIARY FILTER										

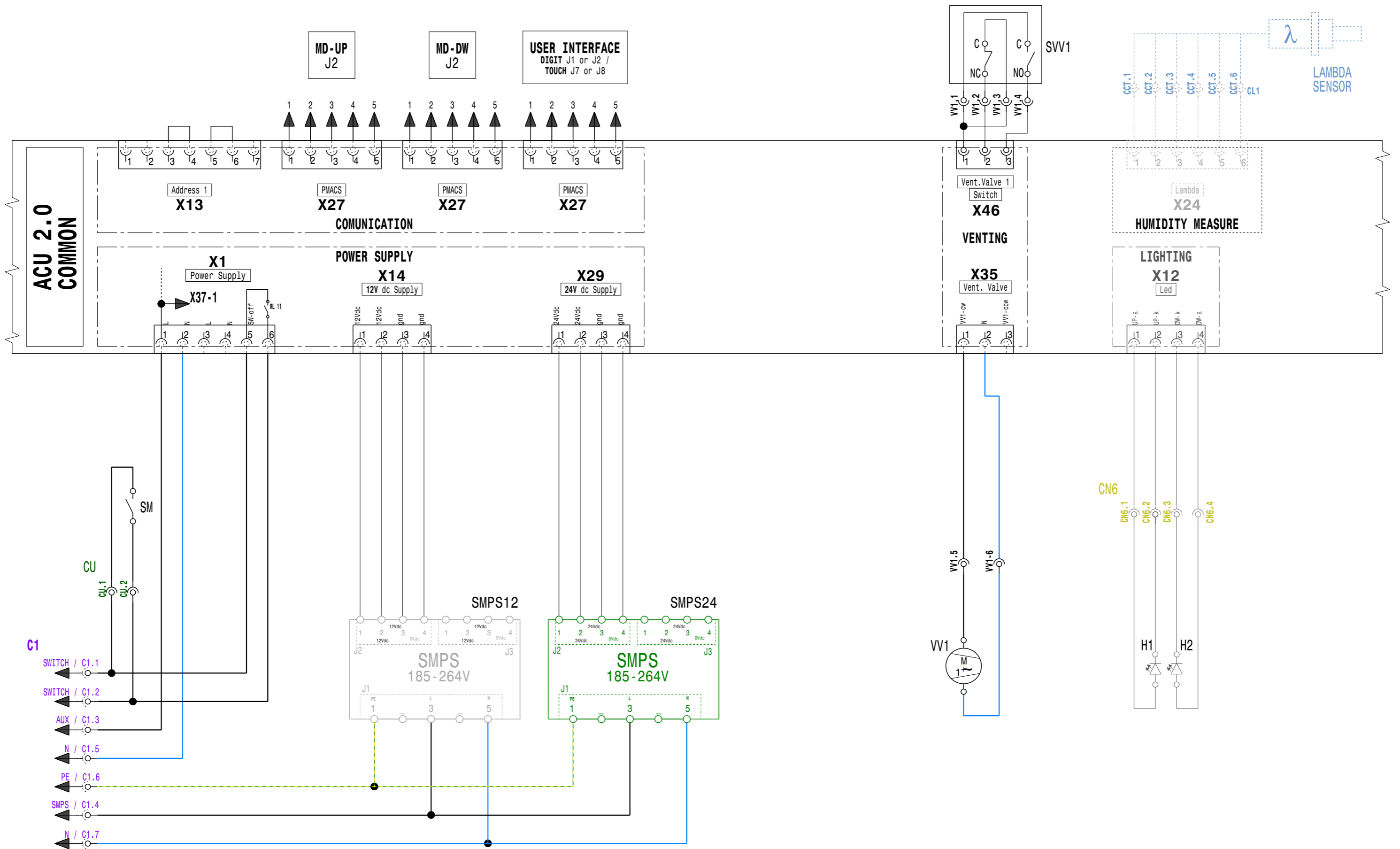

SM	MAIN SWITCH	-	-	SMPS12	SMPS 12V	VV1	VENTING VALVE 1	H1	LED LIGHTING 1	-	-
-	-	-	-	SMPS24	SMPS 24V	SVV1	VENTING VALVE SWITCHES	H2	LED LIGHTING 2	-	-
-	-	-	-	-	-	-	COD 602402L04	ELECTRIC DIAGRAM 20 "ELT" 380-480V CKM			From S/N :

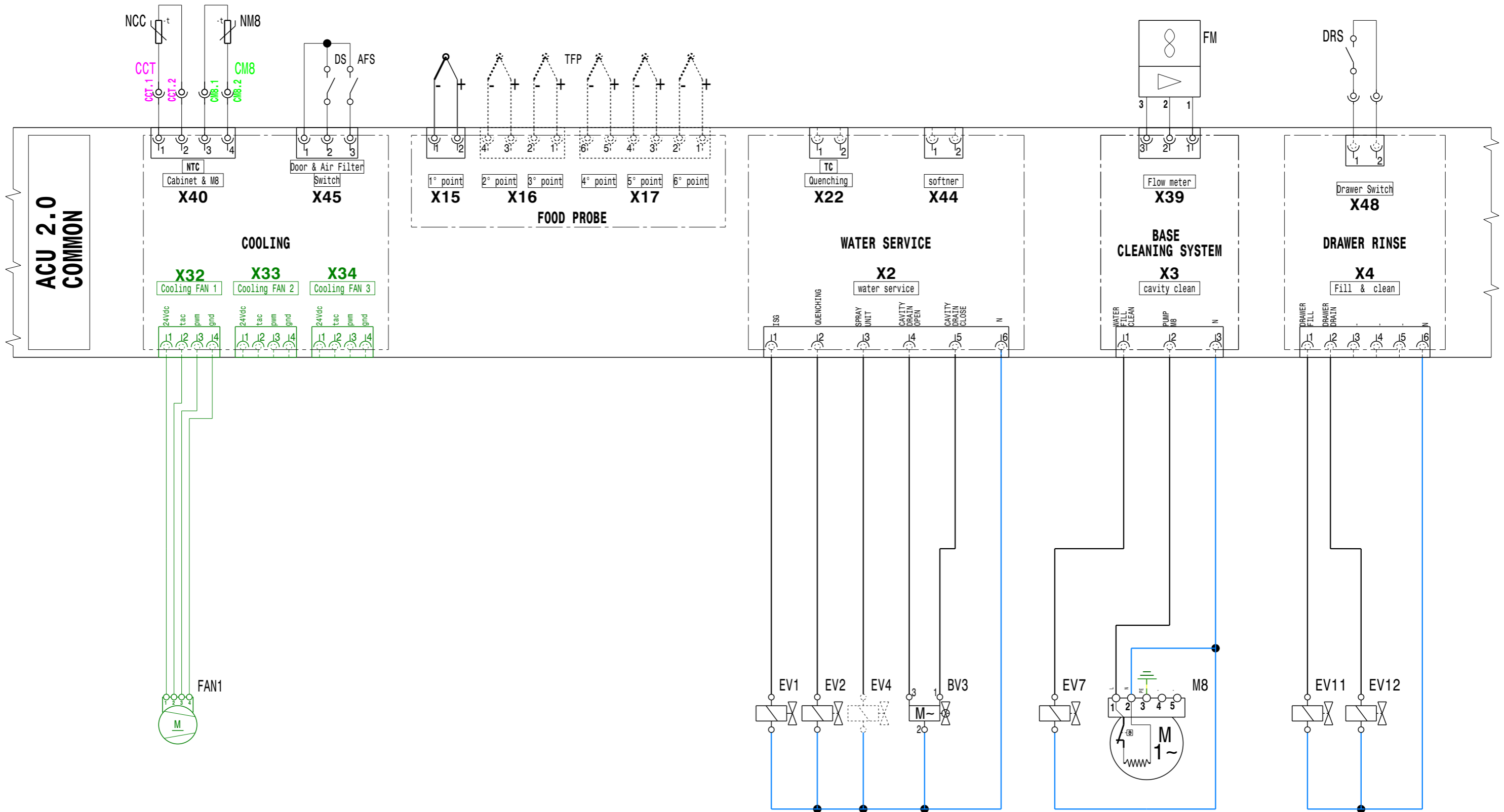

<b>FAN1</b>	COOLING FANS	<b>DS</b>	DOOR SWITCH	<b>TFP</b>	FOOD PROBE TEMPERATURE	<b>FM</b>	FLOW METER	<b>DRS</b>	DRAWER SWITCH
<b>NCC</b>	NTC CABINET COMPONENTS	<b>AFS</b>	AIR FILTER SWITCH	<b>EV1</b>	INSTANT STEAM SOLENOID VALVE	<b>EV7</b>	CLEANING WATER FILL S. VALVE	<b>EV11</b>	DRAWER FILL S. VALVE
<b>NM8</b>	NTC PUMP M8	-	-	<b>EV2</b>	QUENCHING SOL.VALVE	<b>M8</b>	CLEANING PUMP	<b>EV12</b>	DRAWER DRAIN S. VALVE
-	-	-	-	<b>BV3</b>	CAVITY DRAIN BALL VALVE	COD 602402L04   ELECTRIC DIAGRAM 20 "ELT" 380-480V CKM		From S/N :	

# CONVECTION

# "ELECTRIC"

## ELECTRIC CONVECTION

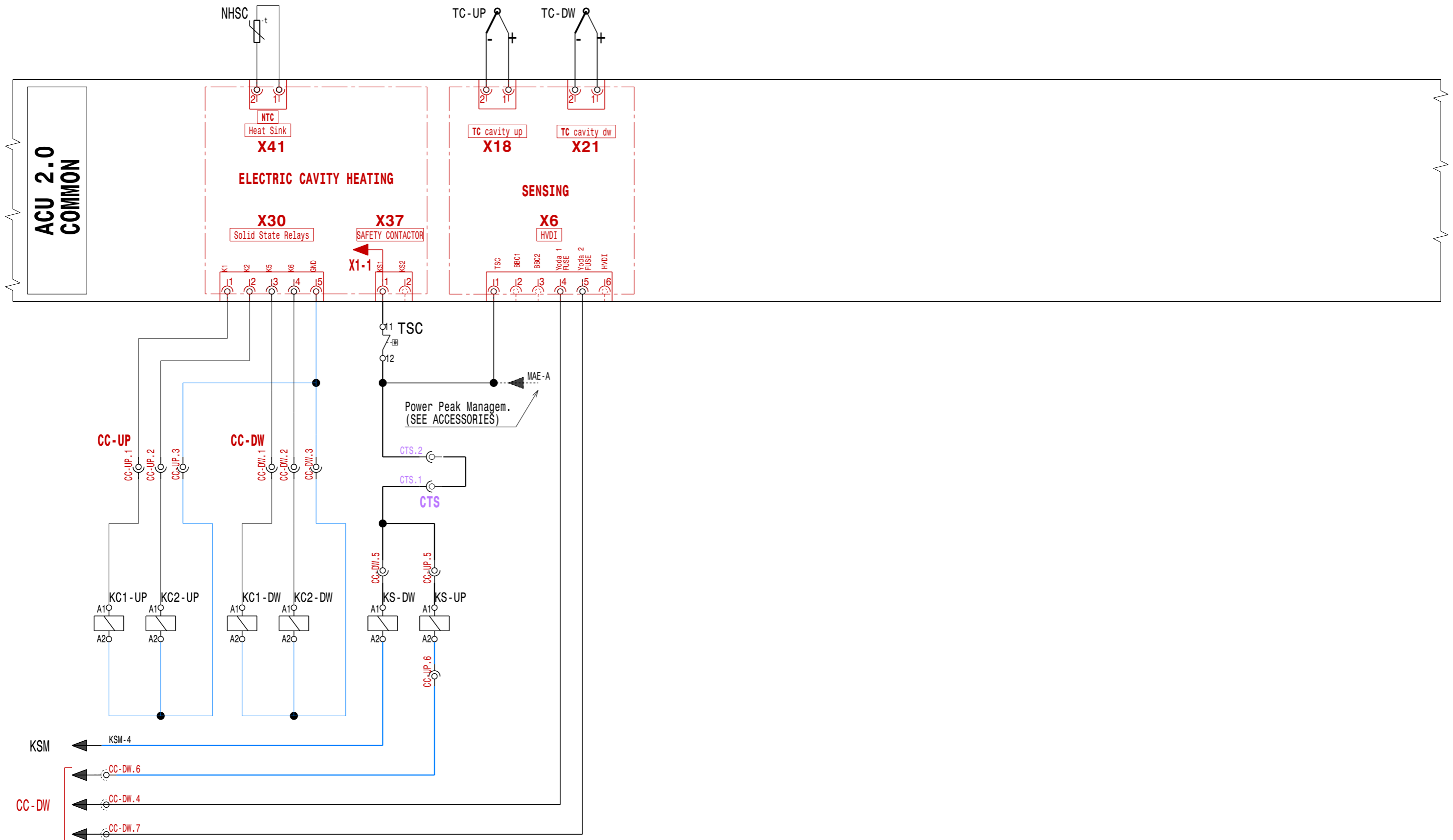

<b>KC1-UP</b>	CAVITY SOLID STATE RELAY 1 UP	<b>KC1-DW</b>	CAVITY SOLID STATE RELAY 1 DOWN	<b>KS-UP</b>	SAFETY CONTACTOR UP	<b>TC-UP</b>	CAVITY UP THERMOCOUPLE
<b>KC2-UP</b>	CAVITY SOLID STATE RELAY 2 UP	<b>KC2-DW</b>	CAVITY SOLID STATE RELAY 2 DOWN	<b>KS-DW</b>	SAFETY CONTACTOR DOWN	<b>TC-DW</b>	CAVITY DOWN THERMOCOUPLE
<b>TSC</b>	CAVITY SAFETY THERMOSTAT	<b>NHSC</b>	NTC CAVITY SSR HEAT SINK	-	-	COD 602402L04   ELECTRIC DIAGRAM 20 "ELT" 380-480V CKM	

From S/N :

# BOILER

# "ELECTRIC"

## ELECTRIC CONVECTION

## ELECTRIC BOILER (OPTION)

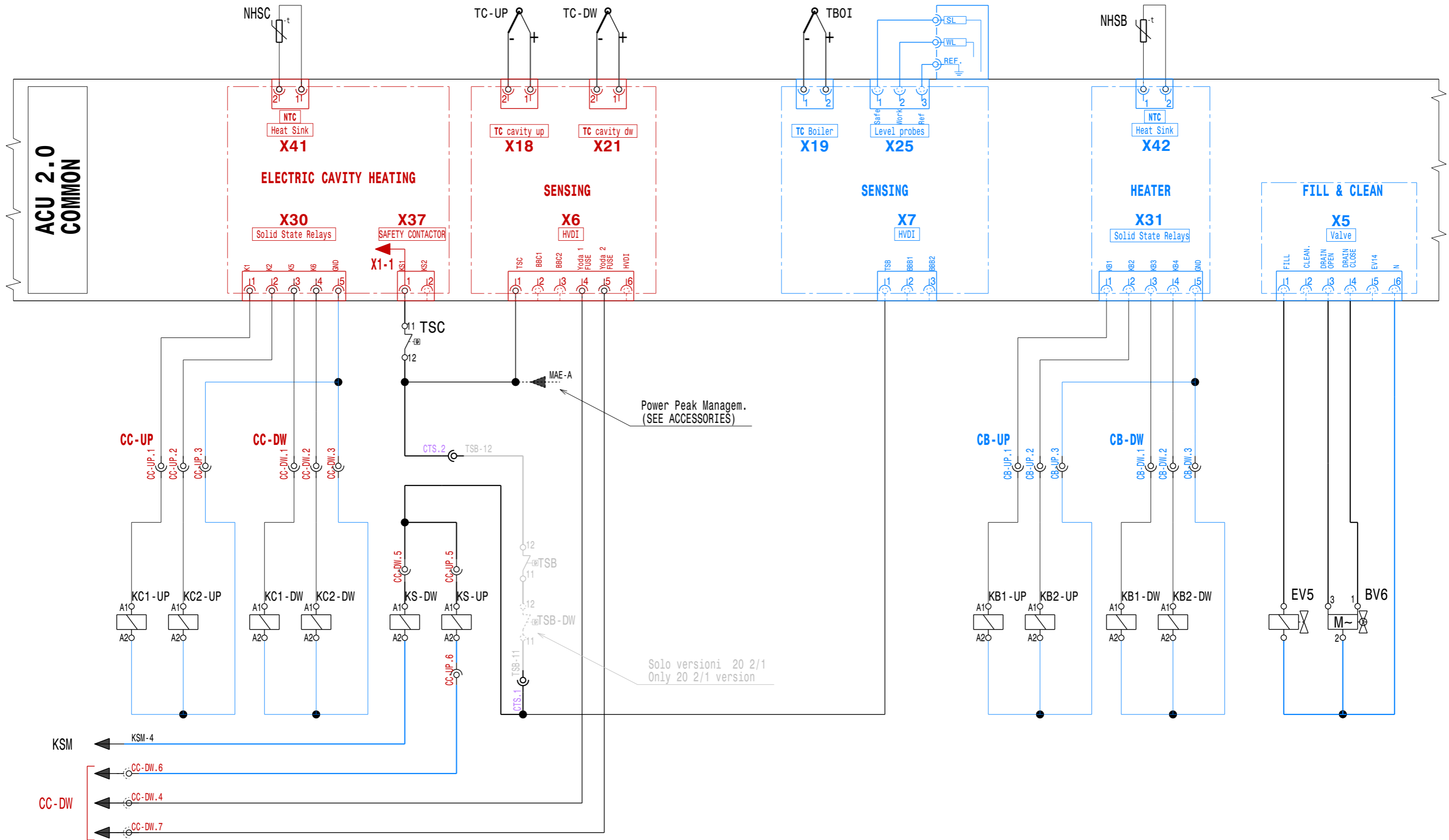

Power Peak Managem.  
(SEE ACCESSORIES)

Solo versioni 20 2/1  
Only 20 2/1 version

<b>KC1-UP</b> CAVITY SSR 1 UP	<b>KS-UP</b> SAFETY CONTACTOR UP	<b>TSC</b> CAVITY SAFETY THERMOSTAT	<b>KB1-UP</b> BOILER SSR 1 UP	<b>KB1-DW</b> BOILER SSR 1 DW	<b>TSB</b> BOILER SAFETY THERMOSTAT
<b>KC2-UP</b> CAVITY SSR 2 UP	<b>KS-DW</b> SAFETY CONTACTOR DOWN	<b>NHSC</b> NTC CAVITY SSR HEAT SINK	<b>KB2-UP</b> BOILER SSR 2 UP	<b>KB2-DW</b> BOILER SSR 2 DW	<b>TBOI</b> BOILER THERMOCOUPLE
<b>KC1-DW</b> CAVITY SSR 1 DOWN	<b>TC-UP</b> CAVITY UP THERMOCOUPLE		<b>EV5</b> BOILER FILL VALVE	<b>BV6</b> BOILER DRAIN BALL VALVE	<b>NHBS</b> NTC BOILER SSR HEAT SINK
<b>KC2-DW</b> CAVITY SSR 2 DOWN	<b>TC-DW</b> CAVITY DOWN THERMOCOUPLE				

## FAT DRAIN SYSTEM

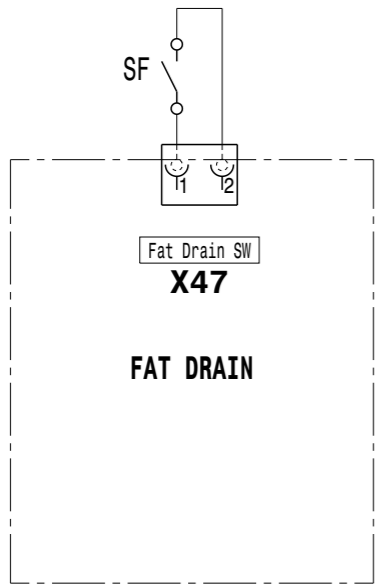

## LIQUID CLEANING

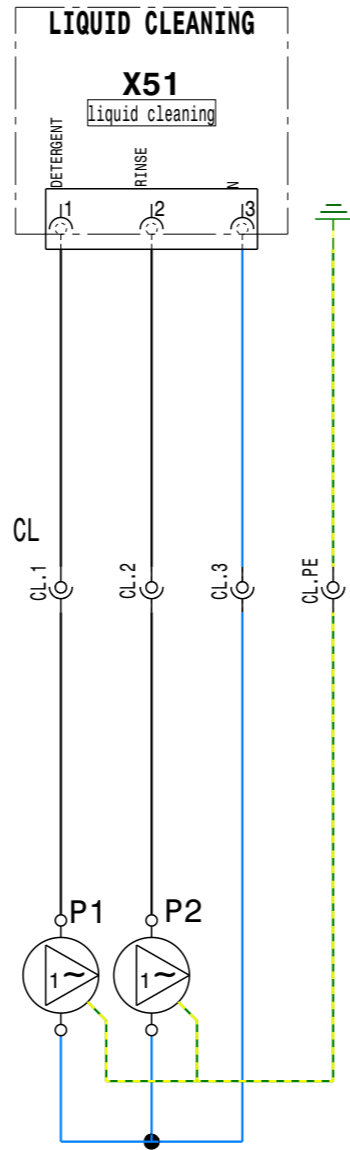

## PEAK POWER MANAGEMENT

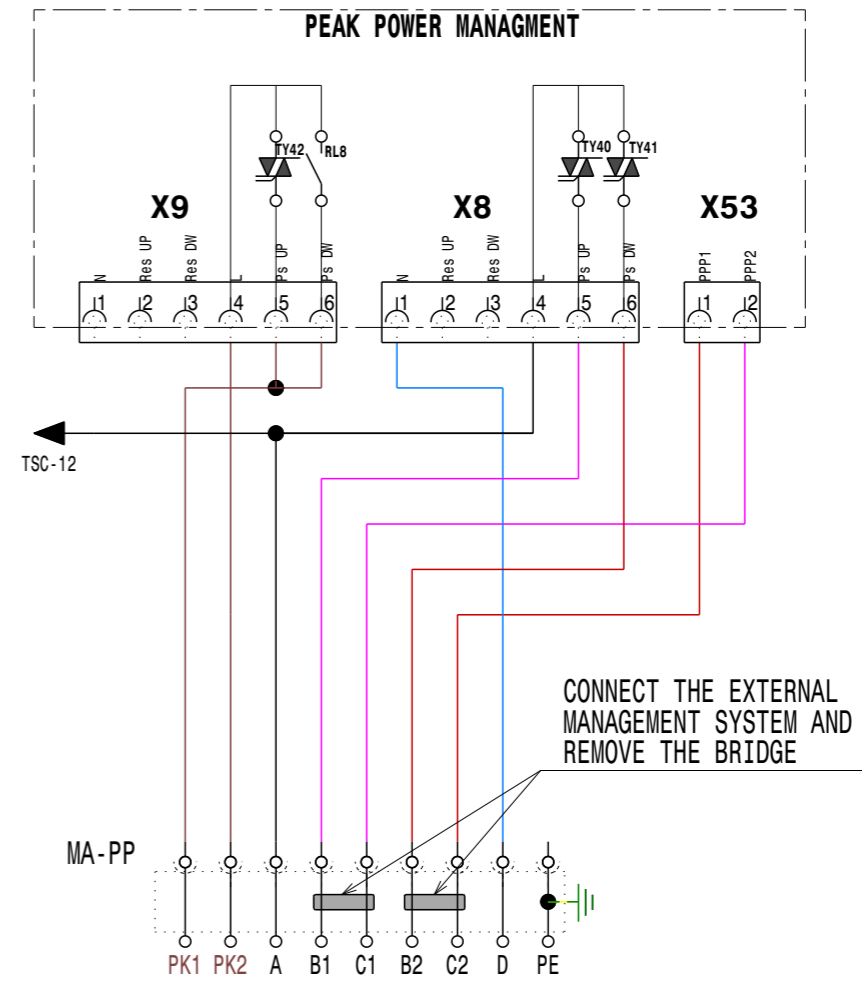

### LEGENDA

- PK: PICK POWER CONTROL (POTENTIAL FREE CONTACT)
- A : POWER ON (KS CLOSED)
- B1: THERMOSTAT ON (HALF AND FULL POWER)
- B2: THERMOSTAT ON (FULL POWER)
- C1: RELEASE HEATING CONTACTOR (FIRST HALF POWER)
- C2: RELEASE HEATING CONTACTOR (SECOND HALF POWER)
- D : REFERENCE POTENTIAL (NEUTRAL)
- PE: GROUND

SF	FAT DRAIN SWITCH	-	-	P1	RINSE PUMP	-	-	MA-PP	TERMINAL BLOCK PEAK POWER MANAGEMENT
-	-	-	-	P2	DETERGENT PUMP	-	-	TSC	CAVITY SAFETY THERMOSTAT
-	-	-	-	-	-	-	-	COD 602402L04   ELECTRIC DIAGRAM 20 "ELT" 380-480V CKM	
									From S/N :

**EXTRACTION HOOD  
CONDENSATION HOOD**

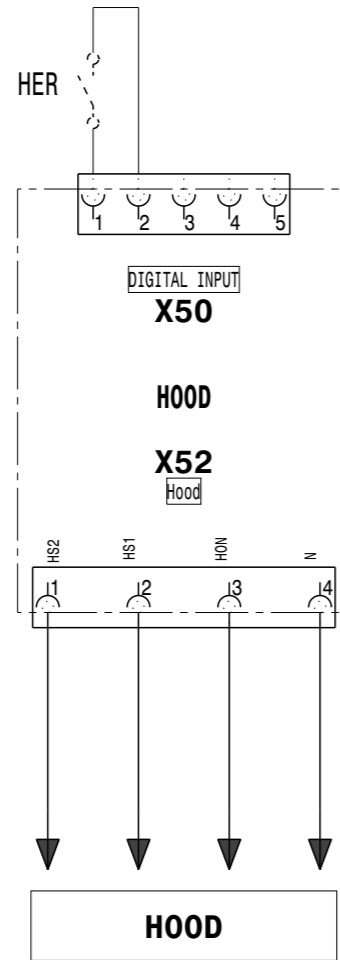

**ODOURLESS HOOD**

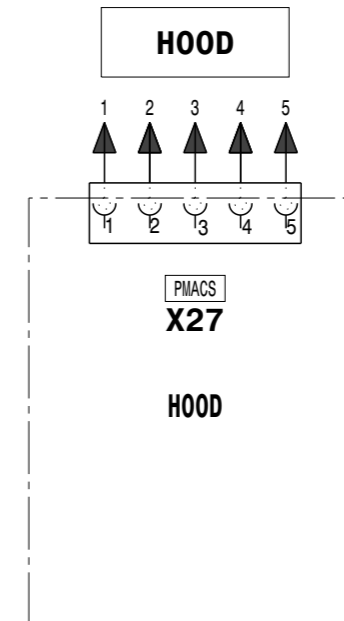

▪	-	▪	-	▪	-	▪	-	▪	-
▪	-	▪	-	▪	-	▪	-	▪	-
▪	-	▪	-	▪	-	▪	-	▪	-
						COD 602402L04   ELECTRIC DIAGRAM 20 "ELT" 380-480V CKM		From S/N :	

BOILER UP

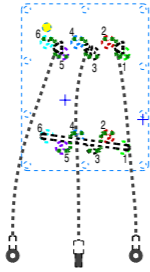

CAVITY UP

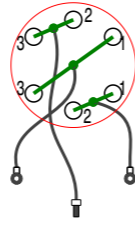

BOILER DOWN

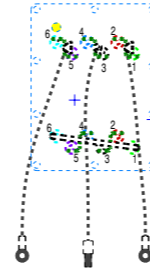

CAVITY DOWN

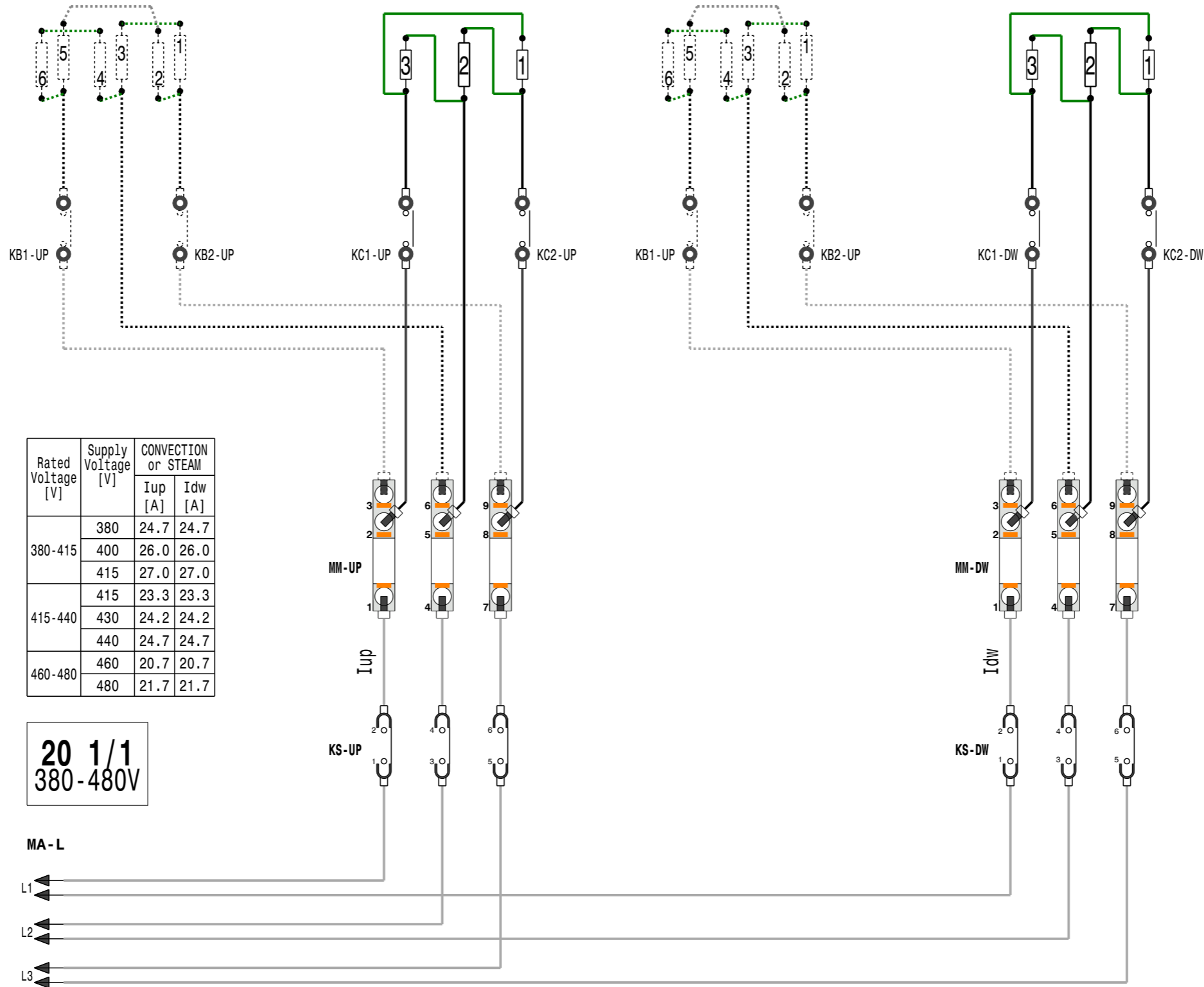
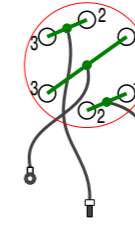

Rated Voltage [V]	Supply Voltage [V]	CONVECTION or STEAM	
		Iup [A]	Idw [A]
380-415	380	24.7	24.7
	400	26.0	26.0
	415	27.0	27.0
415-440	415	23.3	23.3
	430	24.2	24.2
460-480	440	24.7	24.7
	460	20.7	20.7
	480	21.7	21.7

**20 1/1**  
380-480V

MA-L

L1  
L2  
L3

