



MOD : E60/2P3T-N

Production code : F60/30PCE/T

03/2024

PIANO DI COTTURA ELETTRICO
 TABLE DE CUISSON ELECTRIQUE
 ELEKTROKOCHFELD
 ELECTRIC COOKING TOP

MOD.60/30 PCE

CODICE

251.393.00

DATA 19-03-1999

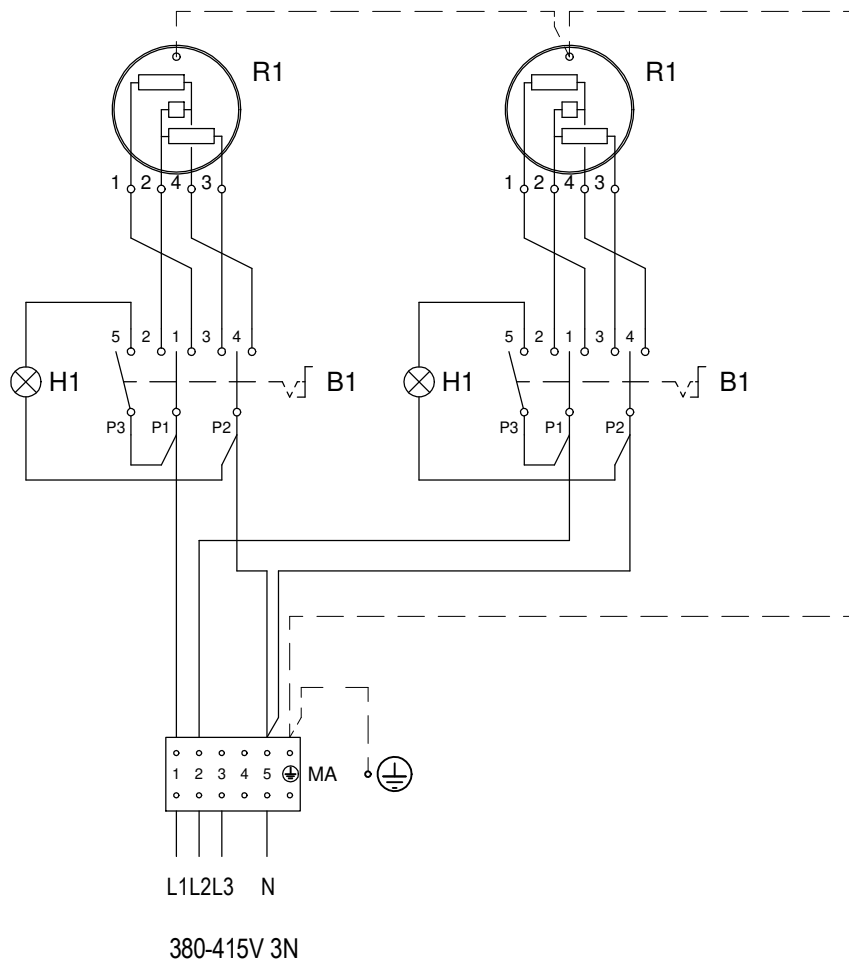

- B1 -COMMUTATORE _ CHANGE-OVER SWITCH
 COMMUTATEUR _ UMSCHALTER
- H1 -LAMPADA SPIA VERDE _ GREEN INDICATOR LIGHT
 LAMPE TEMOIN VERTE _ GRUNE KONTROLLAMPE
- MA -MORSETTIERA ARRIVO LINEA _ POWER INLET TERMINAL BOARD
 BORNES ARRIVEE LIGNE _ ANSCHLUSSBRETT
- R1 -PIASTRA ELETTRICA _ ELECTRIC PLATE
 PLAQUE ELECTRIQUE _ ELEKTROKOCHPLETTE

POTENZA TOTALE - TOTAL POWER
 PUISSANCE TOTALE - ANSCHLUSSWERT

3kW 380-415 V 3N 7A

50-60Hz