



MOD : E22/2ID4T-N

Production code : 393277

01/2026

Induction cooktops

N7E/N9E

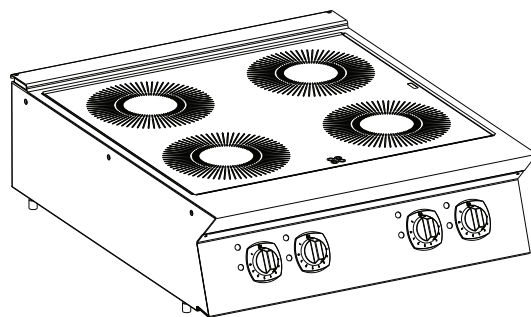

EN Installation and operating manual *

*Original instructions



59589FK02- 2025.03

Foreword

 Read the following instructions, including the warranty terms before installing and using the appliance.

Visit our website www.electroluxprofessional.com and open the Support section to:

 Register your product

 Get hints & tips of your product, service and repair information

The installation, use and maintenance manual (hereinafter Manual) provides the user with information necessary for correct and safe use of the appliance.

The following must not be considered a long and exacting list of warnings, but rather a set of instructions suitable for improving appliance performance in every respect and, above all, preventing injury to persons and animals and damage to property due to improper operating procedures.

All persons involved in appliance transport, installation, commissioning, use and maintenance, repair and disassembly must consult and carefully read this manual before carrying out the various operations, in order to avoid wrong and improper actions that could compromise the appliance's integrity or endanger people. Make sure to periodically inform the user regarding the safety regulations. It is also important to instruct and update personnel authorised to operate on the appliance, regarding its use and maintenance.

The manual must be available to operators and carefully kept in the place where the appliance is used, so that it is always at hand for consultation in case of doubts or whenever required.

If, after reading this manual, there are still doubts regarding appliance use, do not hesitate to contact the Manufacturer or the authorised Service Centre to receive prompt and precise assistance for better operation and maximum efficiency of the appliance. During all stages of appliance use, always respect the current regulations on safety, work hygiene and environmental protection. It is the user's responsibility to make sure the appliance is started and operated only in optimum conditions of safety for people, animals and property.



IMPORTANT

- The manufacturer declines any liability for operations carried out on the appliance without respecting the instructions given in this manual.
- The manufacturer reserves the right to modify the appliances presented in this publication without notice.
- No part of this manual may be reproduced.
- This manual is available in digital format by:
 - contacting the dealer or reference customer care;
 - downloading the latest and up to date manual on the web site www.electroluxprofessional.com;
- The manual must always be kept in an easily accessed place near the appliance. Appliance operators and maintenance personnel must be able to easily find and consult it at any time.

Contents

A	WARNING AND SAFETY INFORMATION	5
A.1	General information	5
A.2	Personal protection equipment	5
A.3	General safety	6
A.4	Induction general safety	6
A.5	Protection devices installed on the appliance	7
A.6	Safety signs to be placed on the appliance or near its area	7
A.7	Reasonably foreseeable improper use	7
A.8	Residual risks	8
A.9	Transport, handling and storage	8
A.10	Installation and assembly	8
A.11	Electrical connection	8
A.12	Positioning	9
A.13	Appliance space limitations	9
A.14	Appliance cleaning	9
A.15	Preventive Maintenance	9
A.16	Parts and accessories	9
A.17	Precautions for use and maintenance	9
A.18	Appliance maintenance	9
A.19	Appliance disposal	10
B	WARRANTY TERMS AND EXCLUSIONS	10
C	TECHNICAL DATA	10
C.1	Dataplate position	10
C.2	Appliance and manufacturer's identification data	10
C.3	Induction models	11
D	GENERAL INFORMATION	11
D.1	Introduction	11
D.2	Intended use and restrictions	11
D.3	Testing and inspection	12
D.4	Copyright	12
D.5	Keeping the manual	12
D.6	Recipients of the manual	12
D.7	Definitions	12
D.8	Responsibility	12
D.9	Customer packaging checks	12
D.10	Storage	12
E	INSTALLATION AND ASSEMBLY	13
E.1	Introduction	13
E.2	Customer's responsibilities	13
E.3	Unpacking instructions	13
E.4	Disposal of packing	13
E.5	Joining Appliances	13
E.5.1	Installation On Bridge or Cantilever Frame (depending on the appliance and/or model)	13
E.5.2	Sealing Gaps Between Appliances	13
E.6	Installation limits	14
E.7	Electrical connection	14
E.7.1	To access the terminal block	14
E.8	Power cable	14
E.9	Equipotential node and Earth connection	14
E.10	Circuit breaker	14
F	NORMAL APPLIANCE USE	14
F.1	Characteristics of personnel enabled to operate on the appliance	14
F.2	Basic requirements for appliance use	15
G	INSTRUCTION FOR THE USER	15
G.1	Choice of pots	15
G.2	Introduction	15
G.2.1	Switching off	15
G.3	Cooking advice	15
G.4	Induction appliances	16
H	APPLIANCE CLEANING AND MAINTENANCE	16
H.1	Care information	16
H.2	Cleaning introduction	16
H.3	Maintenance intervals	16
H.4	Periods of non-use	17
H.5	External parts	17
H.6	Ceramic — glass surfaces	17
H.7	Induction surfaces	17
H.8	Induction full surface air filters	17
H.9	Internal parts (every 6 months)	17
H.10	Warnings	17
H.11	Warnings codes	18

I	TROUBLESHOOTING	18
I.1	Introduction	18
I.2	Inefficiencies detected during cooking	19
J	APPLIANCE DISPOSAL.....	19
J.1	Procedure regarding appliance disposal	19

A WARNING AND SAFETY INFORMATION

A.1 General information

To ensure safe use of the appliance and a proper understanding of the manual it is necessary to be familiar with the terms and typographical conventions used in the documentation. The following symbols are used in the manual to indicate and identify the various types of hazards:



WARNING

Danger for the health and safety of operators.



WARNING

Danger of electrocution - dangerous voltage.



CAUTION

Risk of damage to the appliance or the product.



WARNING

Danger of magnetic fields.



IMPORTANT

Important instructions or information on the product



Equipotentiality



Read the instructions before using the appliance







Clarifications and explanations

- Only specialised personnel are authorised to operate on the appliance.
- This appliance is to be intended for commercial and collective use, for example in kitchens of restaurants, canteens, hospitals and in commercial enterprises such as bakeries, butcheries, etc., not for continuous mass production of food. Any other use is deemed improper.
- This appliance is intended to be used in professional areas (eg. bar, canteen, etc) by an operator for normal appliance use.
- This appliance must not be used by minors and adults with limited physical, sensory or mental abilities or without adequate experience and knowledge regarding its use.
- Do not let children play with the appliance.
- Keep all packaging and detergents away from children.
- Cleaning and user maintenance shall not be made by children without supervision.
- For your safety do not store or use gasoline or other flammable materials, vapours and liquids in the vicinity of this or any other appliance.
- Do not store explosive substances, such as pressurized containers with flammable propellant, in this appliance.
- Refer to the data given on the appliance's data plate for relations with the Manufacturer (e.g. when ordering spare parts, etc.).
- When scrapping the appliance, the marking CE must be destroyed.
- Save these instructions carefully for further consultation by the various operators.

A.2 Personal protection equipment

Summary table of the Personal Protection Equipment (PPE) to be used during the various stages of the appliance's service life.

Stage	Protective garments	Safety footwear	Gloves	Glasses	Safety helmet
Transport	—	●	○	—	○
Handling	—	●	○	—	—
Unpacking	—	●	○	—	—
Installation	—	●	● ¹	—	—
Normal use	●	●	● ²	—	—
Adjustments	○	●	—	—	—
Routine cleaning	○	●	● ¹⁻³	○	—

Stage	Protective garments	Safety footwear	Gloves	Glasses	Safety helmet
					
Extraordinary cleaning	○	●	● ¹⁻³	○	—
Maintenance	○	●	○	—	—
Dismantling	○	●	○	○	—
Scrapping	○	●	○	○	—
Key:					
●	PPE REQUIRED				
○	PPE AVAILABLE OR TO BE USED IF NECESSARY				
—	PPE NOT REQUIRED				

1. During these operations, gloves must be cut-resistant. Failure to use the personal protection equipment by operators, specialized personnel or users can involve exposure to harm to health (depending on the model).

2. During these operations, gloves must be heatproof to protect hands from contact with hot food or hot parts of the appliance and/or when removing hot items from it. Failure to use the personal protection equipment by operators, specialised personnel or users can involve exposure to chemical risk and cause possible harm to health (depending on the model).

3. During these operations, gloves must be suitable for contact with chemical substances used (refer to the safety data sheet of the substances used for information regarding the required PPE). Failure to use the personal protection equipment by operators, specialized personnel or users can involve exposure to chemical risk and cause possible harm to health (depending on the model).

A.3 General safety

- The appliances are provided with electric and/or mechanical safety devices for protecting workers and the appliance itself.
- Never operate the appliance, removing, modifying or tampering with the guards, protection or safety devices.
- Do not make any modifications to the parts supplied with the appliance.
- Several illustrations in the manual show the appliance, or parts of it, without guards or with guards removed. This is purely for explanatory purposes. Do not use the appliance without the guards or with the protection devices deactivated.

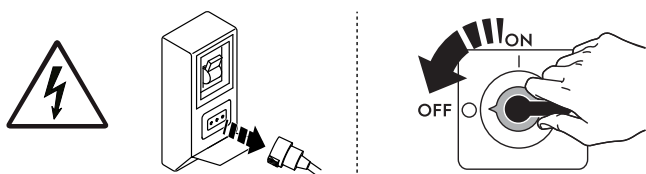

Disconnect the appliance from the power supply before carrying out any installation, assembly, cleaning or maintenance procedure.

- Do not remove, tamper with or make illegible the CE marking, the safety, danger and instruction signs and labels on the appliance.
- The A-weighted emission sound pressure level does not exceed 70 dB(A).
- Do not use products (even if diluted) containing chlorine (sodium hypochlorite, hydrochloric or muriatic acid, etc.) to clean the appliance or the floor under it.
- Do not spray aerosols in the vicinity of this appliance while it is in operation.
- Install the appliance under conditions of adequate ventilation in order to provide a suitable air change per hour. Make sure that the ventilation system, whatever it is, always remains operational and efficient for the entire period of time during which the equipment is operating.
- The following operations have to be carried out by specialised authorised personnel or Customer Care Service provided with all the appropriate personal protection equipment (A.2 *Personal protection equipment*), tools, utensils and ancillary means, who can ask the manufacturer to supply a servicing manual:
 - Installation and assembly
 - Positioning
 - Electrical connection
 - Appliance cleaning, repair and extraordinary maintenance
 - Appliance disposal
 - Work on electrical equipment

A.4 Induction general safety

- The hotplate cannot be cooled with direct jets of water, intentional or accidental (e.g. when filling pots with water from a side pourer or spill onto the hot-plate).
- The glass-ceramic top could be damaged due to punctiform impacts (e.g. falling of metal object on the surface) or hard handling of the pots.
- If the surface is damaged or cracked, immediately disconnect the appliance or appropriate part of the appliance from the supply.
- During every normal cooking process the glass-ceramic top is very hot and therefore must not be touched (burns danger).
- During every normal cooking process must not be left empty pans onto the glass-ceramic top (overheating danger).
- During every normal cooking process do not place paper, cardboard, cloths, etc., between the pot and the glass-ceramic top (risk of fire).
- During every normal cooking process no other object (e.g. plastic vessels, closed tinned foods, aluminium foil, cutlery or other metal objects) except pots, must be placed on the hotplate (burns danger). The hotplate must not be used as a rest surface.

- If a splashguard device is used for cooking, it must not have a metal surface.
- During every normal cooking process, objects such as rings, watches, etc., worn by the user can become very hot if brought near the surface of the appliance (burns danger).
- **Anyone fitted with a pacemaker or other metal implants can suffer life-threatening injuries when using induction appliances.** Ask the manufacturer of your implant or consult your doctor about possible risks before using the cooker.
- Every kind of objects that react to magnetisation (e.g. credit cards, telephone cards, etc.) must not be placed near or above the glass-ceramic top.
- The induction appliance has internal air cooling. The air intake and outlet openings located under the appliance must not be blocked with objects or cloths (overheating danger).
- At the end of cooking always switch off the cooking zones.
- It is advisable to use pots specially designed for this induction appliance (refer to G.1 *Choice of pots*), otherwise the appliance may malfunction or become damaged.
- To guarantee continuous operation at maximum power, the room temperature must be below 40°C.







A.5 Protection devices installed on the appliance

Guards

The appliance has:

- fixed guards (e.g. casings, covers, side panels, etc.), fixed to the appliance and/or frame with screws or quick-release connectors that can only be removed or opened with tools; therefore the user must not remove or tamper with such devices. The Manufacturer declines any liability for damage due to tampering or their non-use;
- interlocked movable guards (door) for access inside the appliance;
- appliance electrical equipment access panels or doors, made from hinged panels openable with tools. The panel or the door must not be opened when the appliance is connected to the power supply.

A.6 Safety signs to be placed on the appliance or near its area

Prohibition	Meaning
	do not remove the safety devices
	do not use water to extinguish fires (placed on electrical parts)
	Keep the area around the appliance clear and free from combustible materials. Do not keep flammable materials in the vicinity of the appliance
	access forbidden to wearers of electrical stimulator (pacemakers)
Danger	Meaning
	caution hot surface
	danger of electrocution (shown on electrical parts with indication of voltage)
	risk of electromagnetic fields

A.7 Reasonably foreseeable improper use

Improper use is any use different from that specified in this manual. During appliance operation, other types of work or activities deemed improper and that in general can involve risks for the safety of operators and damage to the appliance are not allowed. Reasonably foreseeable improper use includes:

- lack of appliance maintenance, cleaning and periodical checks;
- structural changes or modifications to the operating logic;
- tampering with the guards or safety devices;
- failure to use personal protection equipment by operators, specialised personnel and maintenance personnel;

- failure to use suitable accessories (e.g. use of unsuitable equipment or ladders);
- keeping combustible or flammable materials, or in any case materials not compatible with or pertinent to the work, near the appliance;
- wrong appliance installation;
- placing in the appliance any objects or things not compatible with its use, or that can damage the appliance, cause injury or pollute the environment;
- climbing on the appliance;
- non-compliance with the requirements for correct appliance use;
- other actions that give rise to risks not eliminable by the Manufacturer.

A.8 Residual risks

The appliance has several risks that were not completely eliminated from a design standpoint or with the installation of adequate protection devices. Nevertheless, through this manual the Manufacturer has taken steps to inform operators of such risks, carefully indicating the personal protection equipment to be used by them. In order to reduce the risks, provide for sufficient spaces while installing the unit.

To preserve these conditions, the areas around the appliance must always be:

- kept free of obstacles (e.g. ladders, tools, containers, boxes, etc.);
- clean and dry;
- well lit.

For the Customer's complete information, the residual risks remaining on the appliance are indicated below: such actions are deemed improper and therefore strictly forbidden.

Residual risk	Description of hazardous situation
Slipping or falling	The operator can slip due to water, any liquid or dirt on the floor
Burns/abrasions (e.g. heating elements, cold pan, cooling circuit plates and pipes)	The operator deliberately or unintentionally touches some components inside the appliance without using protective gloves.
Electrocution	Contact with live parts during maintenance operations carried out with the electrical panel powered
Crushing or injury	The specialised personnel may not correctly fix the control panel when accessing the technical compartment. The panel could close suddenly.
Tipping of loads	When handling the appliance or the packing containing it, using unsuitable lifting systems or accessories or with the unbalanced load
Chemical	Contact with chemical substances (e.g. detergent, rinse aid, scale remover, etc.) without taking adequate safety precautions. Therefore always refer to the safety cards and labels on the products used.
Sudden closure	The operator for normal appliance use could suddenly and deliberately close the lid/door/oven door (if present, depending on the appliance type).

A.9 Transport, handling and storage

- Transport (i.e. transfer of the appliance from one place to another) and handling (i.e. transfer inside workplaces) must occur with the use of special and adequate means.
- Please refer to indications on packaging for stackability during transport, handling and storage.
- Do not stand under suspended loads during loading or unloading operations. Unauthorized personnel must not enter the work area.
- The weight of the appliance alone is not sufficient to keep it steady.
- For appliance handling, do not lift and anchor it to movable or weak parts such as: casings, electrical raceways, pneumatic parts, etc.
- Do not push or pull the appliance to move it, as it may tip over. Use proper tool to lift the appliance.
- Arrange a suitable area with flat floor for appliance unloading and storage operations.
- Appliance transport, handling, shifting and storage personnel must be adequately instructed and trained regarding the safely use of lifting systems and personal protection equipment suitable for the type of operation carried out.
- When removing the anchoring systems, make sure the stability of the appliance parts does not depend on the anchoring and, therefore, that this operation does not cause the load to fall off the vehicle. Before unloading the appliance components, make sure all the anchoring systems are removed.

A.10 Installation and assembly

- The operations described must be carried out in compliance with the current safety regulations and provisions in force in the country of use.
- The plug, if present, must be accessible after positioning the appliance in the place of installation.
- The appliance is not suitable for installation outdoors and/or in places exposed to atmospheric agents (rain, direct sunlight, etc.).

A.11 Electrical connection

- The power supply system must be suitable for the rated current of the connected appliance; the connection must be carried out in compliance with the regulations and provisions in force in the country of use.
- The information regarding the appliance power supply voltage and frequency is given on the data plate.

- Install between the power cable and the electric line a differential thermal-magnetic switch suitable for the absorption specified on the data plate, with contact gap enabling complete disconnection in category III overvoltage conditions and complying with the regulations in force.
- If the power cable is damaged or too short, it must be replaced by the Customer Care Service or in any case by specialised personnel, in order to prevent any risk.
- The manufacturer declines any liability for damage or injury resulting from breach of the above rules or non-compliance with the electrical safety regulations in force in the country where the appliance is used.
- Verify that a safety circuit breaker is installed between the power cable of the appliance and the mains electric line. The contact opening max. distance and leakage current must comply with the local safety regulations.
- If present, connected the appliance to the equipotential protection circuit ∇ .

A.12 Positioning

- Install the appliances, taking all the safety precautions required for this type of operation, also respecting the relevant fire-prevention measures.
- Prevent the areas where the appliance is installed to be polluted with corrosive substances (chlorine, etc.). The manufacturer declines any liability for corrosive effects due to external causes.
- The appliance can be installed separately or combined only with other appliances of the same range.

A.13 Appliance space limitations

- The appliances are not suitable for recess-mounting. Leave a space of at least 250 between the appliance and side walls and 100 from the rear wall, or in any case an adequate space to enable subsequent servicing or maintenance operations.
- Maintain a distance of at least 250 mm between the appliance and any combustible walls.

A.14 Appliance cleaning

- Do not touch the appliance with wet hands or feet or when barefoot.
- Put the appliance in safe conditions before starting any cleaning operation.
- Do not allow oil or grease to come into contact with plastic parts. Do not allow dirt, fat, food or other residuals to form deposits on the appliance.
- Respect the requirements for the various routine and extraordinary maintenance operations. Non-compliance with the instructions can create risks for personnel.
- Do not spray water or use water jets, steam cleaner or high pressure cleaner.

A.15 Preventive Maintenance

In order to ensure the safety and performance of your equipment, it is recommended that service is undertaken by authorised engineers every 12 months, in accordance with Service Manuals. Please contact your local Service Centre for further details.

A.16 Parts and accessories

Use only original accessories and/or spare parts. Failure to use original accessories and/or spare parts will invalidate the original manufacturer warranty and may render the appliance not compliant with the safety standard.

A.17 Precautions for use and maintenance

- Risks mainly of a mechanical, thermal and electrical nature exist in the appliance. Where possible the risks have been neutralised:
 - directly, by means of adequate design solutions.
 - indirectly by using guards, protection and safety devices.
- Any anomalous situations are signalled on the control panel display.
- During maintenance several risks remain, as these could not be eliminated, and must be neutralised by adopting specific measures and precautions.
- Do not carry out any checking, cleaning, repair or maintenance operations on moving parts. Workers must be informed of this prohibition by means of clearly visible signs.
- Make sure to periodically check correct operation of all the safety devices and the insulation of electrical cables, which must be replaced if damaged.

In case of a significant anomaly (e.g. short circuits, wires coming out of the terminal block, motor breakdowns, worn electrical cable sheathing, etc.) the operator for normal appliance use must:

- immediately deactivate the appliance and disconnect all the supplies (electricity, gas, water).

A.18 Appliance maintenance

- The inspection and maintenance intervals depend on the actual appliance operating conditions and ambient conditions (presence of dust, damp, etc.), therefore precise time intervals cannot be given. In any case, careful and periodical appliance maintenance is advisable in order to minimise service interruptions.
- It is advisable to stipulate a preventive and scheduled maintenance contract with the Customer Care Service.
- Put the appliance in safe conditions before starting any maintenance operation.
- To guarantee appliance efficiency and correct operation, periodical maintenance must be carried out according to the instructions given in the manual.

A.19 Appliance disposal

- Make the appliance unusable by removing the power cable and any compartment closing devices, to prevent the possibility of someone becoming trapped inside.

B WARRANTY TERMS AND EXCLUSIONS

If the purchase of this product includes warranty coverage, warranty is provided in line with local regulations and subject to the product being installed and used for the purposes as designed, and as described within the appropriate equipment documentation.

Warranty will be applicable where the customer has used only genuine spare parts and has performed maintenance in accordance with user and maintenance documentation made available in paper or electronic format.

strongly recommends using approved cleaning, rinse and descaling agents to obtain optimal results and maintain product efficiency over time.

The warranty does not cover:

- service trips cost to deliver and pick up the product;
- installation;
- training on how to use/operate;
- replacement (and/or supply) of wear and tear parts unless resulting from defects in materials or workmanship reported within one (1) week from the failure;
- correction of external wiring;
- correction of unauthorized repairs as well as any damages, failures and inefficiencies caused by and/or resulting from:
 - insufficient and/or abnormal capacity of the electrical systems (current/voltage/frequency, including spikes and/or outages);
 - inadequate or interrupted water supply, steam, air, gas (including impurities and/or other that does not comply with the technical requirements for each appliance);
 - plumbing parts, components or consumable cleaning products that are not approved by the manufacturer;

- customer's negligence, misuse, abuse and/or non-compliance with the use and care instructions detailed within the appropriate equipment documentation;
 - improper or poor: installation, repair, maintenance (including tampering, modifications and repairs carried out by third parties not authorized) and modification of safety systems;
 - Use of non-original components (e. g.: consumables, wear and tear, or spare parts);
 - environment conditions provoking thermal (e. g. overheating/freezing) or chemical (e. g. corrosion/oxidation) stress;
 - foreign objects placed in- or connected to- the product;
 - accidents or force majeure;
 - transportation and handling, including scratches, dents, chips, and/or other damage to the finish of the product, unless such damage results from defects in materials or workmanship and is reported within one (1) week of delivery unless otherwise agreed;
- product with original serial numbers that have been removed, altered or cannot be readily determined;
 - replacement of light bulbs, filters or any consumable parts;
 - any accessories and software not approved or specified by.

warranty will be void and manufacturer shall have no liability related thereto in case of any modification of the product or related hardware/software/programming.

Warranty does not include scheduled maintenance activities (including the parts required for it) or the supply of cleaning agents unless specifically covered within any local agreement, subject to local terms and conditions.

Check on website the list of authorized customer care.

C TECHNICAL DATA

C.1 Dataplate position



IMPORTANT

This instruction manual contains information relevant to various appliances; see the dataplate to identify it.

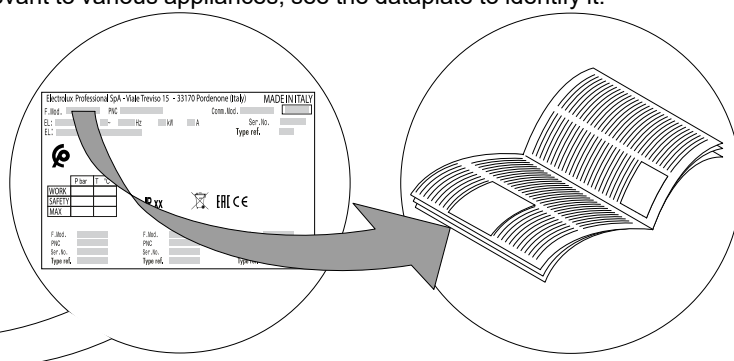
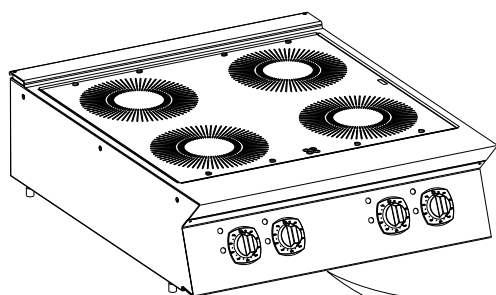

IMPORTANT

When installing the appliance, make sure the electrical connection is carried out in compliance with that specified on the data plate.

C.2 Appliance and manufacturer's identification data

The data plate gives the product identification and technical data.

An example of the marking or data plate on the appliance is given below:

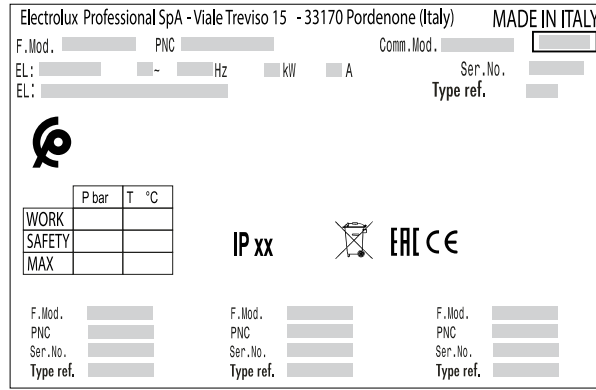

The meaning of the various information given on it is listed below:

F.Mod.	factory description of product
Comm.Mod.	commercial description
PNC	production number code
Ser.No.	serial number
Type ref.	certification group of the appliance
V	power supply voltage
Hz	power supply frequency
kW	power input
A	absorbed current
CE	CE marking
	WEEE symbol
IPX5	dust and water protection rating

C.3 Induction models

TYPE	Hotplates	Nominal max. Power	Power supply cable section ¹
	Nr.	kW	mm ²
N7CIN 400 mm	1	5	2.5
IH720 400 mm	2	7	2.5
IH740 800 mm	4	14	4
IH72P 800 mm	2	10	2.5
IH74P 800 mm	4	20	6

1. Minimum recommended.

TYPE	Hotplates	Nominal max. Power	Power supply cable section ¹
	Nr.	kW	mm ²
N9CIN 400 mm	1	5	2.5
IH920 400 mm	2	10	2.5
IH940 800 mm	4	20	6

1. Minimum recommended.

D GENERAL INFORMATION



WARNING

Refer to “*WARNING and Safety Information*”.

but are not intended to be a detailed representation of the appliance supplied.

The numerical values given on the appliance installation diagrams refer to measurements in millimeters and/or inches.

D.1 Introduction

This manual contains information relevant to various appliances. The product images in this guide are only an example.

The drawings and diagrams given in the manual are not in scale. They supplement the written information with an outline,

D.2 Intended use and restrictions

This appliance is designed for cooking food. It is intended for collective use.

Any other use is deemed improper.

**NOTE!**

The manufacturer declines any liability for improper use of the product.

D.3 Testing and inspection

Our appliances have been designed and optimized, with laboratory testing, in order to obtain high performance and efficiency.

Passing of the tests (visual inspection - gas/electrical test - functional test) is guaranteed and certified by the specific enclosures.

D.4 Copyright

This manual is intended solely for consultation by the operator and can only be given to third parties with the permission of

D.5 Keeping the manual

The manual must be carefully kept for the entire life of the appliance, until scrapping. The manual must stay with the appliance in case of transfer, sale, hire, granting of use or leasing.

D.6 Recipients of the manual

This manual is intended for:

- the carrier and handling personnel;
- installation and commissioning personnel;
- the employer of appliance users and the workplace manager;
- operators for normal appliance use;
- specialised personnel - Customer Care service (see service manual).

D.7 Definitions

Listed below are the definitions of the main terms used in the manual. It is advisable to read them carefully before use.

Operator	appliance installation, adjustment, use, maintenance, cleaning, repair and transport personnel.
----------	---

Operator for normal appliance use	an operator who has been informed and trained regarding the tasks and hazards involved in normal appliance use.
-----------------------------------	---

Customer Care service or specialised personnel	an operator instructed/trained by the Manufacturer and who, based on his professional and specific training, experience and knowledge of the accident-prevention regulations, is able to appraise the operations to be carried out on the appliance and recognise and prevent any risks. His professionalism covers the mechanical, electrotechnical and electronics fields etc.
--	--

Danger	source of possible injury or harm to health.
--------	--

Hazardous situation	any situation where an operator is exposed to one or more hazards.
---------------------	--

Risk	a combination of probabilities and risks of injury or harm to health in a hazardous situation.
------	--

Protection devices	safety measures consisting of the use of specific technical means (guards and safety devices) for protecting operators against risks.
--------------------	---

Guard	an element of a appliance used in a specific way to provide protection by means of a physical barrier.
-------	--

Safety device	a device (other than a guard) that eliminates or reduces the risk; it can be used alone or in combination with a guard.
---------------	---

Customer	the person who purchased the appliance and/or who manages and uses it (e. g. company, entrepreneur, firm).
Electrocution	an accidental discharge of electric current on a human body.

D.8 Responsibility

The Manufacturer declines any liability for damage and malfunctioning caused by:

- non-compliance with the instructions contained in this manual;
- repairs not carried out in a workmanlike fashion, and replacements with parts different from those specified in the spare parts catalogue (the fitting and use of non-original spare parts and accessories can negatively affect appliance operation and invalidates the original manufacturer warranty);
- operations carried out by non-specialised personnel;
- unauthorized modifications or operations;
- missing, lack or inadequate maintenance;
- improper appliance use;
- unforeseeable extraordinary events;
- use of the appliance by uninformed and / or untrained personnel;
- non-application of the current provisions in the country of use, concerning safety, hygiene and health in the workplace.

The Manufacturer declines any liability for damage caused by arbitrary modifications and conversions carried out by the user or the Customer.

The employer, workplace manager or service technician are responsible for identifying and choosing adequate and suitable personal protection equipment to be worn by operators, in compliance with regulations in force in the country of use.

The Manufacturer declines any liability for inaccuracies contained in the manual, if due to printing or translation errors.

Any supplements to the installation, use and maintenance manual the Customer receives from the Manufacturer will form an integral part of the manual and therefore must be kept together with it.

D.9 Customer packaging checks

- The forwarder is responsible for the goods during transport and delivery.
- Make a complaint to the forwarder in case of visible or hidden damage.
- Specify any damage or shortages on the dispatch note.
- The driver must sign the dispatch note: the forwarder can reject the claim if the dispatch note is not signed (the forwarder can provide the necessary form).
- For hidden damage or shortages becoming apparent only after unpacking, request the forwarder for inspection of the goods within and no later than 15 days after delivery.

After packaging checks

1. Remove the packaging.
Take care when unpacking and handling of the appliance to not cause any shocks on itself.
2. Keep all the documentation contained in the packaging.

D.10 Storage

The appliance and/or its parts must be stored and protected from damp, in a non-aggressive place, free of vibrations and with room temperatures between 75°C / 167°F and 50°C / 122°F.

The place where the appliance is stored must:

- can take the appliance load,
- have a flat support surface to avoid deforming the appliance or damage to the support feet.

E INSTALLATION AND ASSEMBLY

E.1 Introduction



WARNING

Refer to “*WARNING and Safety Information*”.

To ensure correct operation of the appliance and maintain safe conditions during use, carefully follow the instructions given in this chapter.

Check and, if necessary, level the appliance after positioning. Incorrect levelling can cause appliance malfunctioning.



CAUTION

Before moving the appliance make sure the load bearing capacity of the lifting equipment used is suitable for its weight.



WARNING

The appliance is marked with the induction generator frequency or frequency range in kHz.



WARNING

The appliance generates magnetic fields; frequency range: 10-100 kHz.

E.2 Customer's responsibilities

The tasks and works required of the Customer are:

- check the floor planarity on which the appliance is placed;
- arrange an earthed power socket of suitable capacity for the input specified on the data plate;
- prearrange a high-sensitivity manual-reset magneto-thermal circuit-breaker;
- prearrange a device lockable in the open position for the connection to the power supply.



NOTE!

For information regarding the electrical connection, refer to “A.11 *Electrical connection*”.

E.3 Unpacking instructions

Unpack the appliance carrying out the following operations:

- if present, cut the straps and remove the protective film, taking care not to scratch the surface if scissors or blades are used;
- if present, remove the cardboard top, the polystyrene corners and the vertical protection pieces;
- for appliances with stainless steel surfaces, remove the protective film very slowly without tearing it, to avoid leaving glue stuck to the surface;
- should this happen, remove the traces of glue with a non-corrosive solvent, rinsing it off and drying thoroughly;
- it is advisable to go over all the stainless steel surfaces with a rag soaked in paraffin oil in order to create a protective film.

E.4 Disposal of packing

The packing must be disposed of in compliance with the current regulations in the country where the appliance is used. All the packing materials are environmentally friendly.

They can be safely kept, recycled, or burned in an appropriate waste incineration plant. Recyclable plastic parts are marked as follows:



PE

Polyethylene

- Outer wrapping
- Instructions bag



PP

Polypropylene

- Straps



PS

Polystyrene foam

- Corner protectors

The parts in wood and cardboard can be disposed of, respecting the current regulations in the country where the appliance is used.

E.5 Joining Appliances

1. Undo the 4 fixing screws;
2. Remove the control panels of the appliances (Fig. 1A);
3. Remove the fixing screw nearest the control panel, from each side to be joined (Fig. 1B);
4. Bring the appliances together;
5. Turn the feet to level them until the tops match;
6. Turn one of the two plates inside the appliances 180°C (Fig. 1C);

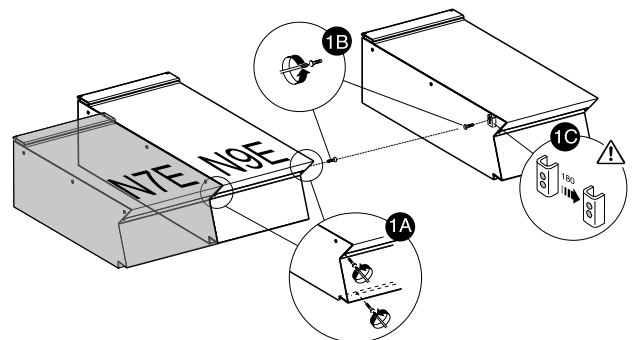

7. From inside the control panel of the same appliance, join them at the front side, screwing one M5x40 Hex Head screw (supplied) on the opposite insert (Fig. 1E);
8. From the rear of the appliances, insert the coupling plate (provided) in the side slots on the back panels;
9. Secure the plate with two flat head M5 screws provided (Fig. 1F).

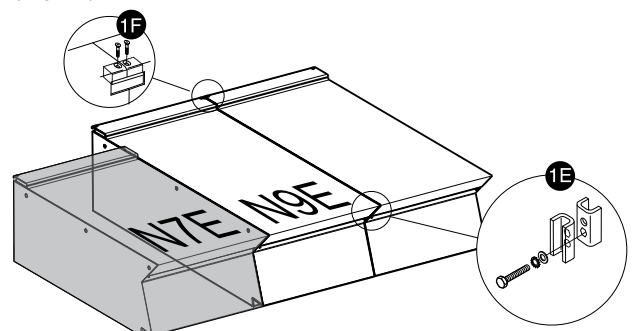

E.5.1 Installation On Bridge or Cantilever Frame (depending on the appliance and/or model)

- Carefully follow the instructions enclosed with the corresponding accessory.
- Follow the instructions supplied with the optional product chosen.

E.5.2 Sealing Gaps Between Appliances

Follow the instructions supplied with the optional sealing paste pack.

E.6 Installation limits

- In case of installation on a counter position a baffle ("A") to separate the cooling air inflow (IN) and outflow (OUT). The baffle must close the space between the bottom and the counter.

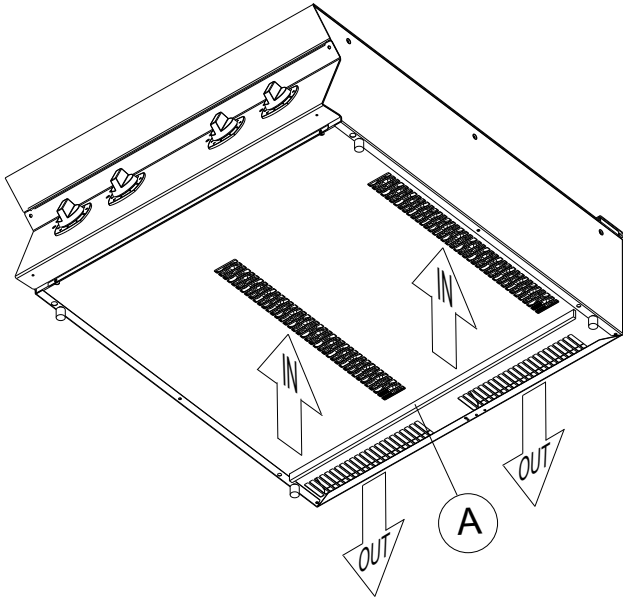

IMPORTANT

The machine is not suitable for installation outdoors and/or in places exposed to atmospheric agents (rain, direct sunlight, etc.) at altitudes exceeding 2000 m above sea level.

E.7 Electrical connection

E.7.1 To access the terminal block

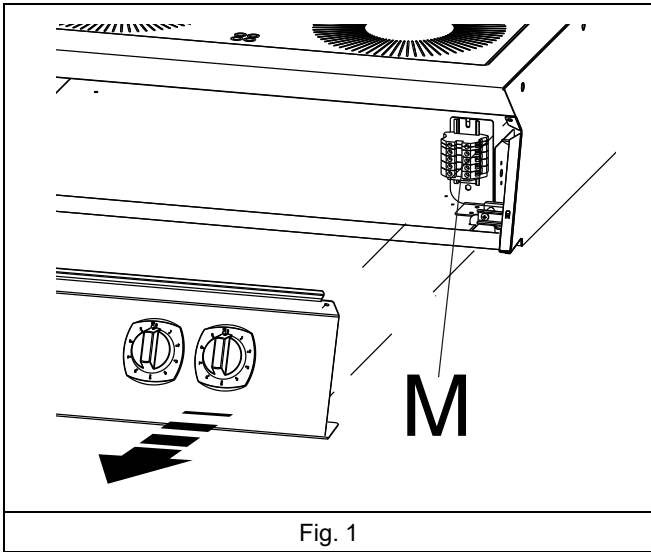

Fig. 1

See fig. 1.

1. Remove the appliance control panel by undoing the fixing screws.
2. Connect the power cable to the terminal block "M" according to the wiring diagram provided with the appliance.
3. Secure the power cable with the cable clamp.
4. After making the connection, with the appliance working check that the power supply does not fluctuate by $\pm 10\%$ the rated voltage.
5. Installation requires the inclusion of a device lockable in the "Open" position during maintenance.

E.8 Power cable

Unless otherwise specified, our appliances are not equipped with a power cable.

The installer must use a flexible cable having characteristics not lower than the H07RN-F rubber insulated type.

Protect the section of cable outside the appliance with a metal or rigid plastic tube.



WARNING

If the power cable is damaged, it must be replaced by the after-sales service or in any case by qualified personnel, in order prevent any risk



WARNING

The manufacturer declines any liability for damage or injury resulting from breach of the above rules or non-compliance with the electric safety regulation in force in the country where the machine is used

E.9 Equipotential node and Earth connection

Connect the appliance to an earth; it must be included in an equipotential node by means of the screw located under the frame.

The screw is marked with the symbol ∇ .

E.10 Circuit breaker

Verify that a safety circuit breaker is installed between the power cable of the appliance and the mains electric line.

The contact opening max. distance and leakage current must comply with the local safety regulations.

F NORMAL APPLIANCE USE



WARNING

Refer to "*WARNING and Safety Information*".

F.1 Characteristics of personnel enabled to operate on the appliance

The Customer must make sure the personnel for normal appliance use are adequately trained and skilled in their duties. The operator must:

- read and understand the manual;

- receive adequate training and instruction for their duties in order to operate safely;
- receive specific training for correct appliance use.



IMPORTANT

The Customer must make sure his personnel have understood the instructions received and in particular those regarding work hygiene and safety in use of the appliance.

F.2 Basic requirements for appliance use

- Knowledge of the technology and specific experience in operating the appliance.
- Adequate general basic education and technical knowledge for reading and understanding the contents of the manual,

including correct interpretation of the drawings, signs and pictograms.

- Sufficient technical knowledge for safely performing his duties as specified in the manual.
- Knowledge of the regulations on work hygiene and safety.

G INSTRUCTION FOR THE USER

G.1 Choice of pots

The induction cooking system works with cookware whose bottom material reacts to the variable magnetic field produced by the components of the equipment.

The use of cookware with different characteristics therefore produces different effects.

It is therefore possible that the performances obtained will change according to the type of cookware used.

The manufacturer offers optional accessories (not included) that guarantee the highest performance.

The induction cooking system is equipped with a pot recognition system.

If the pot is removed from a turned on cooking area, that area switches to stand by automatically.

When the pot is put back on the zone, the zone comes on again.

- It is advisable to use pots specially designed for induction, and in particular multilayer-type pots.
- Use pots with bottom in iron, iron plate, enamelled iron, cast iron, special multilayer metals.
- This heating system does not work with unsuitable materials; these are: nickel-chromium s/steel, aluminium, copper, brass, glass, porcelain.
- Pots of diameter less than approx. **12 cm [4,72"]** are not recognized by the system; heating remains in stand-by.
- It is also advisable to use pots with maximum diameter **28 cm [11,02"]** in order to obtain maximum heating efficiency.
- Do not use empty pots or pans on the appliance as they can quickly reach very high temperatures.



CAUTION

To avoid compromising inductor functionality, never use pots with bottoms that are not perfectly flat: the temperature may not be measured correctly, damaging the appliance.

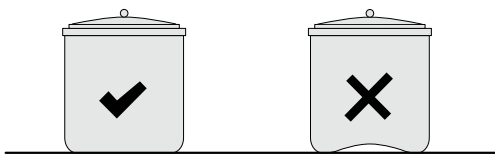

To avoid compromising inductor functionality of the Wok cooktop (if present), never use pots with bottoms flat: the temperature may not be measured correctly, damaging the appliance.

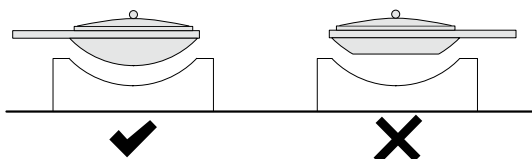

NOTE!

Use pots suggested by in order to obtain max performances of your appliance. For further details please contact

G.2 Introduction

The 1/2 module Wok cooktop has one 5 kW (N7E/N9E) heating zone.

The 1/2 module cooktops have two 3.5 kW (N7E)/5 kW. (N9E) heating zones. The 1 module cooktops have four 3.5 kW (N7E)/ 5 kW (N9E) heating zones.

All the heating zones are independent and can be adjusted separately.



NOTE!

The induction cooking plate (in glass-ceramic) is ready to use; a pre-heat phase is not necessary.

G.2.1 Switching off

- Turn the control knobs "M" to "0".

G.3 Cooking advice

- Never allow two or more pots to touch on the top when switched on.
- Induction has a very low inertia in transferring electric energy from the source to the food: if the energy value is changed the reaction on the food occurs immediately.
- Heating is very rapid: at max. power, bottoms of empty pots and pans reach approximately 200°C [392°F].
- Shifting the pot on the glass-ceramic plate causes uneven conduction of heat on the bottom and therefore food sticking to a part of it: the pot must always remain in the middle of the cooking zone.
- When heating oil or fat, watch the pot constantly because these substances can quickly overheat and burn.
- Optimum even heating is achieved with pots properly centred on the circular serigraphy.
- Never place more than one pot on the same circular area.

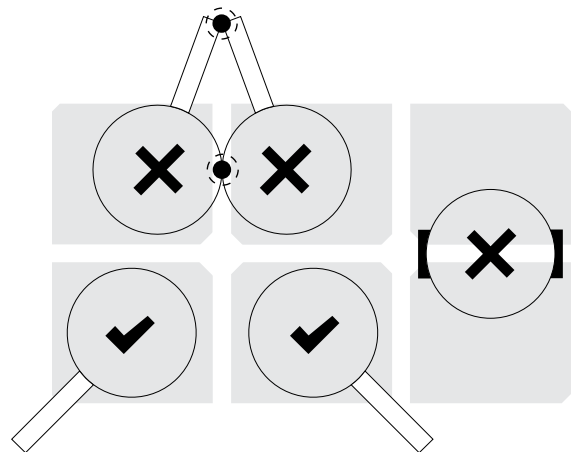

G.4 Induction appliances

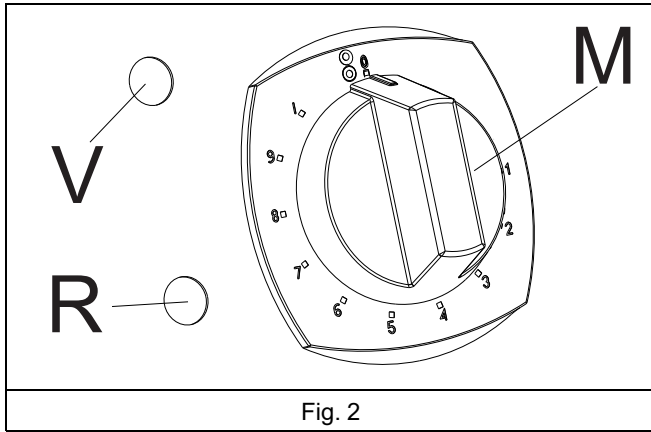

Fig. 2

The control knob "M" of each heating zone has the following positions:

- 0 "Off"
- 1...4 "Minimum power with energy positions range between 1 and 4"

- 5...8 "Medium power with energy positions range between 5 and 8"
- 9 "Maximum power"

The green indicator "V" signals that the power is on.

The red indicator "R" signals a serious problem in the inductor.

Switching on

See fig. 2.

1. Turn on the main switch located ahead of the appliance;
2. turn knob "M" to the desired power, to turn on the relevant heating zone;
3. when the switch is turned on and a suitable pot is positioned on the appliance, the green indicator "V" lights up.
4. if there are no pots or an unsuitable pot on the appliance, the green indicator "V" flashes at 2-second intervals.

Switching off

See fig. 2.

- Turn the control knobs "M" to "0".

H APPLIANCE CLEANING AND MAINTENANCE



WARNING

Refer to "*WARNING and Safety Information*".

H.1 Care information

Care operations have to be carried out by the owner and/or user of the appliance.



IMPORTANT

Problems resulting from poor or lack of care as hereinafter described will not be covered by the warranty.

H.2 Cleaning introduction

In order to reduce the environmental impact of pollutants it is advisable to clean the appliance (externally and, where necessary, internally) with products that are more than 90% biodegradable.

Use lukewarm water, a neutral detergent/cleaner if necessary, and a soft brush or sponge. If another type of detergent is used, carefully follow the producer's instructions and observe the safety rules given in the information sheets provided with the product or substance.

Rinse and dry thoroughly.

H.3 Maintenance intervals

It is advisable to carry out the checks with the frequency given in the following table:

Maintenance, inspections, checks and cleaning	Frequency	Responsibility
Ordinary cleaning • general cleaning of appliance and surrounding area	• Daily	• Operator
Mechanical protection devices • check their condition and for any deformation, loosening or removed parts	• Every 6 months	• Service
Control • check the mechanical parts, for cracks or deformations, tightening of screws: check the readability and condition of words, stickers and symbols and restore if necessary	• Yearly	• Service



CAUTION

- Do not use solvent-based detergents (e. g. trichloro-ethylene) or abrasive powders for cleaning.
- Do not use steel brushes, steel wool, copper cloths, sand-based or similar products for cleaning.

Accessories such as baskets and containers, if present, must be cleaned outside of the appliance.



WARNING

When using chemicals, comply with the safety notes and dosage recommendations printed on the packaging. Refer to the chapter *A.2 Personal protection equipment* for handling chemical products.

Maintenance, inspections, checks and cleaning	Frequency	Responsibility
Appliance structure <ul style="list-style-type: none"> tightening of main bolts (screws, fixing systems, etc.) of appliance 	<ul style="list-style-type: none"> Yearly 	<ul style="list-style-type: none"> Service
Safety signs <ul style="list-style-type: none"> check the readability and condition of safety signs 	<ul style="list-style-type: none"> Yearly 	<ul style="list-style-type: none"> Service
Electrical control panel <ul style="list-style-type: none"> check the electrical components installed inside the electrical control panel. Check the wiring between the electrical panel and appliance parts 	<ul style="list-style-type: none"> Yearly 	<ul style="list-style-type: none"> Service
Electrical connection cable <ul style="list-style-type: none"> check the connection cable (replace if necessary) 	<ul style="list-style-type: none"> Yearly 	<ul style="list-style-type: none"> Service
General appliance overhaul <ul style="list-style-type: none"> check all components, electrical equipment, corrosion, pipes... 	Every 10 years ¹	<ul style="list-style-type: none"> Service

1. The appliance is designed and built for a duration of about 10 years. After this period of time (from commissioning) the appliance must undergo a general inspection and overhaul.

H.4 Periods of non-use

If the appliance is not going to be used for some time, take the following precautions:

- close the water supply tap(s), if present;
- disconnect the power supply or remove the plug from the power socket, if present;
- clean the cabinet, going over all the stainless steel surfaces vigorously with a rag moistened with paraffin oil to create a protective film;
- leave the door or drawers, if present, open so that air can circulate inside, preventing the formation of unpleasant odours;
- for the electric heated models: switch on the appliance at the minimum rate of heat for at least 45 minutes; this will allow moisture/humidity accumulated into the heating elements to evaporate without damaging the elements;
- periodically air the premises.

H.5 External parts

SATIN-FINISH STEEL SURFACES (daily)

- Clean all steel surfaces: dirt is easily removed when it has just formed.
- Remove grime, fat and other cooking residuals from steel surfaces when cool using soapy water, with or without detergent, and a cloth or sponge.
Dry the surfaces thoroughly after cleaning.
- In case of encrusted grime, fat or food residuals, go over with a cloth or sponge, wipe in the direction of the satin finish and rinse often:
Rubbing in a circular motion combined with the particles of dirt on the cloth/sponge could spoil the steel's satin finish.
- Metal objects can spoil or damage the steel: damaged surfaces become dirty more easily and are more subject to corrosion.
- Restore the satin finish if necessary.

SURFACES BLACKENED BY HEAT (when necessary)

- Exposure to high temperatures can cause the formation of dark marks.
These do not constitute damage and can be removed by following the instructions given in the previous section.

H.6 Ceramic — glass surfaces

- Clean the glass-ceramic top using a paper serviette soaked in a specific detergent for glass; rinse the top, then dry with a clean and dry cloth.

- Do not clean the top when hot.

H.7 Induction surfaces

- It is forbidden to use aluminium foil in proximity of the induction zones: relevant damages shall not be covered by the manufacturer warranty.
- If noticing aluminium foils (even in small pieces), immediately remove to prevent damaging the induction device.



CAUTION

Make sure no water comes into contact with electrical components: water penetration can cause short circuiting and dissipation, tripping the appliance's protection devices.

H.8 Induction full surface air filters

- To avoid breakage and damaging the appliance, check and clean the filter at least once a month; this operation must be carried out by an authorized technician.
 - For cleaning:
 - remove the filter from its seat;
 - bang it hard to clean off the dust;
 - If the filter is dirty with grease, wash it with degreasing soap, then rinse and dry;
 - at the end of the operation, refit the filter in its seat.
- Every three months it is advisable to replace the filter if it has deteriorated.

H.9 Internal parts (every 6 months)



IMPORTANT

Operations to be carried out only by specialised personnel.

- Check the condition of the internal parts.
- Remove any deposits of dirt inside the appliance.
- Check and clean the discharge system.



IMPORTANT

In particular conditions (e.g. intensive use of the appliance, salty environment, etc.) the above cleaning should be more frequent.

H.10 Warnings

Red light, if present, and green light flashing between two longer lighting phases requires an initial action by the user and,

if necessary, a more thorough check by Customer Care Service, (see the table given below).

Each cooking zone has an internal temperature control device that activates before any overheating, reducing the cooking zone power.

- If overheating persists, the cooking zone is temporarily turned off.

- Cooling is quicker if the pot is taken off the glass-ceramic plate.
- It is advisable to turn the zone off with the control knob and wait a while.

When cooled, the cooking zone can be switched on again by turning the control knob from "0" to the desired setting.

H.11 Warnings codes

Nr. lamp green led	Warning	Cause	Corrective Action (User)	Corrective Action (After-Sales Service)
1	Cooking zone overtemperature	The zone temperature is too high	Switch of the power zone and restart after zone cooling down	—
		Material of pot unsuitable	Use a pot made from appropriate material	—
2	None	—	—	—
3	Main board IGBT temperature sensor	Dirty air filters	Disconnect the appliance from the mains and call the after-sales service	Clean the air filters
		Cooling duct obstructed		Make sure the cooling air inlet and outlet are not blocked
		Ingestion of hot air from the cooling inlets		Check the cooling air path
		Cooling fan blocked or faulty		Clean the cooling fan if problem persists replace the induction generator
		Temperature sensor of power terminals faulty		Replace the induction generator
4	Potentiometer error	Disconnection between the generator and controls	Disconnect the appliance from the mains and call the after-sales service	Check the internal connections
		Potentiometer faulty		Replace potentiometer
5	Main board failure on +15V power supply output	Induction generator failure	Disconnect the appliance from the mains and call the after-sales service	Replace the induction generator
6	Cooling system failure	Cooling fan blocked	Disconnect the appliance from the mains and call the after-sales service	Clean or replace the cooling fan
7	Cooking zone temperature sensor	Inductor temperature sensor disconnected or interrupted	Disconnect the appliance from the mains and call the after-sales service	Check the inductor temperature sensor if it works replace induction generator
8	None	—	—	—
9	None	—	—	—
10	Main board power circuit failure	Phase relay faulty	Disconnect the appliance from the mains and call the after-sales service	Replace the induction generator
11	Zone temperature sensor out of range	Sensor is shorted or the conditioning circuit is not working properly	Disconnect the appliance from the mains and call the after-sales service	Check the inductor temperature sensor if it works replace induction generator
12	None	—	—	—
13	Main board mains voltage	Generator mains voltage to low	Disconnect the appliance from the mains and call the after-sales service	Check the main power supply
14	None	—	—	—
15	Main board microcontroller error	Induction generator failure	Disconnect the appliance from the mains and call the after-sales service	Replace the induction generator

I TROUBLESHOOTING

I.1 Introduction

Certain faults may occur during normal use of the appliance. In some cases, faults can be eliminated easily and quickly by following the indication below.

If the fault persists, contact the Customer Care Service:

1. Disconnect the appliance from the main power supply;
2. Switch off the safety circuit breaker ahead of the appliance;

3. Close the gas and water tap(s), if they are present;
4. Remember to specify:
 - the type of fault
 - the appliance PNC (product number code)
 - the Ser. No. (appliance serial number).



IMPORTANT

The appliance PNC and serial number are essential for identifying the type of appliance and date of manufacture.

I.2 Inefficiencies detected during cooking

INEFFICIENCY	CAUSE	CORRECTIVE ACTION
Insufficient heating of cooking zone	Material of pot unsuitable	Use a pot made from appropriate material
	Over temperature	Switch off the appliance, cool down and check if the filters are dirty
No heating of cooking zone	Pot bottom less than 12 cm wide	Use a pot of suitable size
	Over temperature	Switch off the appliance, cool down and check if the filters are dirty
	Material of pot unsuitable	Use a pot made from appropriate material

J APPLIANCE DISPOSAL



WARNING

Refer to “*WARNING and Safety Information*”.

J.1 Procedure regarding appliance disposal

At the end of the product's life-cycle, make sure it is not dispersed in the environment.

Different regulations are in force in the various countries, therefore comply with the provisions of the laws and competent bodies in the country where appliance disposal takes place.

The appliance's parts must be disposed of in a differentiated way, according to their different characteristics (e. g. metals, oils, greases, plastic, rubber, etc.).

Before disposing of the appliance, make sure to carefully check its physical condition, and in particular any parts of the structure that can give or break during dismantling.

Depending on the model, the doors must be removed before dismantling the appliance.

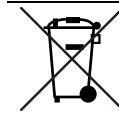

The symbol on the product indicates that this product should not be treated as domestic waste, but must be correctly disposed of in order to prevent any negative consequences for the environment and human health. For further information on the recycling of this product, contact the local dealer or agent, the Customer Care service or the local body responsible for waste disposal.



NOTE!

When dismantling the appliance, any marking, this manual and other documents concerning the appliance must be destroyed.