

**MOD :DLW40-TS/N**

**Production code : S40DDIELS1AIA03**

*SCHEDA TECNICA LAVATRICI / TECHNICAL DATA SHEET*



**DLW40-TS/N**



SCHEDA TECNICA LAVATRICI LM40/55/70/85 - LM40/55/70/85 WASHING MACHINE DATA SHEET

CARATTERISTICHE GENERALI GENERAL TECHNICAL DATA	DLW	DLW40-TS/N	DLW55-TS/N	---	---
CAPACITA' CAPACITY	Kg (lb)	40 (88)	55 (121)	70 (154)	85 (187)
DIAMETRO CESTO DRUM DIAMETER	Ø (mm) Ø (inches)	880 (34.6)	1080 (42.5)	1200 (47)	1200 (47)
PROFONDITA' CESTO DRUM DEPTH	(mm) (inches)	650 (25.6)	603 (23.4)	618 (24.3)	750 (29.5)
DIAMETRO DI CARICO LOAD DIAMETER	Ø (mm) Ø (inches)	530 (20.8)	530 (20.8)	530 (20.8)	530 (20.8)
VELOCITA' DI CENTRIFUGA SPIN SPEED	rpm	802	802	723	723
FATTORE G G FACTOR	-	351	351	351	351
INTENSITA' SONORA AEREA AIR SOUND INTENSITY	dB(A)	70	70	72	72
PERDITE AL MANTELLO HEATING LEAK	%	5	5	5	5
SFIATO (pos.5) VENT (pos.5)	Ø (mm) Ø (inches)	80 (3)	80 (3)	80 (3)	80 (3)
PESO NETTO NET WEIGHT	(Kg) (lb)	1451.9 (3201)	1620.9 (3573)	1810.9 (3992.3)	1851.8 (4082.5)
CARICO DINAMICO (FREQUENZA) DYNAMIC LOAD (FREQUENCY)	N (Hz)	17228 (13.4)	17228 (13.4)	22393 (12Hz)	17226 (12Hz)

IMBALLO STANDARD STANDARD PACKING	DLW	DLW40-TS/N	DLW55-TS/N	---	---
LARGHEZZA WIDTH	(mm) (inches)	1540 (60.6)	1540 (60.6)	1700 (66.9)	1750 (68.8)
PROFONDITA' DEPTH	(mm) (inches)	1700 (66.9)	1700 (66.9)	1540 (61.4)	1700 (66.9)
ALTEZZA HEIGHT	(mm) (inches)	1910 (75.1)	1910 (75.1)	2200 (86.6)	2200 (86.6)
VOLUME VOLUME	m <sup>3</sup> (ft <sup>3</sup> )	5 (176.5)	5 (176.5)	5.8 (205)	6.5 (229.5)
PESO LORDO GROSS WEIGHT	(Kg) (lb)	1510 (3229)	1680 (3703)	1870 (4122.6)	1912 (4215.2)

PIANO DI CARICO CONTAINER CONTAINER LOADING PLAN	DLW	DLW40-TS/N	DLW55-TS/N	---	---
CONTAINER 20"	PZ.	3	3	3	3
CONTAINER 40"	PZ.	7	7	7	7

CONNESSIONI SUPPLY	DLW	DLW40-TS/N	DLW55-TS/N	---	---
CONNESSIONE ACQUA FREDDA (pos.1) COLD WATER INLET (pos.1)	Ø	1 ½"	1 ½"	1 ½"	1 ½"
CONNESSIONE ACQUA CALDA (pos.2) HOT WATER INLET (pos.2)	Ø	1 ½"	1 ½"	1 ½"	1 ½"
CONNESSIONI ACQUE WATER SUPPLY	bar	0,5÷10	0,5÷10	0,5÷10	0,5÷10
CONSUMO ACQUA FREDDA* COLD WATER CONSUMPTION*	(l) (ft <sup>3</sup> )	440 (15.5)	605 (21.3)	770 (27.2)	935 (33)
CONSUMO ACQUA CALDA* HOT WATER CONSUMPTION*	(l) (ft <sup>3</sup> )	80 (2.8)	110 (3.8)	140 (4.9)	170 (6)
CONSUMO ACQUA* WATER CONSUMPTION*	(l) (ft <sup>3</sup> )	520 (18.3)	715 (25.2)	910 (32.1)	1105 (39)
SCARICO (pos.4) DRAIN (pos.4)	Ø (mm) Ø (inches)	80 (3)	80 (3)	80 (3)	80 (3)
PORTATA SCARICO DRAIN FLOW	lt/min (ft <sup>3</sup> /min)	200 (7)	200 (7)	200 (7)	200 (7)

RISCALDAMENTO ELETTRICO ELECTRIC HEATING	DLW	DLW40-TS/N	DLW55-TS/N	---	---
POTENZA ELETTRICA ELECTRIC POWER	kW	29	36	38	40
POTENZA DI RISCALDAMENTO HEATING POWER	kW	6x4=24kW	6x5=30kW	6x5=30kW	6x5=30kW
CORRENTE CURRENT 3ph400V-480V(+N)/3ph230V	A	49/85	60/103	61/106	65/106
CONSUMO ELETTRICO* ELECTRIC CONSUMPTION*	kWh	4	6,5	8	10

RISCALDAMENTO VAPORE STEAM HEATING	DLW	DLW40-TS/N	DLW55-TS/N	---	---
POTENZA ELETTRICA ELECTRIC POWER	kW	4	9	9	9
CORRENTE CURRENT 3ph400V-480V(+N)/3ph230V	A	12/20	16/28	16/28	16/28
CONSUMO ELETTRICO* ELECTRIC CONSUMPTION*	kWh	2,7	3,3	4	5
CONNESSIONE VAPORE STEAM CONNECTION	Ø	¾"	¾"	¾"	¾"
MASSIMA PRESSIONE VAPORE MAX STEAM PRESSURE	Bar	9	9	9	9
CONSUMO VAPORE* STEAM CONSUMPTION*	Kg (lb)	1 (2.2)	1,4 (3)	1.8 (3.9)	2.2 (4.8)

SOLO ACQUA CALDA SERVITA HOT WATER ONLY	DLW	DLW40-TS/N	DLW55-TS/N	---	---
POTENZA ELETTRICA ELECTRIC POWER	kW	4	9	9	9
CORRENTE CURRENT 3ph400V-480V(+N)/3ph230V	A	12/20	16/28	16/28	16/28
CONSUMO ELETTRICO* ELECTRIC CONSUMPTION*	kWh	2,7	3,3	4	5

\* Lavaggio "COTONE" 60°C, EN60456, tab. A2: lavaggio 60°C (15') e 4 risciacqui a freddo (3'+3'+2'+2'), ritmo motore 12"/3"/12"; centrifughe intermedie e 5' di centrifuga finale: cotone 180gr/m<sup>2</sup>. Acqua fredda a 15°C; acqua calda servita a 60°C

\* Cycle "COTTON" 60°C, EN60456, tab. A2: wash 60°C (15') and 4 cold rinses (3'+3'+2'+2'), motor rhythm 12"/3"/12"; middle spins and 5' final spin: cotton 180gr/m<sup>2</sup>. Cold water 15°C, hot water supply 60°C.

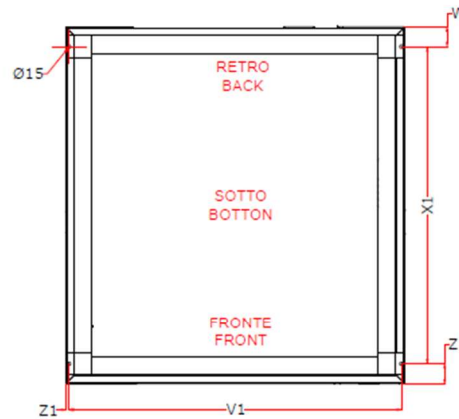
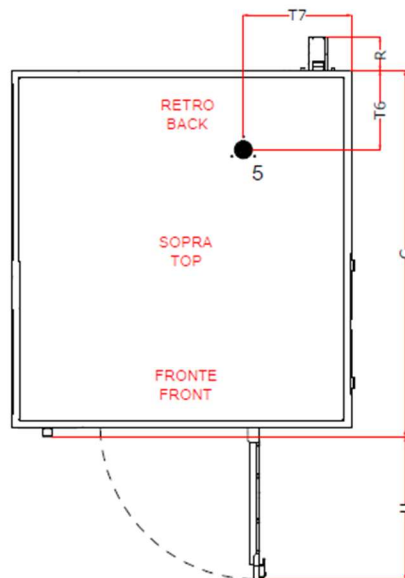
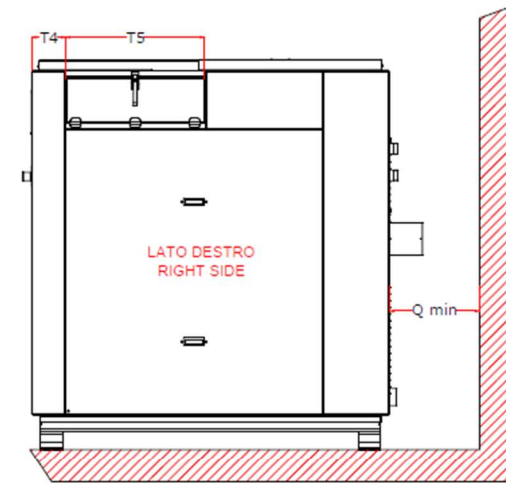
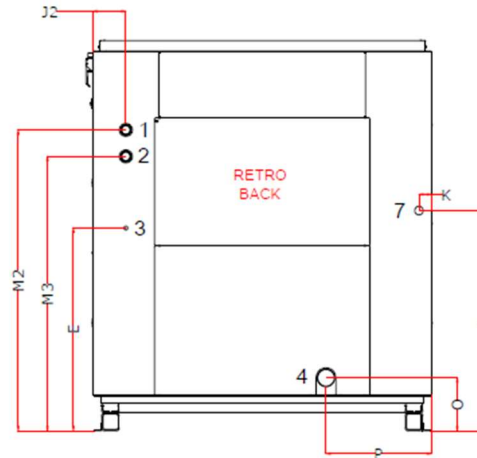
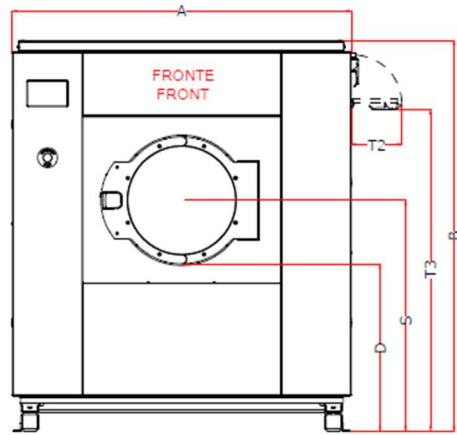

ATTENZIONE! L'APPLICAZIONE DI ALCUNI  
 OPTIONAL RICHIEDE LA CONSULTAZIONE DI  
 SCHEDE TECNICHE DEDICATE:

- MACCHINE VERSIONE  
 TILTING
- MACCHINE CON SISTEMA DI  
 PESATURA

ATTENTION! THE APPLICATION OF SOME  
 OPTIONALS REQUIRES THE CONSULTATION  
 OF DEDICATED TECHNICAL SHEETS:

- TILTING VERSION MACHINES
- MACHINES WITH WEIGHING  
 SYSTEM

mm (inches)	DLW40-TS/N	DLW55-TS/N	---	---
A (larghezza/width)	1540 (60.6)	1540 (60.6)	1700 (66.9)	1700 (66.9)
B	1770 (69.7)	1770 (69.7)	2020 (79.5)	2020 (79.5)
C (profondità/depth)	1452 (57.2)	1667 (65.6)	1479 (58.2)	1611 (63.4)
D	757 (29.8)	757 (29.8)	890 (35)	890 (35)
E	920 (36.2)	920 (36.2)	975 (38.4)	975 (38.4)
K	58 (2.3)	58 (2.3)	57 (2.2)	57 (2.2)
L	1000 (39.4)	1000 (39.4)	1249 (49.1)	1249 (49.1)
O	240 (9.4)	240 (9.4)	240 (9.4)	240 (9.4)
P	480 (18.9)	480 (18.9)	580 (22.8)	580 (22.8)
Q <sub>min</sub>	600 (23.6)	600 (23.6)	600 (23.6)	600 (23.6)
S	1046 (41.2)	1046 (41.2)	1179 (46.4)	1179 (46.4)
T2	230 (9)	230 (9)	233 (9.2)	233 (9.2)
T3	1458 (57.4)	1458 (57.4)	1710 (67.3)	1710 (67.3)
T4	155 (6)	155 (6)	150 (5.9)	150 (5.9)
U	623 (24.5)	623 (24.5)	623 (24.5)	623 (24.5)
W	90 (3.5)	90 (3.5)	90 (3.5)	90 (3.5)
X1	1230 (48.4)	1445 (56.9)	1255 (49.4)	1387 (54.6)
Z1	15 (0.6)	15 (0.6)	15 (0.6)	15 (0.6)
Z2	90 (3.5)	90 (3.5)	90 (3.5)	90 (3.5)

Pos. 1	ACQUA FREDDA / COLD WATER
Pos. 2	ACQUA CALDA / HOT WATER
Pos. 3	VAPORE DIRETTO / DIRECT STEAM (solo macchine vapore / only steam heated machines)
Pos. 4	SCARICO ACQUA / DRAIN VALVE
Pos. 5	SFIATO / VENT
Pos. 7	ALIMENTAZIONE ELETTRICA / ELECTRICAL POWER SUPPLY
Pos. 9	CARICO DETERSIVI / DETERGENT LOAD