



MOD : DS12/A7-P9B

Production code : CV120PSVGD110BH_1

10/2025

Rev.	Modification	Date
00	Prima Emissione	06/09/2022

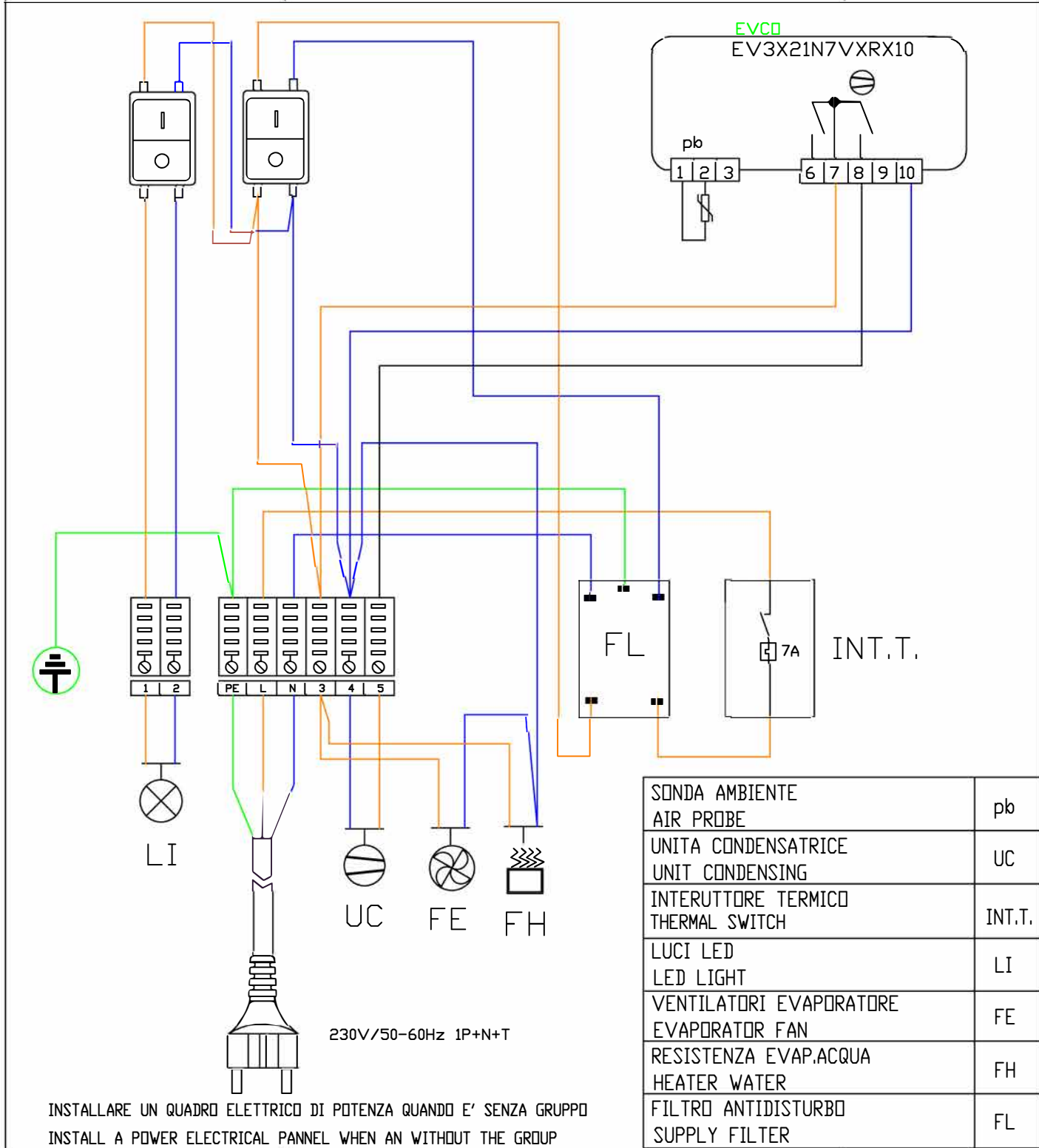

INSTALLARE UN QUADRO ELETTRICO DI POTENZA QUANDO E' SENZA GRUPPO
 INSTALL A POWER ELECTRICAL PANNEL WHEN AN WITHOUT THE GROUP

Approved By:	Eletrical Schematic	Date
	Model	DALLAS LINE
	Details:	DS10/B5-(A7)P9B - DS12/B5-(A7)P9B - DS15/B5-(A7)P9B
		06/09/2022