



MOD : DS10/B5-P9B

Production code : CV100PSVND97BH_1

10/2025

Rev.	Modification	Date
00	Prima Emissione	06/09/2022

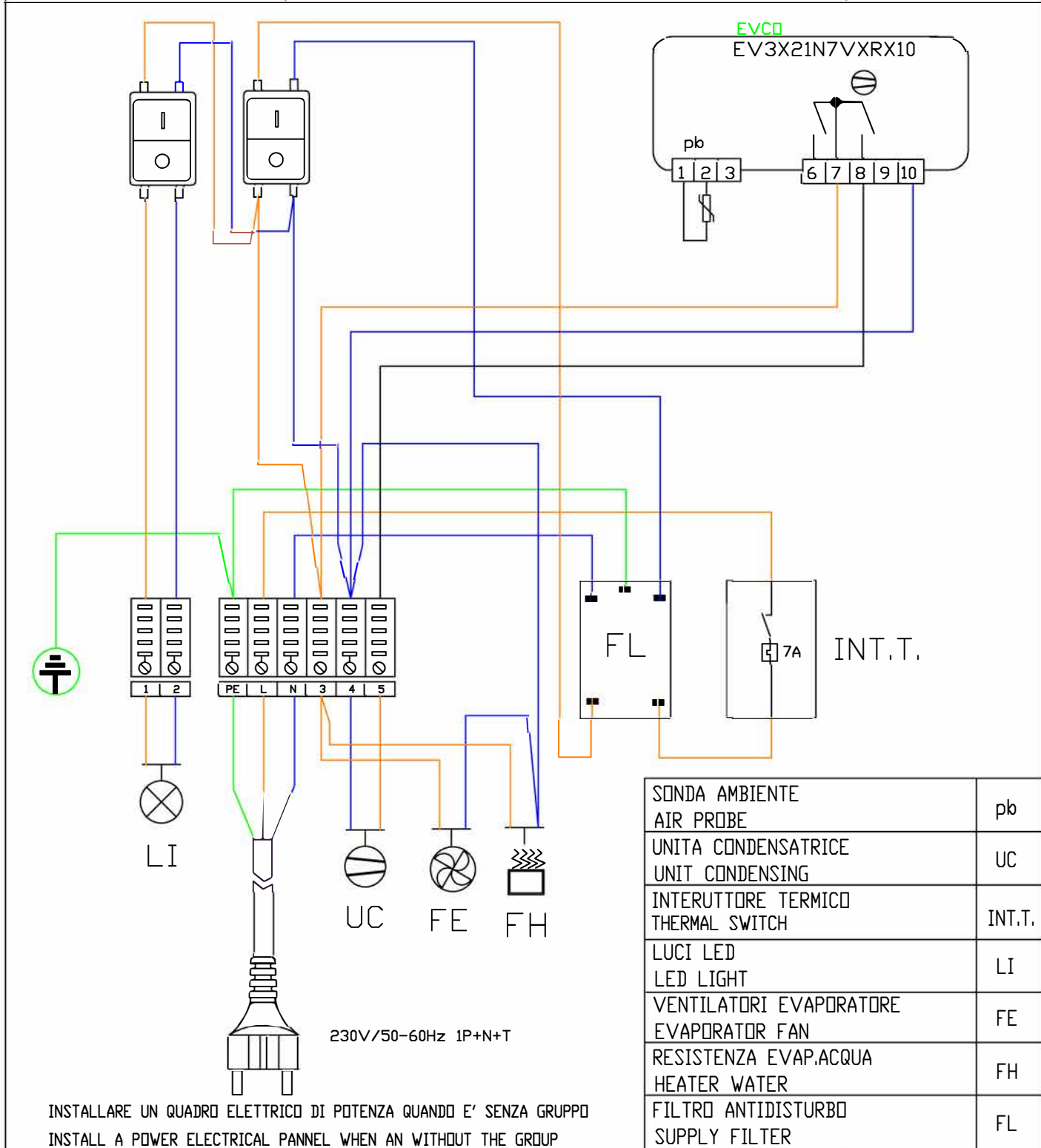

Approved By:	Eletrical Schematic	Date
	Model	DALLAS LINE
	Details:	DS10/B5-(A7)P9B - DS12/B5-(A7)P9B - DS15/B5-(A7)P9B
		06/09/2022

IL FRIGORIFERO DEVE ESSERE ALLACCIATO AD UN INTERRUOTTORE DIFFERENZIALE ONNIPOLARE ADEGUATO ALLA POTENZA CON id=0,03A E COLLEGATO ALL'IMPIANTO DI MESSA A TERRA