

MOD : WR-TGRP-12

Production code : FTG127_

**Meat grinder and grater / Picadora de carne y rallador /
Hachoir à viande et râpe / Fleischwolf und Reibe /
Tritacarne e grattugia**

*TECHNICAL DATA SHEET / FICHA TÉCNICA / FICHE TECHNIQUE /
TECHNISCHES DATENBLATT / SCHEDA TECNICA*

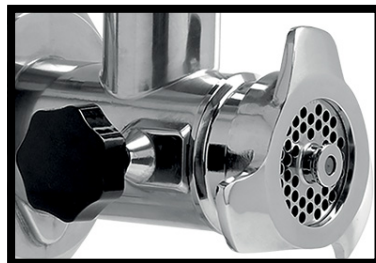

TECHNICAL AND MANUFACTURING DATA

TECHNICAL DATA	MODEL	
	WR-TGRP-12	WR-TGRP-22
Motor power (kW) / (Hp)	0.75 / 1	1.1/ 1,5
Grinding mouth internal size (mm)	70	82
Grater mouth internal size (mm)	140x75	140x75
Mincer timetable production (kg/h)	150 / 200	300
Grater timetable production (kg/h)	50	50
Mass (kg)	23	27
Maximum sizes: A x B x C (mm)	550 x 220 x 460	610 x 220 x 460

GROUP	MODEL	
	WR-TGRP-12	WR-TGRP-22
Basic machine body	●	●
Hulled machine body (I)		
Grinding group Enterprise	●	●
Grinding group Enterprise (Uniko)		
Optional tomato masher	●	●
Optional puree masher	●	●
Stamped grater roll (Standard)	●	●
Milled grater roll (Optional)	●	●

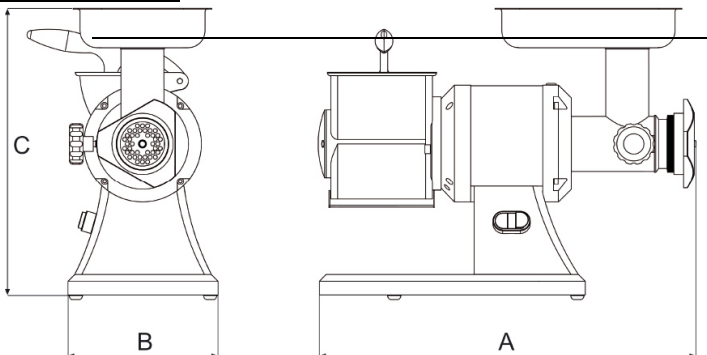

Continue acoustic power level considered equal to A	Minor of 70dBA
Current nature – Frequency	Machine plate
Full charge current	Machine plate
Use nominal voltage	Machine plate
Auxiliary circuits voltage	AC 24V – DC 24V
Mass and neutral	TT e TN
Protection degree	IP X3
Use place	Inside
Machine positioning	Working ground used in the food field of height included between 900/1100mm from the trampling level of adequate capacity, with a free circulation space of at least 800mm
Environment air max. temperature	+40°C
Requested minimum illumination	500 lux
Product directive conformance	2006/42/CE, Reg.1935/2004 e Reg.2023/2006

DATOS TÉCNICOS Y CONSTRUCTIVOS

DATOS TÉCNICOS	MODELO	
	WR-TGRP-12	WR-TGRP-22
Potencia motor (kW) / (Hp)	0.75 / 1	1.1 / 1,5
Dimensión interior boca molienda (mm)	70	82
Dimensión interna boca rallador (mm)	140x75	140x75
Producción horaria picadora (kg/h)	150 / 200	300
Producción horaria rallador (kg/h)	50	50
Masa (kg)	23	27
Dimensiones estorbo: A x B x C (mm)	550 x 220 x 460	610 x 220 x 460

GRUPO	MODELO	
	WR-TGRP-12	WR-TGRP-22
Cuerpo maquina base	●	●
Cuerpo maquina carenado (I)		
Grupo molienda Enterprise	●	●
Grupo molienda Enterprise (Uniko)		
Optional pasatomate	●	●
Optional pasapuré	●	●
Rodillo rallador punzonado (Standard)	●	●
Rodillo rallador fresado (Optional)	●	●

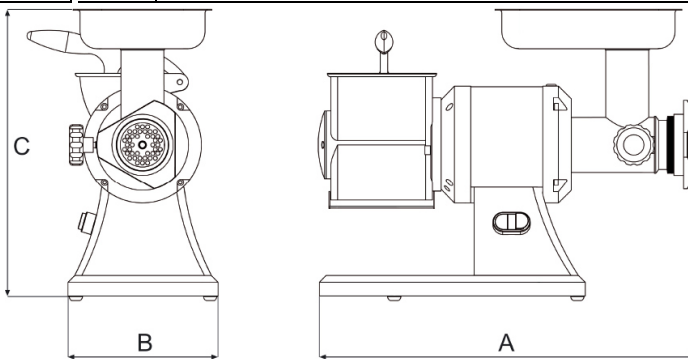

Nivel de potencia acústica continuo equivalente ponderado A	Menor de 70dBA
Natura de la corriente - Frecuencia	Cfr. matricula de la máquina
Corriente a lleno cargo	Cfr. matricula de la máquina
Tensión nominal de empleo	Cfr. matricula de la máquina
Tensión de los circuitos auxiliares	AC 24V – DC 24V
Masa y neutro	TT e TN
Grado de protección	IP X3
Lugar de empleo	Al interior
Posicionamiento de la máquina	Banco de trabajo empleado en el sector alimenticio de altura incluida entre 900/1100mm del plan de pisoteo de adecuado alcance, con un espacio libre de circulación de al menos 800mm
Temperatura aire entorno max	+40°C
Iluminación mínima solicitada	500 lux
Conformidades directivas de producto	2006/42/CE, Reg.1935/2004 e Reg.2023/2006

DONNEES TECHNIQUES ET CONSTRUCTIVES

DONNEES TECHNIQUES	MODELE	
	WR-TGRP-12	WR-TGRP-22
Puissance moteur (kW) / (Hp)	0.75 / 1	1.1/ 1,5
Dimension intérieur bouche broyage (mm)	70	82
Dimension intérieure râpe(mm)	140x75	140x75
Production horaire hache-viande (kg/h)	150 / 200	300
Production horaire râpe (kg/h)	50	50
Masse (kg)	23	27
Dimensions encombrement: A x B x C (mm)	550 x 220 x 460	610 x 220 x 460

GROUPE	MODELE	
	WR-TGRP-12	WR-TGRP-22
Corps machine base	●	●
Corps machine caréné (I)		
Groupe broyage Enterprise	●	●
Groupe broyage Enterprise (Uniko)		
Optional presse-tomates	●	●
Optional presse-purée	●	●
Rouleau râpe poinçonné (Standard)	●	●
Rouleau râpe fraisé (Optional)	●	●

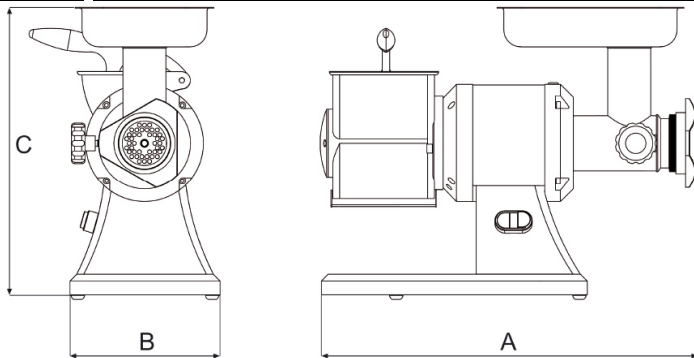

Niveau de puissance acoustique continu équivalent pondéré A	Inférieur à 70dBA
Nature du courant - Fréquence	Cf. Plaque de la machine
Courant à pleine charge	Cf. Plaque de la machine
Tension nominale d'emploi	Cf. Plaque de la machine
Tension des circuits auxiliaires	AC 24V – DC 24V
Masse et conducteur neutre	TT e TN
Degré de protection	IP X3
Lieu d'emploi	A l'intérieur
Positionnement de la machine	Banc de travail employé dans le secteur alimentaire d'hauteur comprise entre 900/1100mm du plan de piétinement de portée adéquate, avec un espace libre de circulation d'au moins 800mm
Température air environnement max	+40°C
Eclairage minimal demandé	500 lux
Conformités directives de produit	2006/42/CE, Reg.1935/2004 e Reg.2023/2006

TECHNISCHE UND BAUTECHNISCHE DATE

TECHNISCHE DATEN	MODELL		EINHEIT	MODELL	
	WR-TGRP-12	WR-TGRP-22		WR-TGRP-12	WR-TGRP-22
Motorleistung (kW) / (Hp)	0.75 / 1	1.1 / 1,5	Losser Gerätekörper	●	●
Innenmaße Zerkleinerungsvorsatz (mm)	70	82	Verkleideter Gerätekörper (I)		
Innenmaße Raspelvorsatz (mm)	140x75	140x75	Zerkleinerungseinheit Enterprise	●	●
Stundenproduktion Fleischwolf (kg/Std.)	150 / 200	300	Zerkleinerungseinheit Enterprise (Uniko)		
Stundenproduktion Käsereiber (kg/Std.)	50	50	Optional Tomatenpürierer	●	●
Masse (kg)	23	27	gestanzte Raspelrolle (Standard)	●	●
Abmessungen: A x B x C (mm)	550 x 220 x 460	610 x 220 x 460	gefräste Raspelrolle (Zusatzzubehör)	●	●

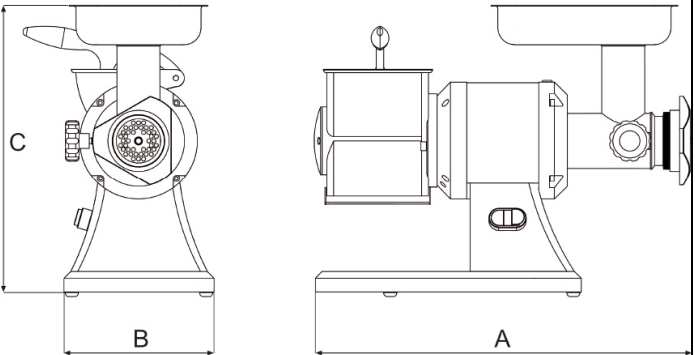

Äquivalenter Dauerschallpegel A	unter 70dBA
Strombeschaffenheit - Frequenz	Siehe Kennschild am Gerät
Nennleistung	Siehe Kennschild am Gerät
Nominale Betriebsspannung	Siehe Kennschild am Gerät
Spannung Hilfskreise	AC 24V – DC 24V
Masse und Neutralleiter	TT und TN
Schutzgrad	IP X3
Anwendungsort	Innenraum
Aufstellung des Geräts	Arbeits Tisch für den Lebensmittelbereich in der Höhe zwischen 900/1100mm , abgemessen vom Fußboden passender Tragfähigkeit, mit einem freien Handlungsraum von mind. 800mm
Max. Lufttemperatur	+40°C
Min. Beleuchtung	500 lux
Konformität Produkt Richtlinien	2006/42/CE, Verordn.1935/2004 e Verordn.2023/2006

DATI TECNICI E COSTRUTTIVI

DATI TECNICI	MODELLO		GRUPPO	MODELLO	
	WR-TGRP-12	WR-TGRP-22		WR-TGRP-12	WR-TGRP-22
Potenza motore (kW) / (Hp)	0.75 / 1	1.1 / 1,5	Corpo macchina base	●	●
Dimensione interna bocca macinazione (mm)	70	82	Corpo macchina carenato (I)		
Dimensione interna bocca grattugia (mm)	140x75	140x75	Gruppo macinazione Enterprise	●	●
Produzione oraria tritacarne (kg/h)	150 / 200	300	Gruppo macinazione Enterprise (Uniko)		
Produzione oraria grattugia (kg/h)	50	50	Optional passapomodoro	●	●
Massa (kg)	23	27	Optional passapuraea	●	●
Dimensioni ingombro: A x B x C (mm)	550 x	610 x	Rullo grattugia punzonato (Standard)	●	●
	220 x	220 x	Rullo grattugia fresato (Optional)	●	●
	460	460			

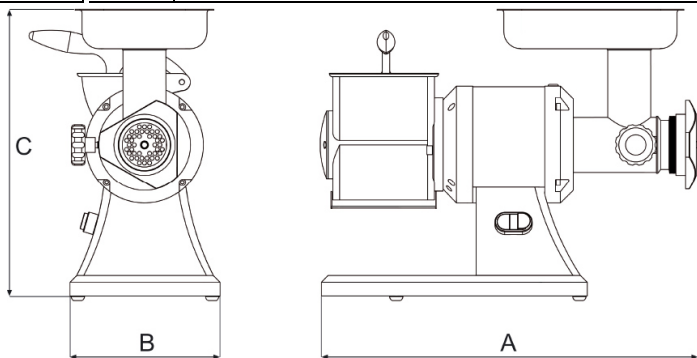

Livello di potenza acustica continuo equivalente ponderato A	Minore di 70dBA
Natura della corrente - Frequenza	Cfr. targa della macchina
Corrente a pieno carico	Cfr. targa della macchina
Tensione nominale d'impiego	Cfr. targa della macchina
Tensione dei circuiti ausiliari	AC 24V - DC 24V
Massa e neutro	TT e TN
Grado di protezione	IP X3
Luogo d'impiego	All'interno
Posizionamento della macchina	Banco di lavoro impiegato nel settore alimentare di altezza compresa tra 900/1100mm dal piano di calpestio di adeguata portata, con uno spazio libero di circolazione di almeno 800mm
Temperatura aria ambiente max	+40°C
Illuminazione minima richiesta	500 lux
Conformità direttive di prodotto	2006/42/CE, Regolamento 1935/2004 e Regolamento 2023/2006