



MOD: PFE-111/S

Production code : EQ-SME911-HS/DI

09/2025

400/3N/ 50-60*Hz

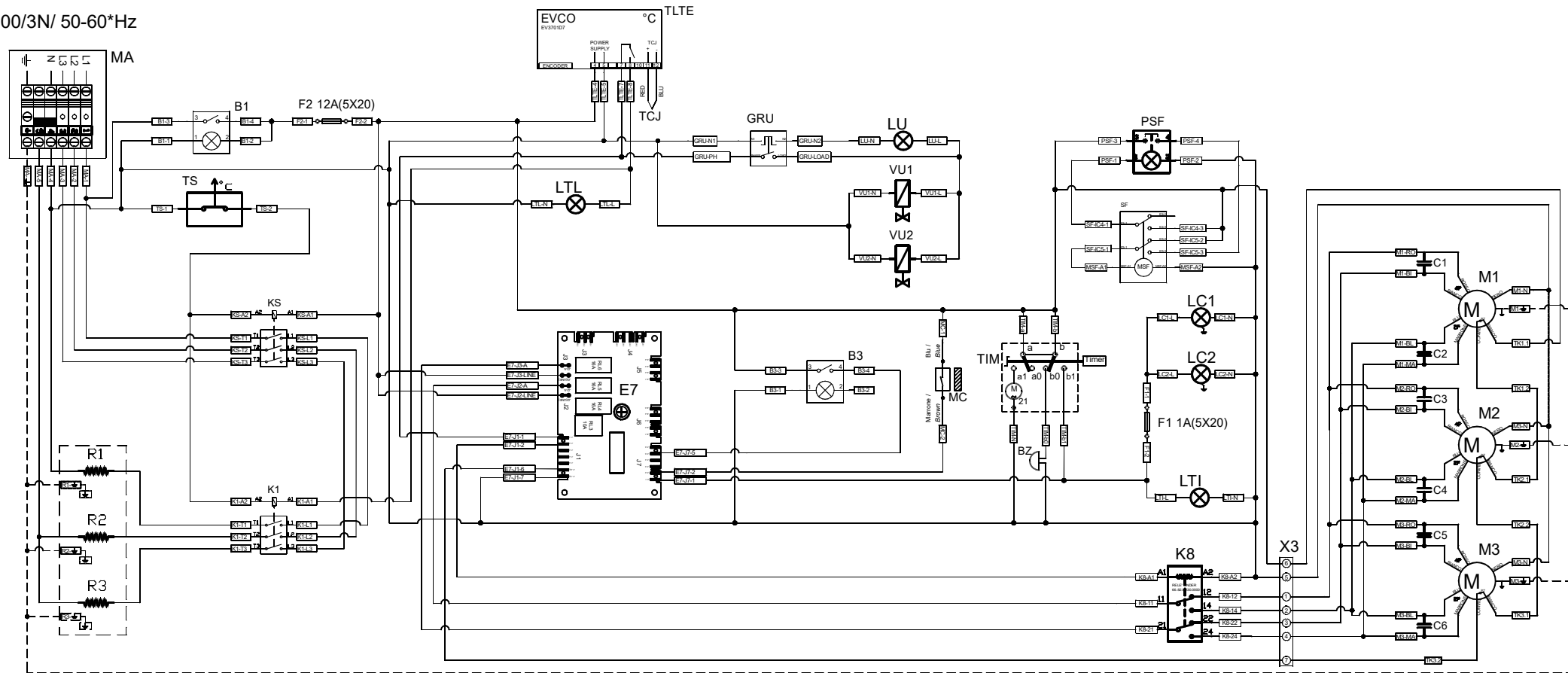

ITALIANO

BZ	BIZZER	MC	LUCE UMIDITA'
B1	INTERRUTTORE GENERALE	MC	MICRO PORTA
B2	INTERRUTTORE SFIATO CAMINO	MTI	MOTORE TIMER
B3	INTERRUTTORE ALTA/BASSA VELOCITA'	MA	MORSETTIERA ALIMENTAZIONE
C1	CONDENSATORE BASSA VELOCITA' MOTORE 1	M1	MOTORE CELLA 1
C2	CONDENSATORE ALTA VELOCITA' MOTORE 1	M2	MOTORE CELLA 2
C3	CONDENSATORE BASSA VELOCITA' MOTORE 2	M3	MOTORE CELLA 3
C4	CONDENSATORE ALTA VELOCITA' MOTORE 2	MS	MOTORE VENTOLA RAFFREDDAMENTO 1
C5	CONDENSATORE BASSA VELOCITA' MOTORE 3	MSF	MOTORE MOTORIDUTTORE SFIATO
C6	CONDENSATORE ALTA VELOCITA' MOTORE 3	PAB4	MORSETTIERA ALIMENTAZIONE 230V
E7	SCHEDA INVERSORE VENTOLE	PSF	PULSANTE SFIATO CAMINO
F1	FUSIBILE LUCE CELLA	R1	RESISTENZA 1
F2	FUSIBILE AUSILIARIO	R2	RESISTENZA 2
GRU	REGOLATORE ENERGIA UMIDITA'	R3	RESISTENZA 3
KS	CONTATTORE SICUREZZA	SF	MOTORIDUTTORE SFIATO
K1	CONTATTORE RESISTENZA 1	TCJ	TERMOCOPIA TIPO J
K8	RELE' INVERSIONE VENTOLE	TLTE	TERMOSTATO TEMPERATURA
LC1	LUCE CELLA 1	TS1	TERMOSTATO SICUREZZA 1
LC2	LUCE CELLA 2	VU1	VALVOLA VAPORE DIRETTO 1
LTI	LUCE TIMER	VU2	VALVOLA VAPORE DIRETTO 2
LTL	LUCE TEMPERATURA	X3	MORSETTIERA DIRAMAZIONE VENTOLE

ENGLISH

BZ	BZZER	MC	LIGHT HUMIDITY
B1	GENERAL SWITCH	MC	MICRO DOOR
B2	BREATHER SWITCH	MTI	TIMER ENGINE
B3	HIGH / LOW SPEED SWITCH	MA	POWER TERMINAL BOARD
C1	MOTOR LOW SPEED CONDENSER 1	M1	CELL MOTOR 1
C2	HIGH SPEED MOTOR CONDENSER 1	M2	CELL MOTOR 2
C3	MOTOR LOW SPEED CONDENSER 2	M3	CELL MOTOR 3
C4	HIGH SPEED MOTOR CONDENSER 2	MS	COOLING FAN MOTOR 1
C5	MOTOR LOW SPEED CONDENSER 3	MSF	BREATHER ENGINE
C6	HIGH SPEED MOTOR CONDENSER 3	PAB4	TERMINAL BLOCK 230V POWER SUPPLY
E7	INVERSOR FAN BOARD	PSF	CHIMNEY VENT BUTTON
F1	CELL LIGHT FUSE	R1	RESISTANCE 1
F2	AUXILIARY FUSE	R2	RESISTANCE 2
GRU	ENERGY HUMIDITY REGULATOR	R3	RESISTANCE 3
KS	SECURITY CONTACTOR	SF	VENT MOTOR
K1	RESISTANCE CONTACTOR 1	TCJ	TYPE J THERMOCOUPLE
K8	FAN REVERSE RELAY	TLTE	TEMPERATURE TELETERMOSTAT
LC1	CELL LIGHT 1	TS1	SAFETY THERMISTAT 1
LC2	CELL LIGHT 2	VU1	DIRECT STEAM VALVE 1
LTI	TIMER LIGHT	VU2	DIRECT STEAM VALVE 2
LTL	LIGHT TEMPERATURE	X3	FAN BRANCH TERMINAL BLOCK

400/3N/ 50-60*Hz

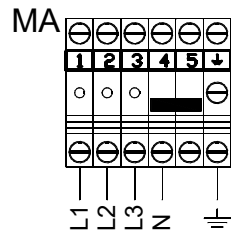

10 TRAYS MODEL

*60Hz ONLY REQUEST

230/3/ 50-60*Hz

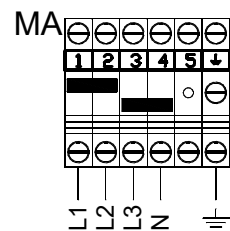

*60Hz ONLY REQUEST

COD.8540410

COD.

PFE-111/S