



MOD: AL4S/FGCB

Production code : AT07N2500+KAR0033+KAR0027

09/2025

DRY-AGING MEAT CABINET

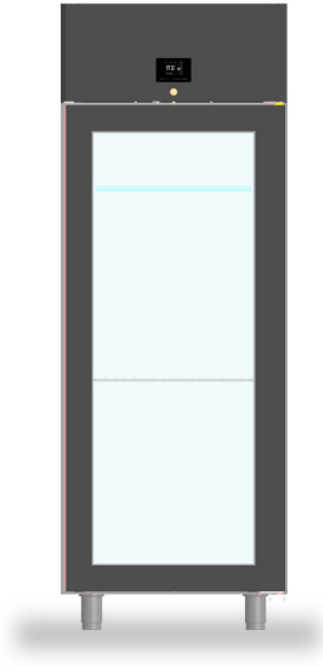

UK

**INSTALLATION, OPERATING AND MAINTENANCE
INSTRUCTIONS**



1. INDEX

1. INDEX.....	1
2. ANALYTICAL INDEX.....	2
3. SAFETY.....	3
4. REGULATIONS AND GENERAL INSTRUCTIONS.....	5
4.1. General information.....	5
4.2. Warranty.....	5
4.3. Replacement of Parts.....	6
4.4. Description of the Appliance.....	6
4.5. Features Plate.....	7
4.6. Personal Protective Equipment.....	8
4.7. Further risks.....	8
5. TRANSPORT AND STORAGE.....	9
5.1. General Information	9
5.2. Transport and Handling	9
5.3. Storage	9
6. INSTALLATION.....	10
6.1. Packaging And Unpacking.....	10
6.2. Installation.....	11
6.3. Electric Power Supply Connection.....	13
6.4. Inspection.....	13
7. USE AND FUNCTIONING.....	14
7.1. First Switching.....	14
7.2. Seasoning Cycle.....	14
7.3. AUX Auxiliary Functions.....	16
7.4. Settings.....	16
7.5. Service.....	17
7.6. Recommendations for Use.....	18
8. CLEANING AND MAINTENANCE.....	18
8.1. Recommendations for Cleaning and Maintenance.....	18
8.2. Routine Maintenance.....	19
8.3. Extraordinary maintenance.....	19
8.4. Maintenance intervals.....	20
9. FAULTS.....	21
9.1. Alarms Display.....	22
10. TECHNICAL NOTES.....	23
10.1. Accessory wheels assembly kit.....	23
10.2. Reversibility of the Doors.....	24
11. DISPOSAL OF THE APPLIANCE.....	25
11.1. Waste storage	25
11.2. Equipment disassembly procedure	25
12. TECHNICAL DATA SHEET OF REFRIGERANT R134a/R452A.....	26
13. TECHNICAL DATA SHEET OF REFRIGERANT R290.....	26
ATTACHMENTS.....	I

2. ANALYTICAL INDEX

A

Accessory wheels assembly kit; 23
AUX Auxiliary Functions; 16

C

Cabinet Probe Alarm; 22

D

Description of the Appliance; 6
Disposal of the Appliance; 25

E

Electric Power Supply Connection; 13
Evaporator Probe Alarm; 22

F

FAULTS; 21
Features Plate; 7
First Switching; 14
Further Risks; 8

G

General information; 5
General Information; 9

H

Humidity Probe Alarm; 22

I

Inspection; 13
Installation; 11

M

Maintenance intervals; 20

O

Open Door signal; 22

P

Packaging; 10
Personal Protective Equipment; 8
Prolonged Inactivity; 18

R

Recommendations for Cleaning and Maintenance;
18
Recommendations for normal use; 18
Recommendations for Use; 18
Replacement of Parts; 6
Reversibility of the Doors; 24
Routine Maintenance; 19
RTC Alarm; 22

S

SAFETY; 3
Seasoning Cycle; 14
Service; 17
Settings; 16
Storage; 9

T

Technical Data Sheet of Refrigerant R134a /
R452A; 26
Technical Data Sheet of Refrigerant R209; 26
Transport and Handling; 9

U

Unpacking; 10
USE AND FUNCTIONING; 14

W

Warranty; 5

To highlight certain parts of the text of considerable importance or to indicate certain important specifications, special symbols have been adopted, the meaning of which is described below:



Indicates important information regarding safety. Behave appropriately so as not to risk the health and safety of persons or cause damage.



Indicates particularly important technical information that must not be ignored.

3. SAFETY



It is recommended to carefully read the instructions and warnings contained in this manual before using the appliance. The information contained in the manual is fundamental for the safety of use and for machine maintenance.



Keep this manual carefully so that it can be consulted when necessary. In case of transfer of the equipment, provide the new user with this booklet.



Please contact the manufacturer if you do not fully understand the contents of this manual.



The electric plant has been designed in compliance with the **IEC EN 60335-2-89** Standard.



Warning: R290 cooling gas is potentially flammable and explosive. Every possible safety precaution must be taken to avoid any danger.



Installation, extraordinary maintenance and disposal of the equipment must be performed by qualified personnel, in accordance with the regulations in force in the country of use and in compliance with the regulations relating to installations and safety at work.



The sound pressure level emitted by the equipment is less than 70dB (A). The value may increase depending on the workplace where it is measured.



Maintain ventilation openings in the appliance casing or in the built-in structure free from all obstructions.



Do not use mechanical devices or other means to accelerate the defrosting process, other than those recommended by the manufacturer.



Do not damage the coolant circuit.



Do not use electrical appliances inside the appliance compartments for storage of frozen food.



Do not store explosives, such as pressurised containers with flammable propellant, in this unit.





This equipment is not suitable for storing pharmaceutical, chemical or non-food grade products.





This equipment has not been designed to be installed in a potentially explosive atmosphere.

 Do not place anything on the bottom of the device. Use the appropriate racks to store the product.

 The maximum permissible load for the racks is 45kg evenly distributed.

 Replacement of the power cord must be performed by qualified personnel.

 Specific adhesives highlight the presence of mains voltage in the proximity of areas (however protected) with risks of an electrical nature.

 Before connection, ensure that the means for disconnecting the equipment from the mains are incorporated into the fixed installation in accordance with the installation rules (required for equipment supplied without a plug to be connected to a permanent installation).

 During the installation of the equipment, it is not allowed the transit or the permanence of people not involved in the installation near the working area; use individual protection devices (gloves, safety shoes, etc.) and operate in compliance with the rules related to the safety at work.

 In the design and construction phase, the manufacturer has paid particular attention to the aspects that can cause risks to safety and health of persons that interact with the equipment.

 Carefully read the instructions in the manual provided and those applied directly, especially those concerning safety.

 Do not tamper with, evade, eliminate or bypass the installed safety devices. Failure to comply

with this requisite can lead to serious risks for personal health and safety.

 It is recommended to simulate some test manoeuvres to identify the controls, in particular those relative to switch-on and switch-off and their main functions.

 The appliance is only destined for the use for which it has been designed; any other use must be considered improper.

 The manufacturer declines all liability for any damage to objects or injury to persons owing to improper or incorrect use.

 All maintenance interventions that require precise technical skill or particular ability must be performed exclusively by qualified staff.

 Do not under any circumstances stress the power cable.

 The safety devices must be subjected to periodic inspections as indicated in the chapter on extraordinary maintenance.

 In order to guarantee hygiene and protect the foodstuffs from contamination, the elements that come into direct or indirect contact with the foodstuffs must be cleaned very well along with the surrounding areas. These operations must only be performed using detergents that can be used with foodstuffs, avoiding inflammable products or those that contain substances that are harmful to personal health.

 In the case of prolonged inactivity, as well as disconnecting all the supply lines, it is necessary to accurately clean all internal and external parts of the appliance.

4. REGULATIONS AND GENERAL INSTRUCTIONS

4.1. General information

 This manual has been designed by the manufacturer to provide the necessary information to those who are authorised to interact with the equipment.

 The persons receiving the information must read it carefully and apply it strictly.

 Reading the information contained in this document will allow the user to prevent risks to personal health and safety.

 Keep this manual for the entire operating life of the equipment in a place, which is well known and easily accessible, so that it is always available when its consultation becomes necessary.

The equipment has been designed for the refrigeration of food. Any other use is considered improper.

 The equipment is not intended for use by:

- persons whose physical, sensory or mental capabilities are impaired.
- children
- persons with a lack of experience and/or knowledge of the product/process.

 The equipment is not suitable for installation outdoors and/or in environments subject to the action of atmospheric agents (sun, rain, etc.).

4.2. Warranty

The warranty of the appliance and the components we produce has duration of 2 years from the date of delivery and translates into the supply, free of charge, of parts that we consider to be faulty. These faults must, however, be independent from incorrect use of the product in compliance with the indications stated in the manual.

Fees deriving from labour, journeys and transport are excluded from the warranty.

The materials replaced under warranty are our property and must therefore be returned under the responsibility and expense of the customer.

4.3. Replacement of Parts

⚠ Activate all envisioned safety devices before carrying out any replacement intervention.

i In particular, deactivate the electrical power supply using the differential isolating switch. Only use original spare parts to replace worn components.

i The manufacturer is not liable for damage or malfunctions caused by:

- non-compliance with the instructions in this manual;
- repairs not performed in a workmanlike manner;

- use of non-original spare parts;
- interventions by non-skilled technicians;
- unauthorised intervention;
- lack of preventive maintenance;
- improper use of the equipment
- unforeseeable events
- use of the equipment by insufficiently trained staff
- non-application of the safety and hygiene regulations in force in the country of use.

i We accept no liability for damage caused by conversions and/or modifications made by the end user.

4.4. Description of the Appliance

The refrigerated cabinet, from now on defined as appliance, has been designed and built to preserve foodstuffs in the professional catering ambit.

- 1) condensation area:** it is positioned in the upper part and is characterised by the presence of the condensing unit.
- 2) electric area:** it is positioned in the upper/front part and contains the control and power supply appliance as well as electric wiring.
- 3) cooling/heating area:** one is located in the cell compartment of the cooling unit and another in the heating unit.
- 4) storage area:** it is situated under the evaporating unit and is destined for preservation of foodstuffs.

The upper part is characterised by a dashboard that allows access to the electric parts.

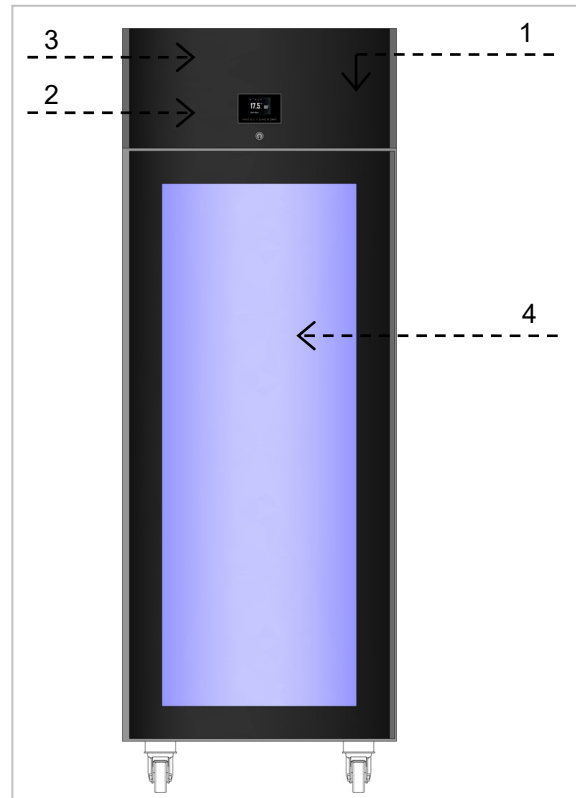

In the front part, there is one vertically opening door, which closes the refrigerated compartment hermetically.



4.5. Features Plate

The identification plate shown is applied directly onto the appliance. It states the references and all indications indispensable for working in safety.

- 1) Appliance code
- 2) Description of the appliance
- 3) Serial number
- 4) Power supply voltage and frequency
- 5) Rated output
- 6) Defrosting output
- 7) Total light output
- 8) Climatic class
- 9) Type and Amount of refrigerant gas
- 10) Number of the refrigerant of the main component of the foam insulation gas
- 11) WEEE symbol

2018		
Code Kode Codice	XXXXXXXXXX	①
Descrizione / Description	XXXXXXXXXX XXXXXXXXX	②
Serial No./ Serien Nr./ Matricola	XXXXX.XXXXX	③
Tension / Spannung / Tensione	xxx V~ xx Hz	④
Input / Leistungsaufnahme / Potenza	xxx W xxx A	⑤
 Defrost Power / Potenza Sbrinamento	xxx W	⑥
Climate Class / Klimaklasse / Classe Climatica	5	⑧
Refrigerant Kuehlmittel Refrigerante	xxxx xxxx Kg	⑨
Insulation Isolierung Isolamento	HFO1233zd	⑩
⑪		CE
	Max  xx W	⑦

GB

The climate class described on the identification plate refers to the following values:

Blind door models

Climate Class	EN 60335-2-89	EN ISO 23953	
	Room Temperature	Room Temperature	Relative Humidity
5	43°C	40°C-	40%
4	32°C	30°C-	55%

Glass door models

Climate Class	EN 60335-2-89	EN ISO 23953	
	Room Temperature	Room Temperature	Relative Humidity
4	32°C	30°C-	55%

4.6. Personal Protective Equipment

The identification and selection of appropriate personal protective equipment is the responsibility of the employer or workplace manager or service technician.

Operators are required to wear the identified equipment.

Durante l'uso ordinario, i guanti proteggono le mani dalla teglia fredda.

Di seguito l'elenco dei principali dispositivi di protezione individuale (DPI) da utilizzare durante le varie operazioni di lavoro.

Task	Protective clothing	Safety shoes	Gloves	Glasses	Helmet or hard hat
Transport and handling		■	□		□
Unpacking		■	□		
Assembly		■	□		
Ordinary use	■	■	□		
Ordinary cleaning	□	■	■	□	
Extraordinary cleaning	□	■	■	□	
Maintenance	□	■	□		
Dismantling	□	■	□		
Scrapping	□	■	□		

■ Mandatory personal protective equipment (MPPE)

□ Personal protective equipment (PPE) to be used if necessary

4.7. Further risks

The proper design of the equipment and the installation of adequate protection do not completely exclude risks to the operator.

This manual lists the personal protective equipment to be used by the operator.

Sufficient space is provided during the installation of the equipment to limit the risks. To maintain

these conditions, the areas surrounding the equipment must be kept clean, dry, well lit and free of obstacles.

The following is a list of possible risks that may still occur.

Possible risks	Description
Slip or fall	The operator may slip due to water, oil or dirt on the floor.
Burns Abrasion	The user intentionally or unintentionally touches certain components inside the appliance (e.g. cold pans, cooling fins and cooling circuit tubes) without wearing protective gloves.
Electrocution	Description
Fall	Contact with live electrical parts during maintenance operations performed without disconnecting the power supply.
Injuries	The operator intervenes on the equipment using unsuitable means to access the upper part.
Tipping	The upper control panel may not be secured properly by qualified personnel. It may close abruptly.
Cooling gas	During equipment and packaging handling operations using unsuitable lifting and/or handling equipment or with an unbalanced load
Slip or fall	Inhalation of cooling gas. The type of refrigerant can be found on the equipment's identification plate.

5. TRANSPORT AND STORAGE

5.1. General Information

The equipment must be transported and handled using appropriate means with adequate capacity.

 During transport and handling of the equipment, it is strictly forbidden to stack one machine on top of the other, in order to exclude the risk of loads tipping over due to stacking.

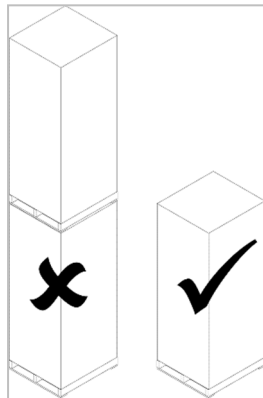

 The equipment must only be transported, handled and stored by skilled staff. Minimum requirements for skilled staff are as follows:

- specific technical training and experience in the use of lifting systems;
- knowledge of safety regulations and applicable laws;
- knowledge of general safety requirements;
- respect for the use of personal protective equipment in accordance with the operation performed;
- the ability to identify in advance and avoid any possible danger.

5.2. Transport and Handling

 It is forbidden to stand under suspended loads during handling and transport. Unauthorised personnel may not enter the work area. The transported load can move when braking, accelerating, cornering and on rough roads.

 The equipment must be handled in a vertical position. It is forbidden to move the equipment in a horizontal position. If the equipment is handled in a horizontal position, wait a few hours before operating it.

For the correct performance of lifting operations, use the most suitable type of equipment in terms of characteristics and load capacity: forklift or transpallet.

 Avoid pushing or dragging the equipment when handling it.

 Before lifting, secure the surrounding area and prevent access to personnel. Move the equipment to a minimum height above the ground and ensure the stability of the load.

 Do not lift the equipment in any other way than explained in this manual. Before placing the load, check that the floor is level and has sufficient load-bearing capacity to support the weight of the load.

5.3. Storage

 The equipment must be stored in a non-aggressive, vibration-free environment.

 The room temperature should be between -10°C and +50°C. Avoid excessively humid environments. The storage place must have an

adequate support surface to prevent deformation of the machine or damage to the support feet.

 Only skilled staff is allowed to perform positioning, assembly and disassembly of the equipment.

6. INSTALLATION

6.1. Packaging And Unpacking

Move and install the appliance respecting the information provided by the manufacturer, shown directly on the packaging, on the appliance and in this manual.

 Wear protective gloves before unpacking.

 Avoid pushing or dragging the equipment to avoid risks of tipping over and damage to the structure.

The lifting and transportation system of the packaged product envisages the use of a fork-lift truck or a pallet stacker, using which particular attention must be paid to balancing the weight in order to prevent the risk of overturning (avoid excessive tilting!).

 **ATTENTION:** When inserting the lifting device, pay attention to the gas supply pipe and the position of the feet.

 **ATTENTION:** given the presence of weights concentrated in the high part of the appliance, do not drag the appliance during movements (tipping hazard and damage to feet).

The packaging is made of cardboard and the pallet of wood. A series of symbols is printed on the cardboard packaging, which highlights, in accordance with international standards, the provisions that the appliances must be subject to during loading, unloading, transportation and storage.

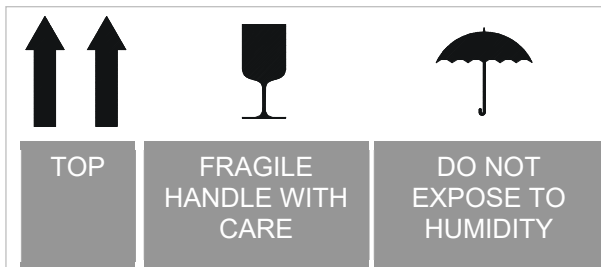

On delivery, check that the packaging is intact and has not suffered any damage during transportation. Any damage must be notified to the transportation company immediately.

The appliance must be unpacked as soon as possible to check that it is intact and undamaged. Do not cut the cardboard with sharp tools in order to prevent damage to the steel panels underneath. Pull the cardboard packaging upwards. After having unpacked the appliance, check that the features correspond to those requested in the order.

For any anomalies, connect the dealer immediately.

 On stainless steel equipment, carefully remove the protective film from the inner and outer walls, avoiding the use of metal tools.

If adhesive remains on the walls of the machine, remove it using a non-corrosive solvent; rinse and dry thoroughly after cleaning. It is advisable to apply a protective oil layer to all steel surfaces.

 Packaging elements (nylon bags, polystyrene foam, staples ...) must not be left within reach of children.

Remove the protective PVC film from the internal and external walls, avoiding the use of metal tools.

 Inside the cooling compartment, guides for the tray are located at the bottom.

 Packaging must be disposed of in accordance with the regulations in force in the country where the equipment is used.

6.2. Installation

 Installation and assembly operations must be carried out by qualified professionals. If the equipment uses R290 cooling gas, every possible precaution must be taken to avoid any danger linked to the flammability of this gas.

 All the installation phases must be considered, from the moment of creation of the general plan.

 Installation and assembly operations must be carried out in accordance with current safety regulations.

 The equipment used for installation and assembly operations must comply with current safety standards. The installation area must be equipped with all power supply and production residue drainage connections and must be suitably lit and respect current laws regarding hygiene and sanitary requirements.

 To optimise consumption and reduce wear of the machine, do not position it in the vicinity of heat sources or in environments where temperatures are too high. Proceed with appliance levelling, acting on the individual feet.

 It is essential that the equipment is level; otherwise, the operation of the machine may be impaired

Install the equipment so that the workstation is positioned in front of the control panel.

 Do not push or drag the appliance during installation to avoid its tipping over or causing damage to parts or persons.

 This appliance can only be installed and operate in rooms, which are permanently ventilated, in order to guarantee correct operation.

 Connect and leave for a certain period of time (at least 2 hours) before checking functioning. During transport, it is probable that the compressor lubricant oil has entered the refrigerant circuit blocking the capillary: therefore, the appliance will function for a certain period without producing cold until the oil has returned to the compressor.

 The size of the compartment that houses the equipment must be such as to avoid excessive concentrations of gas in the event of a leak from the refrigeration circuit and in any case, the compartment must have a free area NEVER smaller than 4 times the space occupied by the equipment. Adequate space must be provided to ensure effective escape routes at all times. The above-mentioned compartment must be well ventilated.



ATTENTION: the appliance requires the minimum functioning spaces as shown in the diagram.

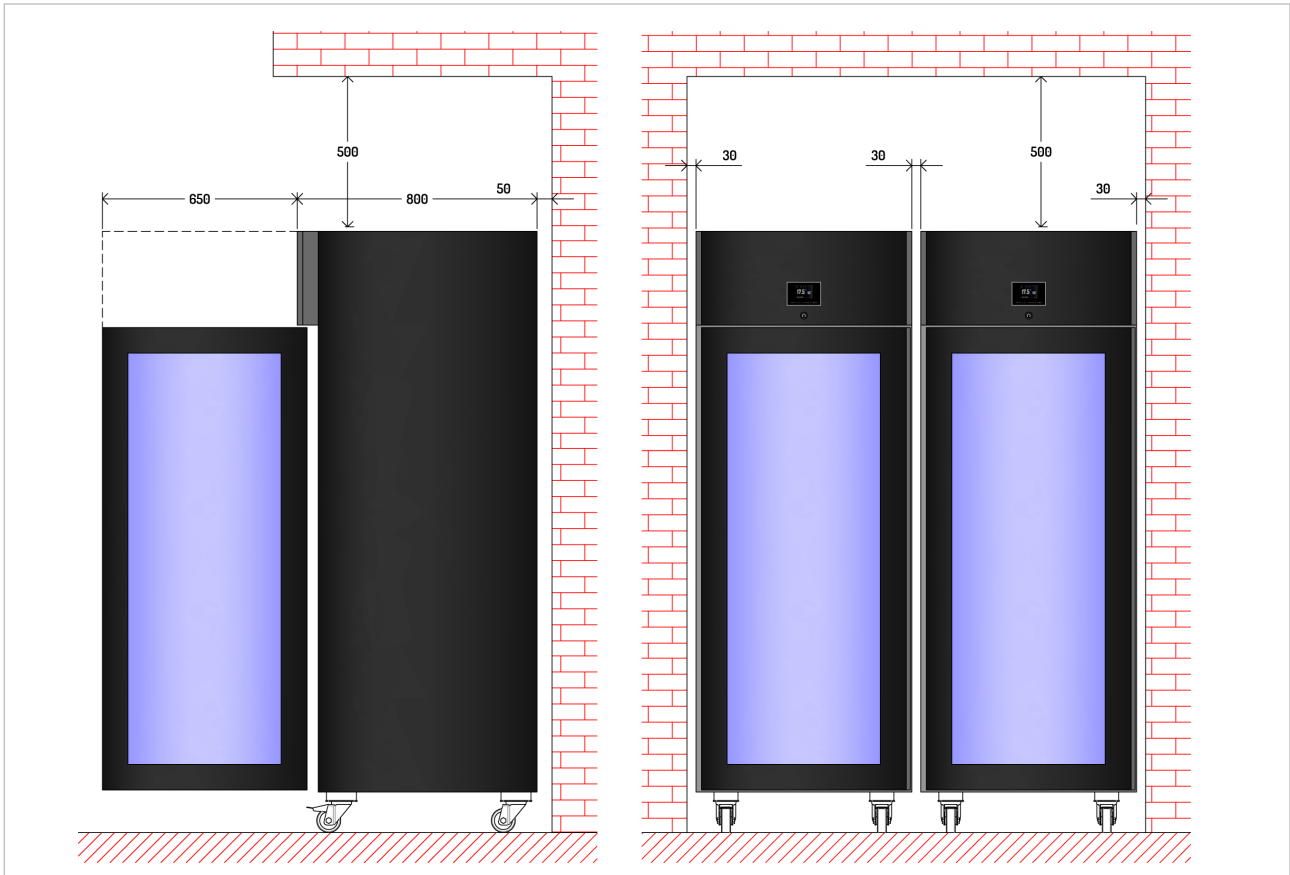

GB

6.3. Electric Power Supply Connection

Connection must be carried out by authorised and qualified staff, respecting the current laws regarding the subject and using appropriate prescribed material.

 Before connecting the appliance to the electric mains check that the voltage and the frequency correspond to the data stated on the registration plate applied on the rear of the appliance.

 The equipment is supplied with one of the following operating voltages:

- 230V 1~ 50Hz
- 220V1~ 60Hz.

 Provide an earthed socket with a capacity appropriate to the absorption indicated on the identification plate.

 It is forbidden to operate the equipment connected to an ungrounded system.

 For direct connection to the power supply, a device must be provided to ensure disconnection from the power supply, with a contact-opening distance allowing complete disconnection under the conditions of overvoltage category III, in accordance with the installation rules.

 Refer to the technical data on the identification plate for the correct sizing of the switch.

 The switch-disconnector must be located close to the equipment, must be visible to the operator and must be indicated by an information sign.

 If a plug is used, it must comply with national installation regulations.

 The plug must be accessible even after the equipment has been placed in the installation location.

 The plug must always be visible to the operator performing the maintenance operation.

After the electrical connection, check that the supply voltage, when the equipment is running, does not deviate from the nominal value given on the specifications plate $\pm 10\%$.

The power cable used for connection to the mains supply is of type H05VV-F; when replacing it, use a cable with the same or better characteristics.

 When replacing the power cable, the earth conductor must be kept longer than the active conductors.

 The replacement of a damaged power cable must be done by a qualified technician in order to prevent any possible risk.

6.4. Inspection

The appliance is delivered in conditions that it can be started-up by the user.

This functionality is guaranteed by passing the tests (electric inspection - functional inspection,

appearance inspection) and relative certification through the specific attachments.

7. USE AND FUNCTIONING

7.1. First Switching

At the first switching of the machine, the device displays the ON / Standby screen.

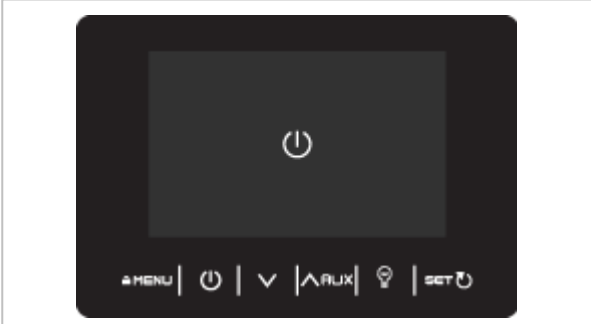

To turn the device on, from the ON/Stand-by screen, press the central area to show the Home screen.

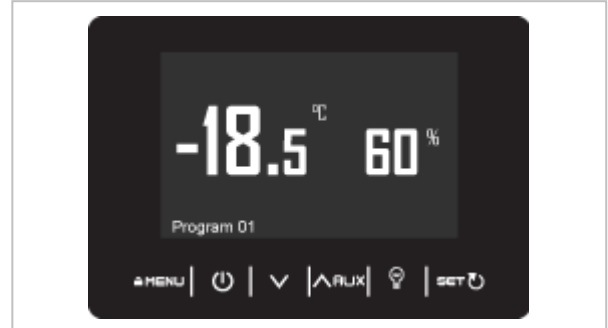

From the Home screen, it is possible to enter the functioning mode of the machine simply selecting the desired area.

To switch the device off, press the area  on the Home screen.

7.2. Seasoning Cycle

To select one of the 6 available programmes, press the  key:



Select an available programme and press the  key to confirm.





To start the selected cycle, press .

During an ongoing cycle, the display shows the temperature and humidity read by the cell probe. The status of the main functions are displayed through icons at the top of the screen.

Find below their meaning when turned on:

	Compressor on
	Heating on
	Evaporator fans on
	Defrosting in progress
	Humidification in progress
	Dehumidification in progress
	Energy saving on
	Maintenance needed
	Light on by key

	Seasoning cycle in progress
	Alarm in progress
HACCP	HACCP alarm detected

During an ongoing cycle, it is possible to change the setting values of the individual phase by pressing the **SET**  key.

The values that can be changed are:

- cell temperature
- humidity percentage
- phase duration in hours and minutes

To change the selected programme, press the **MENU**  key for at least two seconds:







Select the first entry in the list using the **SET**  key.

Each programme consists of the following cycles:

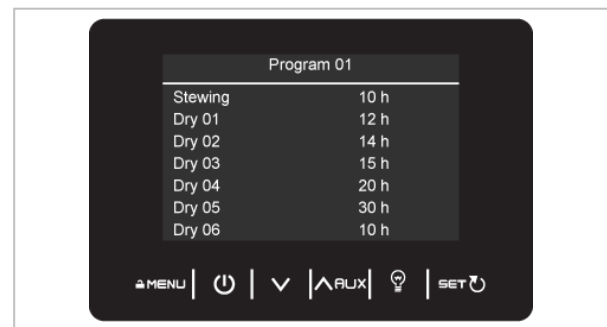
Stewing or dripping	
Drying	01
Drying	02
Drying	03
Drying	04

Drying	05
Drying	06
Seasoning	





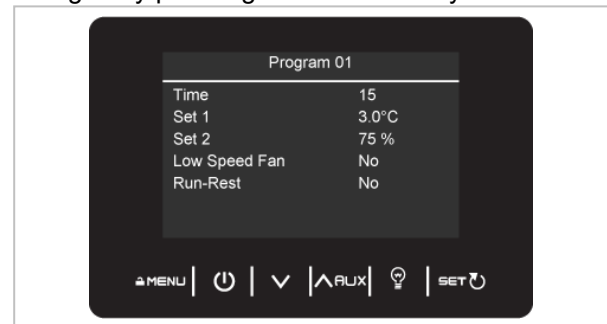

Scroll through the different phases using the  and **AUX**  keys; adjustment values can be changed by pressing the **SET**  key:



Press  to go back to the previous screen.

At the end of the programme, the display shows END, the adjustment proceeds until the manual stop with the key .

A programme in progress can be interrupted by pressing the  key for at least three seconds.

programme		1	2	3	4	5	6
Temperature		2°C	2°C	2°C	2°C	2°C	2°C
Humidity		80%	80%	80%	80%	80%	80%
Duration		15 d	20 d	25 d	30 d	35 d	40 d

7.3. AUX Auxiliary Functions

Press the **AUX** key to access the AUX menu.

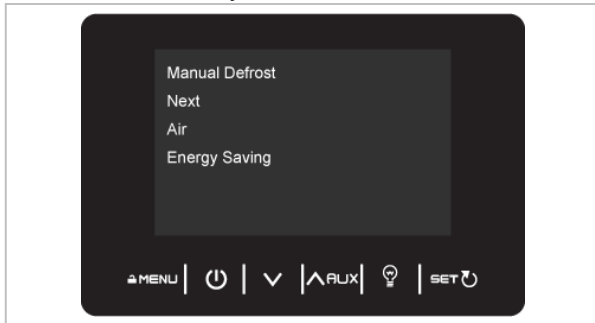

The following options are available.

➤ **Manual Defrost**

If conditions permit, the instrument performs a manual defrost.

➤ **Next**

The instrument interrupts the current phase and skips to the next phase.

➤ **Air**

Function not used

➤ **Energy saving**

Enables the energy saving function by changing the temperature setpoint (setpoint + 1°C).

7.4. Settings

From the home screen, pressing the **MENU** key for at least two seconds calls up the settings menu:

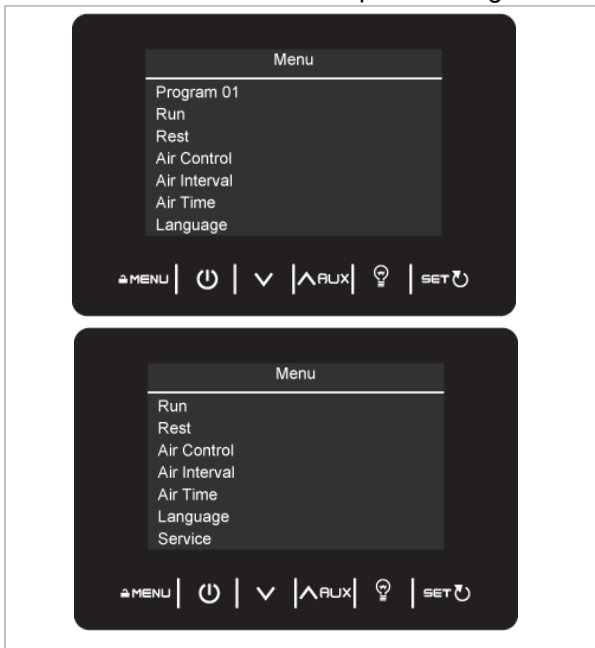

Scroll through the available entries using the **down arrow** and **AUX** keys.

Following options are available.

➤ **Program 0x**

Selecting the Program entry allows the parameters for temperature, humidity and duration of the individual seasoning phases to be changed.

Temperature and humidity set changes are immediate in the current programme, while they are stored in the programme if P32=1.

➤ **Run and Recovery - rest (function not used)**

During the stewing, drying and seasoning cycle, a working phase and a rest phase can be established. In the rest phase, all utilities remain switched off.

Select the **Run** entry to set the duration of the working phase; select the **Reheating** entry to set the resting phase.

➤ **Control, interval and air exchange (function not used)**

An internal air exchange can be enabled during the stewing, drying and seasoning cycle.

By selecting the **air control** entry, it can be decided whether the function is active:

0 = active in all 3 processes (default)

1 = active in processes 1 Stewing and 2 Drying

2 = active in processes 2 Drying and 3 Seasoning

3 = active in processes 1 Stewing and 3 Seasoning

The entries **Air Interval** and **Air Change** allow the setting of the interval and duration of the internal air change respectively.

➤ **Languages**

The following languages are available: ITALIANO, ENGLISH, FRANÇAIS, DEUTSCH, ESPAÑOL, PORTUGUÊS. To select the desired language tap near to it.

7.5. Service

From the home screen, pressing the **MENU** key for at least two seconds calls up the settings menu:

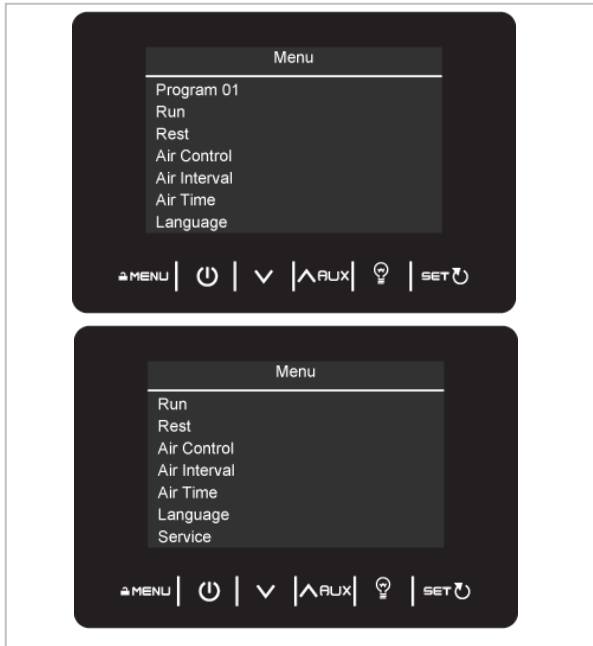

Scroll through the available entries using the **ALUX** keys and select **Service**.

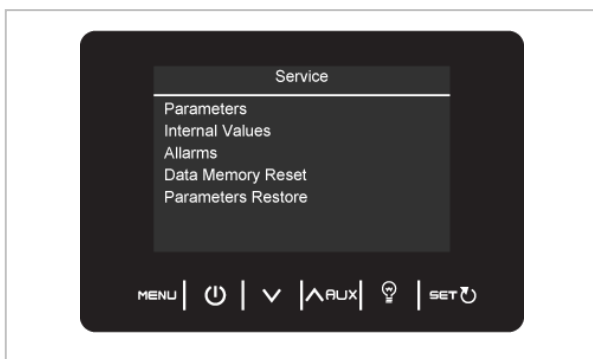

Following options are available.

➤ Parameters

The selection of **parameters** entry allows the modification of machine configuration parameters. The function is password-protected. Entering the password value **1** gives access to a limited set of parameters for adjustment and setting tasks. Entering the password value **-19** gives access to all adjustment and configuration parameters.

➤ Internal Values

Selecting the entry **Internal Values** allows the display of the values read by the temperature and humidity probes, the compressor operating hours and the number of door openings during the day.

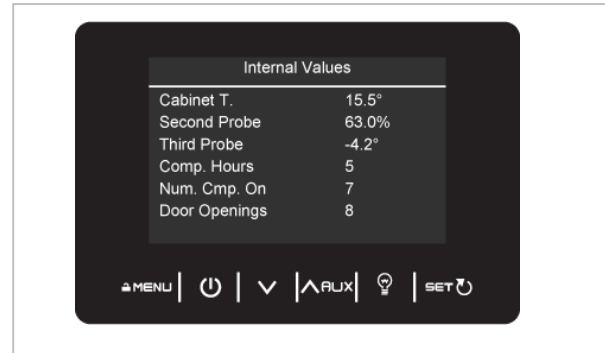

➤ Alarms

Selecting the **Alarms** entry allows the display of stored alarms.

If there are no stored alarms, the display shows 'No Alarms'.

➤ Data Memory Reset

Selecting the entry **Data Memories Reset** allows the complete deletion of stored alarms.

The function is password-protected: **149**.

➤ Parameters Restore

Selecting the entry **Parameters Restore** allows the complete deletion of all data stored in the instrument and the restoration of the initial parameters.

The function is password-protected: **149**.

➤ Clock (Option)

If the instrument is connected to an external EVLINK control module, the clock can be set in the RTC section.

Press **SET** and set the year YY;

Press **SET** and set the month MM;

Press **SET** and set the day DD;

Press **SET** and set the hour;

Press **SET** and set the minutes;

Press to exit.

7.6. Recommendations for Use

Prolonged Inactivity

If the appliance remains inactive for a long period, proceed as follows:

1. Use the automatic disconnecting switch to deactivate connection to the main electrical line.
2. Clean the appliance and surrounding areas thoroughly;
3. Spread a thin layer of cooking oil onto the stainless steel surfaces;
4. Carry out all maintenance operations;
5. Leave the doors ajar to prevent the formation of mould and/or unpleasant odours.

Recommendations for normal use

In order to ensure correct use of the appliance, it is advisable to apply the following recommendations:

- Do not obstruct the front and rear zones above the condensing unit in order to favour heat disposal from the condenser to a maximum.

- Always keep the front of the condenser clean using a soft brush and do not use rigid or metal tools that may damage the condenser fins.
- Check the planarity of the appliance rest surface.
- Do not introduce liquid or solid substances at temperatures above the environmental temperature and, however, introduce the material after the appliance has reached the functioning temperature.
- Do not stack the materials to be preserved in contact with the internal walls, so blocking the circulation of air, which guarantees uniformity of the internal temperature of the refrigerated compartment.
- Limit the number of times and the duration of time the doors are open to a maximum.

8. CLEANING AND MAINTENANCE

8.1. Recommendations for Cleaning and Maintenance



Activate all envisioned safety devices before carrying out any maintenance interventions. In particular, deactivate the electrical power supply using the automatic isolating switch. During maintenance, the cable and plug must be visible to the operator performing the operation. Do not touch the equipment with wet or damp hands or bare feet.

Do not remove safety guards. Use appropriate personal protective equipment. During maintenance, there are still some risks that cannot be avoided and which must be neutralised by adopting appropriate behaviour. It is forbidden to carry out inspection, cleaning and/or maintenance operations on moving parts.

8.2. Routine Maintenance

Routine maintenance consists of daily cleaning of all the parts which can come into contact with foodstuffs and the periodic maintenance of the burners, nozzles and draining pipes.

Correct maintenance allows the user to maximise performance levels and operating life and constantly maintain safety requirements.

Do not spray the appliance with direct jets of water or high pressure appliances.

When cleaning stainless steel, do not use iron wool, brushes or scrapers as ferrous particles could be deposited which, on oxidising, could lead to rust.

To remove hardened residues, use wooden or plastic spatulas or abrasive rubber pads.

During long periods of inactivity, spread a protective layer on all stainless steel surfaces by wiping them with a cloth soaked in Vaseline oil and airing the rooms periodically.



Do not use products, which contain substances, which are harmful and dangerous for personal health (solvents, petrol etc.).

8.3. Extraordinary maintenance



Extraordinary maintenance operations must be carried out by skilled technical staff, equipped with all personal protective devices.



It is forbidden to remove or tamper with guards and safety devices while the machine is running.



Procedures for topping up the refrigerant and repairing gas leaks may only be carried out by personnel who meet all the requirements of the regulations in force in the country where the equipment is used.



In the case of flammable refrigerant gases, R290, R600a or other hydrocarbons, disconnect the machine from the power supply and completely purge the refrigerant circuit with an inert gas before proceeding with welding or other work requiring flames or sparks.



For refrigerant gases such as R452A, R134a or other greenhouse gases comply with the

regulations in force concerning the handling of Fgas.



In the event of hazardous situations being observed, e.g. damage and exposure to sharp objects, damage to electrical or thermal insulation, the equipment must not be operated or used and must be secured as soon as possible, preventing access to the surrounding area if necessary.



Periodically have the following operations carried out by specialised staff:

- Periodically clean the condenser using suitable tools (suction device or soft brushes).
- Check the perfect sealing of the door gaskets and replace them if necessary.
- Periodically clean the condensate evaporation tray.
- Check that the electric connections have not loosened.
- Check the efficiency of the electronic board and the probes.
- Check the efficiency of the electrical system

8.4. Maintenance intervals



In order to assure constant efficiency of the equipment, it is advisable to inspect the equipment at intervals indicated in the following table:

Operation	Description	Interval
Routine cleaning	General cleaning of equipment and surrounding work area	daily
Mechanical protections	Inspection of the state of preservation of the external mechanical parts; check for any deformation, loosening or removal	monthly
Control	Check of the mechanical part; check for cracks or deformations; check for tightness of screws; check of the state of preservation of the stickers and danger/information symbols.	yearly
Machine structure	Check tightness of screws, main fasteners, etc.	yearly
Safety signs	Check legibility and state of preservation of signs	yearly
Electrical panel	Checking the state of preservation of electrical components and wiring between the switchboard and electrical components.	yearly
Connecting cable, socket and plug	Check the state of preservation of components (replace if necessary)	yearly
General equipment inspection	Complete general inspection of the equipment	10 years





9. FAULTS

The information shown below aims to help with the identification and correction of any anomalies and malfunctions, which could occur during use. Some of these problems can be resolved by the user. For

the others, precise competency is required and they must therefore only be carried out by qualified staff.

Problem	Causes	Solutions
The refrigerator unit does not start	End of defrosting	It restarts after a pause of three minutes.
	No Voltage	Check plug, sockets, fuses and electric mains
	Other causes	 Contact the after-sales centre.
The refrigerator unit functions continuously, cooling insufficiently	Room too hot	air the environment
	Dirty condenser	clean the condenser
	Insufficient door sealing	check the gaskets
	Insufficient quantity of refrigerant gas	 Contact the after-sales centre.
	Resistances always inserted	 Contact the after-sales centre.
	Condenser fan at a standstill	 Contact the after-sales centre.
	Evaporator fan at a standstill	 Contact the after-sales centre.
The refrigerator unit does not stop	Probe faulty	 Contact the after-sales centre.
	Thermostat fault	 Contact the after-sales centre.
Presence of ice inside the evaporator	Appliance not level	use the adjustable feet to level
	Resistances not functioning	check defrosting activation (only on models with electric defrosting)
Appliance noise	Persistent vibrations	check that there is no contact between the appliance and other objects inside or outside
The electronic board remains off.	Power supply cable incorrectly connected.	Check the electric connection
	Interrupted fuses	Check and replace fuses
The machine does not heat correctly	Protective Klixon (PTRC) interrupted.	Check and replace the component.

9.1. Alarms Display

Problem	Causes	Effects	Solutions
RTC	RTC Alarm Malfunctioning of the internal clock. Time not set	The buzzer is active. The buzzer can be silenced pressing any key. Any running cycle will be stopped and all outputs disabled.	Set the date and the current time.
PROBE 1 FAILURE	Cabinet Probe Alarm Cabinet probe damaged	The buzzer is active. The buzzer can be silenced pressing any key. Any running cycle will be stopped and all outputs disabled.	Check the connection and the integrity of the cabinet probe. If necessary replace it.  Contact the after-sales service Alla scomparsa dell'errore il ciclo riprende.
PROBE 2 FAILURE	Humidity Probe Alarm Humidity probe damaged.	The buzzer is active. The buzzer can be silenced pressing any key. Any cycle that involves the use of the humidity probe will be terminated.	Check the connection and the integrity of the humidity probe. If necessary, replace it.  Contact the after-sales service
PROBE 3 FAILURE	Evaporator Probe Alarm Evaporator probe damaged	The buzzer is active. The buzzer can be silenced pressing any key. The defrostings end time-out (see parameter d3)	Check the connection and the integrity of the evaporator probe. If necessary replace it.  Contact the after-sales service
POWER FAILURE	Power failure alarm		Verify the electrical power supply.
OPEN DOOR	Open Door signal Door opening	The buzzer is active. The buzzer can be silenced pressing any key.	The signal automatically returns once the door is closed.
CONDENSER OVERHEAT	The temperature of the condenser has exceeded the first limit imposed. <ul style="list-style-type: none"> The condenser fan will be turned on The alarm output will be activated. 		 Contact the after-sales service.
COMPRESSOR SHUTDOWN	The temperature of the condenser has exceeded the second limit imposed. <ul style="list-style-type: none"> It will not be allowed either select or start any operating cycle. If the error occurs during an operating cycle, the cycle will be interrupted The alarm output will be activated. 		<ul style="list-style-type: none"> ➤ Air the room. ➤ Clean the condenser. ➤ Check that the fans are working properly.

10.2. Reversibility of the Doors

GB

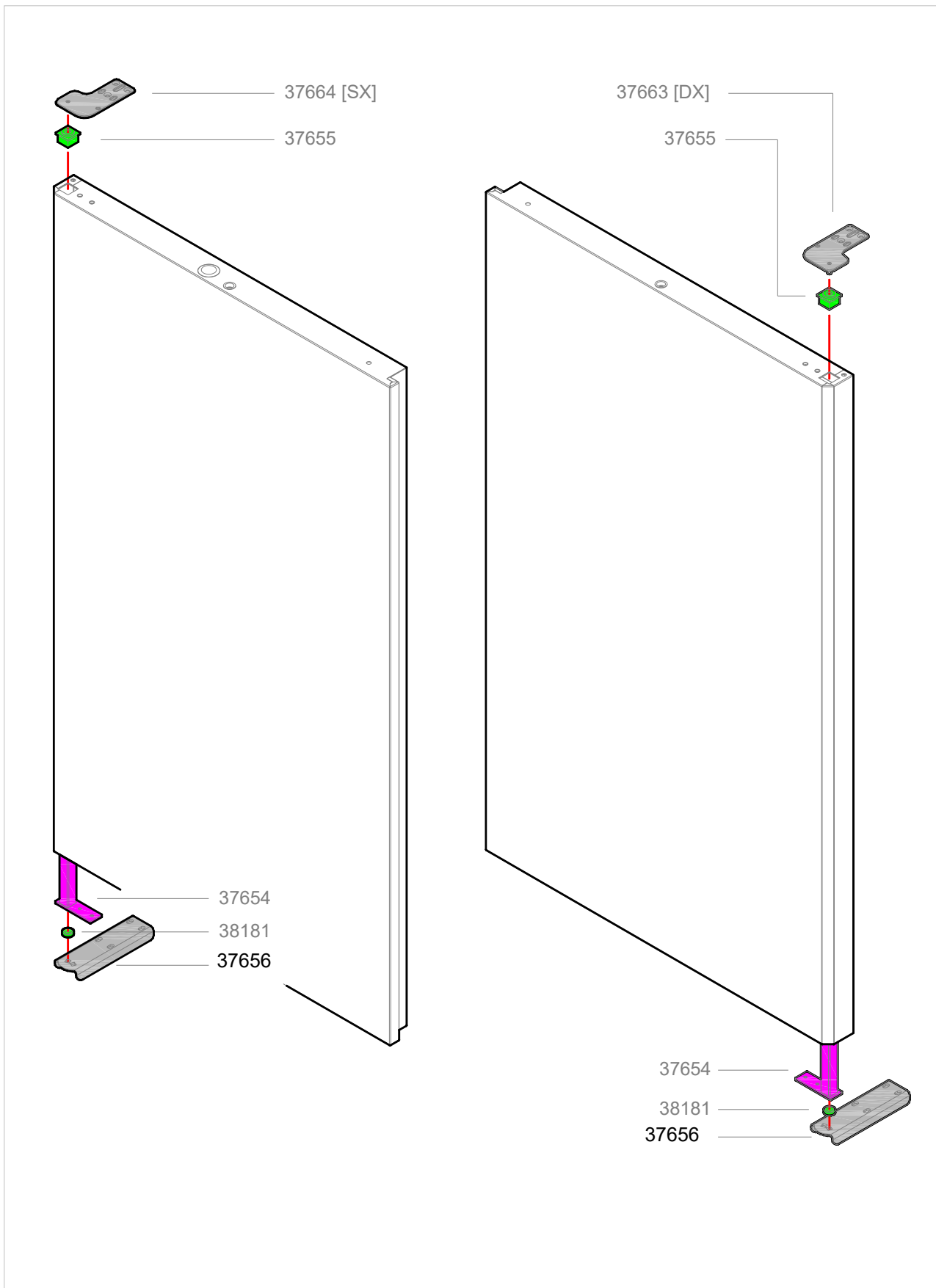

11. DISPOSAL OF THE APPLIANCE

 This appliance is marked in compliance with the 2002/96/EC European Directive, WASTE ELECTRICAL AND ELECTRONIC EQUIPMENT (WEEE).

 By assuring that this product is disposed of correctly, the user contributes to preventing the potential negative consequences on the environment and health.

The improper disposal of Waste Electrical and Electronic Equipment is liable to punishment under the relevant laws in the countries where the offence is committed.

11.1. Waste storage

At the end of the product life, avoid release to the environment.

Temporary storage of special waste is permitted while waiting for disposal by treatment and/or final collection. Dispose of special waste in accordance with the laws in force with regard to protection of the environment in the country of the user.

11.2. Equipment disassembly procedure



 Dismantling operations should be carried out by qualified personnel.

 If the equipment uses R290 cooling gas, every possible precaution must be taken to avoid any danger linked to the flammability of this gas.

 The doors should be removed before disposal.

 Make the appliance totally unusable by removing the power cable and any door locking

Waste electrical and Electronic Equipment may contain hazardous substances with potential harmful effects on the environment and human health. You are urged to dispose of them properly.

 The  symbol found on the product or on the accompanying documentation indicates that this product must not be treated as domestic waste but must be taken to suitable collection points for the recycling of electric and electronic appliances.

 For further information regarding the treatment, recovery and recycling of this product, contact the relevant local office, the domestic waste collection service or the shop where the product was purchased.

mechanisms in order to avoid the risk of anyone being trapped inside.

 If the equipment uses R452A, R134a refrigerant or other greenhouse gas (Fgas), it is mandatory to recover and dispose of the refrigerant as prescribed in the country of destination of the equipment.

 Dismantle the refrigerator grouping together the components according to their chemical nature. The compressor contains lubricating oil and refrigerant, which may be recycled. The refrigerator components are considered special waste, which can be assimilated with domestic waste.

12. TECHNICAL DATA SHEET OF REFRIGERANT R134a/R452A

Below is the chemical formula of the fluid **R134a**:

Name	Chemical Formula
HFC-134a	CH ₂ FCF ₃

Below are the components of fluid **R452A**:

Name	%	Chemical Formula
HFC-125	59%	C ₂ HF ₅
HFC-1234yf	30%	C ₃ H ₂ F ₄
HFC-32	11%	CH ₂ F ₂

IDENTIFICATION OF DANGERS

The rapid evaporation of the liquid can cause freezing. The inhalation of high concentrations of vapour can cause irregular heartbeat, short-term

narcotic effects (including vertigo, headache and mental confusion), fainting and death.

Effects on the eyes: Freezing or cold burns caused by contact with the liquid.

Effects on the skin: Freezing or cold burns caused by contact with the liquid.

Effects of ingestion the ingestion is not considered means of exposure.

FIRST AID

Eyes: In the case of contact, wash the eye well using a large amount of water for at least 15 minutes. Consult a doctor.

Effects on the skin: Wash with water for at least 15 minutes after excessive contact. If necessary, cure freezing by gently warming the area in question. Consult a doctor in the case of irritation.

Ingestion: Ingestion is not considered means of exposure.

Inhalation: If large concentrations are inhaled, go into the open air. Keep the person calm. If the person cannot breath, perform artificial respiration. If breathing is difficult, apply oxygen. Consult a doctor.

13. TECHNICAL DATA SHEET OF REFRIGERANT R290

Name	Chemical Formula
HC-290	CH ₃ CH ₂ CH ₃

IDENTIFICATION OF DANGERS

- Extremely flammable
- Liquefied gas



GHS02



GHS04

FIRST AID

Inhalation: The intervention of a doctor is recommended. At high concentrations, it can cause asphyxia. Symptoms may include loss of mobility and/or consciousness. Symptoms may include

dizziness, headache, nausea and loss of coordination.

Move the victim to an uncontaminated area wearing self-contained breathing apparatus. Keep the patient relaxed and warm. Perform artificial respiration if breathing stops.

Skin and eyes contact: Wash with water for at least 15 minutes. Remove contaminated clothes

Ingestion: No action is necessary. Ingestion is not considered a means of exposure.

FIRE PREVENTION MEASURES:

Suitable extinguishing media:

Water spray, Dry powder.

NON-Suitable extinguishing media:

DO NOT use water jets to extinguish.

Carbon dioxide (CO₂).



Recommendations:

DO NOT extinguish an inflamed gas leak unless absolutely necessary; an explosive re-ignition may occur.