

MOD : WIN2-14

Production code : NEWI14-75

Asian Cooking - Induction Wok Range

Induction - Wok Euro Line

NEWI 14-75 W2



Due to continuous technical development, the image shown may not represent the latest design of the unit.

DESCRIPTION

Induction wok with two glass-ceramic wok bowls Ø 300 mm. Powered by high-efficient, energy-saving induction coils of 5 kW each and a total connected load of 10 kW. Compact design with a depth of 750 mm. This wok is the perfect solution for cooking authentically Asian dishes where gas appliances are restricted.

The control unit with digital display and easy to use rotary knob to adjust the power (nine levels) or select the timer function (1 to 99 min), permits rapid heating and immediate operability. The impact-resistant wok bowl made of glass-ceramic with the stainless steel top surrounding is withstanding hard knocks in daily use.

The slanted, 3.2 mm strong reinforced top panel, the cold-water supply with two swivel faucets mounted on the backsplash together with the drainage channel in the back, guarantee maximum hygiene and enables an easy and time-saving cleaning of the top panel.

OTHER AVAILABLE MODELS

- NEWI 7-75

MAIN FEATURES

- Two impact-resistant glass-ceramic wok bowls Ø 300 mm.
- Two high-efficient, energy saving induction coils with 5 kW connected load each.
- Nine level power adjustment with rotary control knobs.
- LED display to indicate the operation modes and the selected power level or the remaining minutes when the timer function is activated.
- Slanted, reinforced top panel.
- Cold-water supply with two swivel faucets mounted on the backsplash.
- Drain channel with removable strainer in the back for easy operation and maximum hygiene.
- CE certified unit.

CONSTRUCTION

- Slanted, reinforced stainless steel top panel (3.2 mm), AISI 304 with orbital surface pattern.
- Front and back panels (0.8 mm), side panels (0.8 mm) made of stainless steel AISI 304 with hairline surface pattern.
- Backsplash made of stainless steel AISI 304 with hairline surface pattern (1.2 mm).
- Tubular, height adjustable (± 10 mm) stainless steel legs.
- Types of installations: free standing.
- Frame, top and panels, all made of high-grade stainless steel.

INCLUDED ACCESSORIES

- Wok pan Ø 400 mm, stainless steel AISI 409 (2 pcs)

OPTIONAL ACCESSORIES

- Power cable type: H07RN-F (5 x 4 mm²).

FRONT

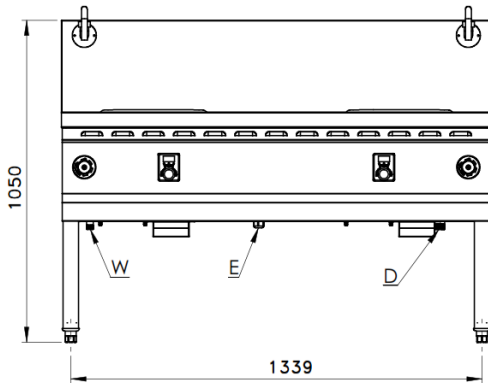

TOP

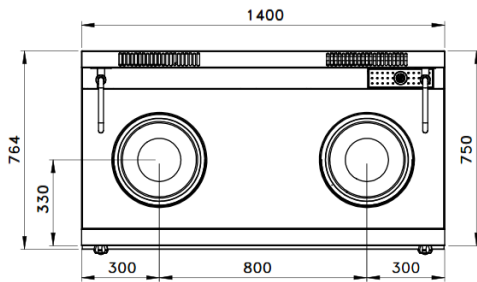

SIDE

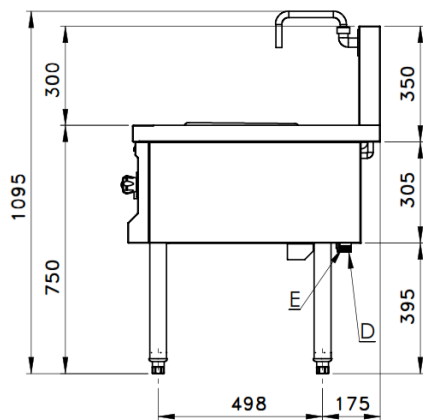

TECHNICAL DATA

External Dimensions

Width : 1400 mm
 Depth : 750 mm
 Height : 750/1050 mm

Cooking Surface

Wok hobs : 2 x Ø 300 mm
 Heating zones : 2 x 5 kW
 Control type : Modulating power control

Electrical Supply Data

Total connected load : 10 kW
 Voltage : 380V, 2PNE AC /50-60Hz
 Recommended fuse : 25 A (slow)

Connections

Water : DN15 (1/2")
 Drain : DN25 (1")

Heat & Steam Emissions

Direct heat emission : 0.70 kW
 Latent heat emission : 0.28 kW
 Steam emission : 0.41 kg/h

PACKAGING DATA

Width : 1430 mm
 Depth : 780 mm
 Height : 1170 mm
 Volume : 1.31 m³

WEIGHT

Net Weight : 79 kg
 Gross Weight : 110 kg

*Overall dimension in mm