

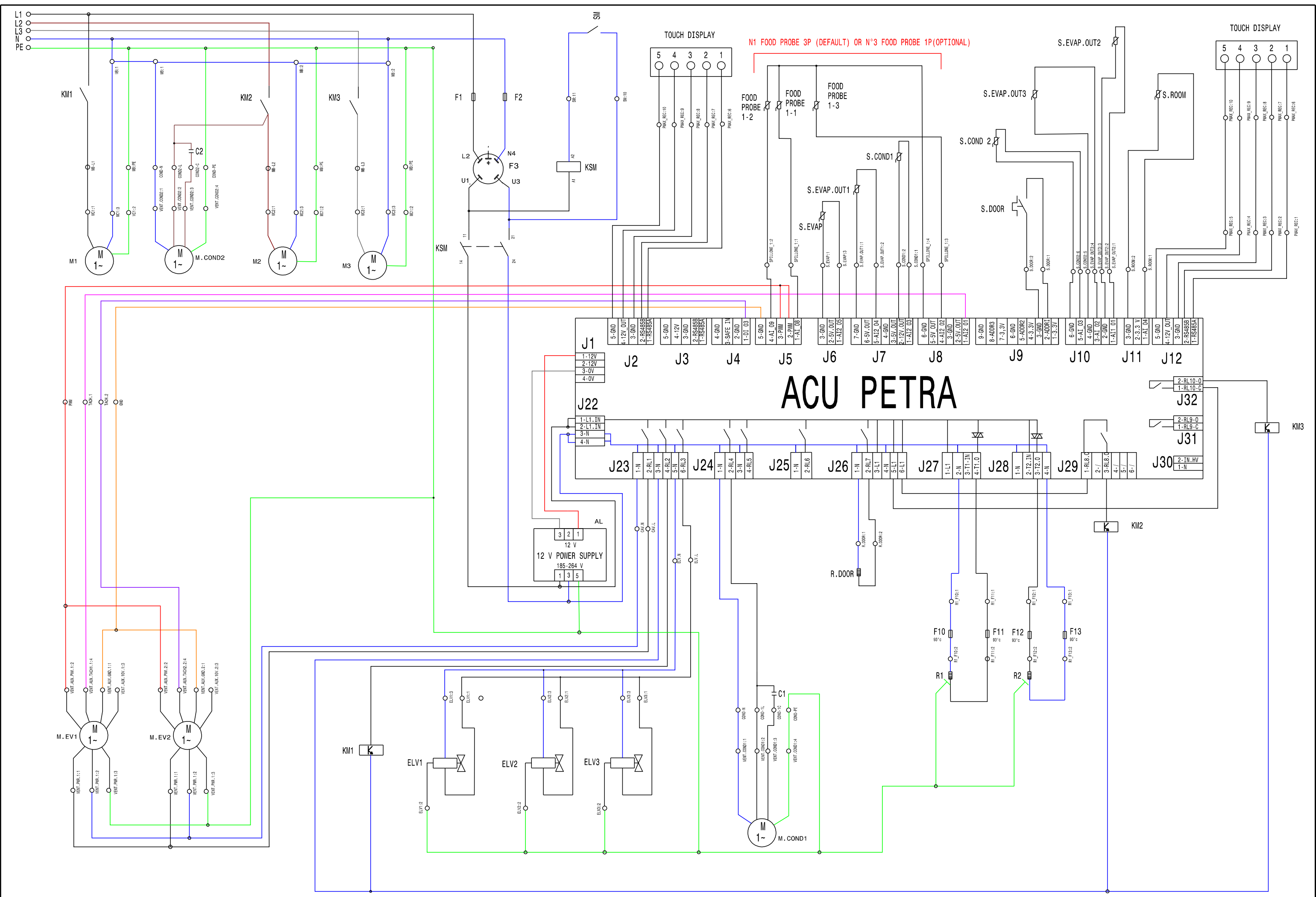

MOD : BCC/XT-10-R2

Production code : 729736

08/2025



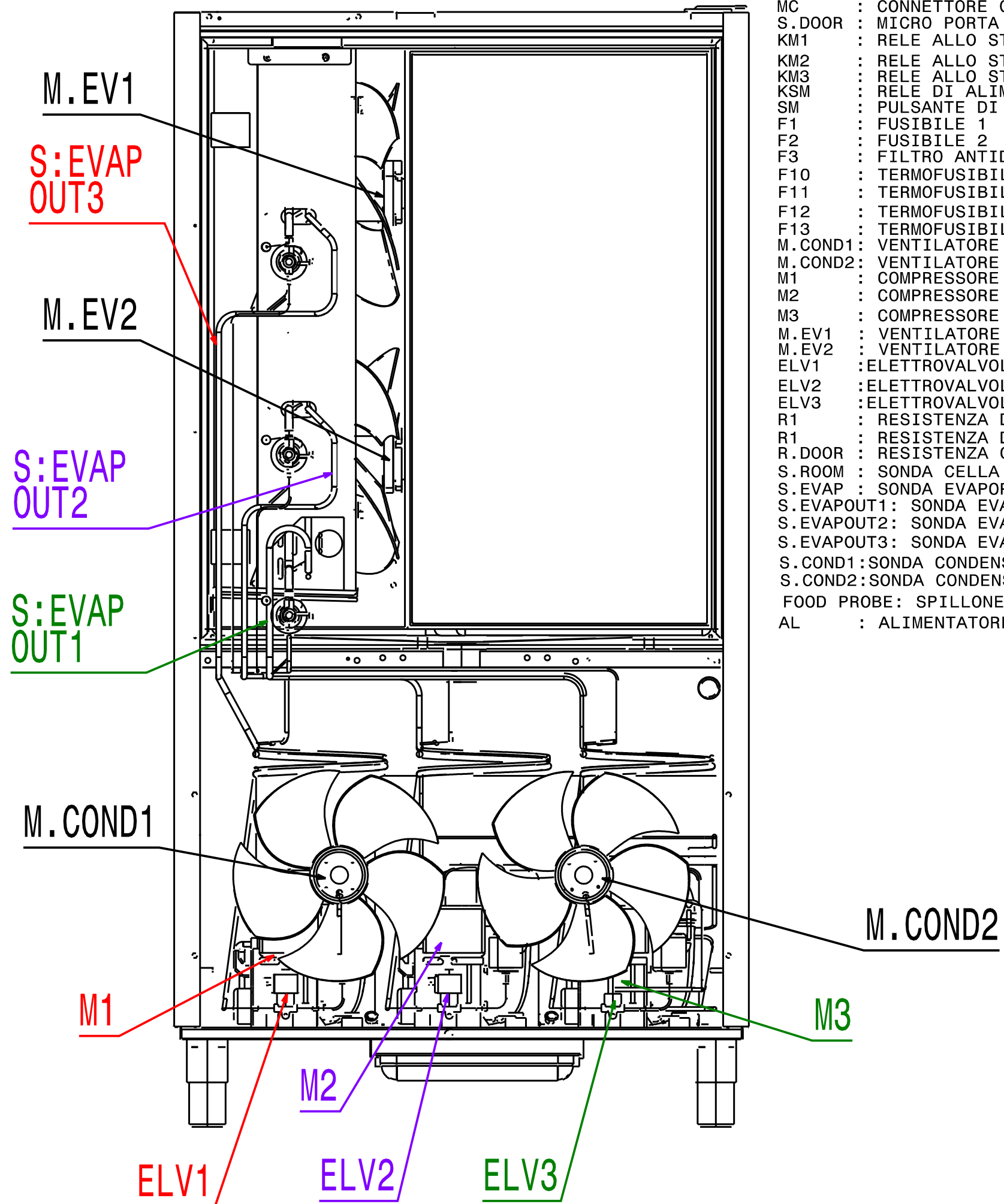

REAR VIEW

LEGENDA

- MB : MORSETTIERA CARICHI
- MC : CONNETTORE COMPRESSORE
- S.DOOR : MICRO PORTA
- KM1 : RELE ALLO STATO SOLIDO 1
- KM2 : RELE ALLO STATO SOLIDO 2
- KM3 : RELE ALLO STATO SOLIDO 3
- KSM : RELE DI ALIMENTAZIONE
- SM : PULSANTE DI ACCENSIONE
- F1 : FUSIBILE 1
- F2 : FUSIBILE 2
- F3 : FILTRO ANTIDISTURBO
- F10 : TERMOFUSIBILI 1
- F11 : TERMOFUSIBILI 2
- F12 : TERMOFUSIBILI 3
- F13 : TERMOFUSIBILI 4
- M.COND1: VENTILATORE CONDENSATORE 1
- M.COND2: VENTILATORE CONDENSATORE 2
- M1 : COMPRESSORE 1
- M2 : COMPRESSORE 2
- M3 : COMPRESSORE 3
- M.EV1 : VENTILATORE CELLA 1
- M.EV2 : VENTILATORE CELLA 2
- ELV1 :ELETTOVALVOLA 1
- ELV2 :ELETTOVALVOLA 2
- ELV3 :ELETTOVALVOLA 3
- R1 : RESISTENZA DI SBRINAME/RISCALDAME 1
- R2 : RESISTENZA DI SBRINAME/RISCALDAME 2
- R.DOOR : RESISTENZA CORNICE
- S.ROOM : SONDA CELLA
- S.EVAP : SONDA EVAPORATORE
- S.EVAPOUT1: SONDA EVAPORATORE IN USCITA 1
- S.EVAPOUT2: SONDA EVAPORATORE IN USCITA 2
- S.EVAPOUT3: SONDA EVAPORATORE IN USCITA 3
- S.COND1:SONDA CONDENSATORE 1
- S.COND2:SONDA CONDENSATORE 2
- FOOD PROBE: SPILLONE
- AL : ALIMENTATORE 12 V

LEGEND

- MB : TERMINAL BOARD FOR POWER LOADS
- MC : COMPRESSOR CONNECTOR
- S.DOOR : DOOR MICROSWITCH
- KM1 : SOLID STATE RELAY 1
- KM2 : SOLID STATE RELAY 2
- KM3 : SOLID STATE RELAY 3
- KSM : POWER SUPPLY RELAIS
- SM : POWER SUPPLY PUSH-BUTTON
- F1 : POWER FUSE 1
- F2 : POWER FUSE 2
- F3 : RADIO INTERFERENCE SUPPRESSOR
- F10 : TERMOFUSE 1
- F11 : TERMOFUSE 2
- F12 : TERMOFUSE 3
- F13 : TERMOFUSE 4
- M.COND1: CONDENSER FAN 1
- M.COND2: CONDENSER FAN 2
- M1 : COMPRESSOR 1
- M2 : COMPRESSOR 2
- M3 : COMPRESSOR 3
- M.EV1 : EVAPORATOR FAN 1
- M.EV2 : EVAPORATOR FAN 2
- ELV1 : ELECTROVALVE 1
- ELV2 : ELECTROVALVE 2
- ELV3 : ELECTROVALVE 3
- R1 : HEATING/DEFROST ELEMENT 1
- R2 : HEATING/DEFROST ELEMENT 2
- R.DOOR : DOOR HEATER
- S.ROOM : COMPARTMENT PROBE
- S.EVAP : EVAPORATOR PROBE
- S.EVAPOUT1:OUT EVAPORATOR PROBE 1
- S.EVAPOUT2:OUT EVAPORATOR PROBE 2
- S.EVAPOUT3:OUT EVAPORATOR PROBE 3
- S.COND1:CONDENSER PROBE 1
- S.COND2:CONDENSER PROBE 2
- FOOD PROBE: FOOD PROBE
- AL : POWER SUPPLY 12 V