

MOD : WR-RVGS-G3

Production code : MN3G_

USER'S MANUAL

WR-RVGS-G3



INDEX

Chapter 1.... General description
Chapter 2.... Apparatus' use
Chapter 3..... Loading and cleaning the oven
Chapter 4.... Technical instructions for installation and adjustment
Chapter 5.... Spare parts assembly
Appendix A.. List of spare parts
Appendix A.1.. Electric diagrams P. 36
Appendix B...Technical data. Gas categories and pressures P. 37

CHAPTER 1

GENERAL DESCRIPTION

INDICATIONS

This apparatus should be installed in compliance with legislation in force and should be used in well ventilated areas only. Read the instructions prior to installation and use. For correct combustion the place where the grill is installed must have at least a minimum ventilation 10m³ / h of air per kW of heat input in operation. Consult instructions before installation and use.

When installing the oven, you should follow the instructions and requirements of the gas supplier and, in any case, contract an authorised technician to install it.

The apparatuses described below are for collective use and should only be handled by suitably qualified personnel. This apparatus is model A: without fan.

DESCRIPTION OF THE APPARATUS

All vertical models are made in stainless steel except the components that are used to handle

Basically, the following elements are present in the various model comprising the range of vertical ovens

- a) Structure
- b) Transmission
- c) Electric controls panel
- d) Gas equipment
- e) Doors
- f) Accessories

STRUCTURE

The dimensions of the part meant to support the various elements of the oven will depend on the number of spits in the oven and on whether or not it is to be assembled on a base.

TRANSMISSION

The transmission of the apparatus is being chain which will make all the spits turn synchronically. Transmission is moved by a motor reducer whose turnover speed is 4.5 r.p.m.

ELECTRIC EQUIPMENT

This comprises the motor described in the previous section and a luminous control switch situated at the bottom left of the apparatus.

WARNING: The oven is connected to the mains at 230V for the gas models.

GAS EQUIPMENT

This consists of as many infrared burners, with their corresponding safety valves and thermocouples situated one above the other and separated by an inter-burner sheet, as there are spits in the specific oven model.

It is all fed through a battery with a feed input of ½" gas.

DOORS

The doors consist of two panes of tempered glass with insulated handles. The glass panels are assembled on the front of the oven. Their purpose is to protect you from the heat while the oven is in operation and to protect the food from external agents.

WARNING: Try not to hit the glass as they could break either at that moment or else later without any apparent reason for their doing so.

Do not leave any burner on when the doors are closed unless there is food roasting on the spit in question, the glass can explode.

Keep the glass clean and check that it is dry before each operation.

ACCESSORIES

The oven is equipped with a series of accessories such as the spits, skewers, hook for removing the spits and tray.

a) Spits

Their purpose is to fix, through the skewers, the food to be roasted. Their cross-section is square so that they will rotate when placed in the drag axles. The spits are equipped with insulated handles to avoid burns. The number of spits depends on the oven model. Maximum 4.5kg per spit. Always Respect Maximum Spit Load. Non Respect can damage the motor.

b) Skewers

Your rotisserie is provided with 2 simple skewers with screw (end) and 2 double skewers (center). These skewers are necessary for 3 chickens.

c) Tray

The tray is situated inside the roasting chamber beneath the spits with the purpose of collecting all the juices from the roast. It is not necessary to put water on it.

WARNING: IT IS COMPULSORY WEARING GLOVES WHEN HANDLING THE SPIT OR THE ROASTER TRAY

CHAPTER 2

APPARATUS' USE

LIGHTING THE BURNERS

The oven should be connected to a main plug with an earth and neutral connection. The type and pressure of the gas should correspond to what is indicated on the characteristics plate.

Once this has been checked, proceed as follows:

- a) Open the general gas tap
- b) Open the doors.
- c) Press in the control of the required burner and make a quarter turn anti-clockwise until the "maximum" position is reached (**Fig. 3**).
- d) Without releasing, approach the burner with an open flame until it lights up. Wait 10 to 15 seconds before releasing; the burner should remain alight.
- e) To set the control to "minimum", turn the control anticlockwise from the "maximum" position until reaching the "minimum" one, without pressing (**Fig. 3**).
- f) To switch the burner off, turn the control from any position in a clockwise direction to the "off" indicator.
- g) Do not leave any burner on when the doors are closed unless there is food roasting on the spit in question, the glass can explode.

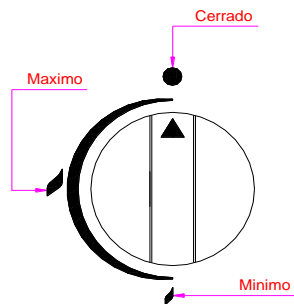

Fig. 3

ORDER FOR LIGHTING

Always start at the top of the oven downwards until you reach the bottom layer.

WARNING: You should never leave a burner on for roasting when the one below it is off. Close the regulators and taps when the oven is not in use.

ROTATION OF THE SPITS

When you press the switch at the bottom left of your oven, this will light up and the spits will start to turn. Upon pressing it again, the pilot lamp will go out and the spits will stop turning

CHAPTER 3

LOADING AND CLEANING THE OVEN

LOADING THE OVEN

- a) Put the simple skewer (1) in the spit (3) until it reaches the safety limit of the spit. Then fix it with the screw (2). (See fig. 5).
- b) Then place a chicken on the spit and hold it in place with the skewer already in position. Put the double skewer (4) on the spit and in a chicken. Repeat this operation until the spit is fully loaded and finally put a simple skewer in place and fix it with its screw.
- c) The maximum weight per sword is 4.5 Kg.

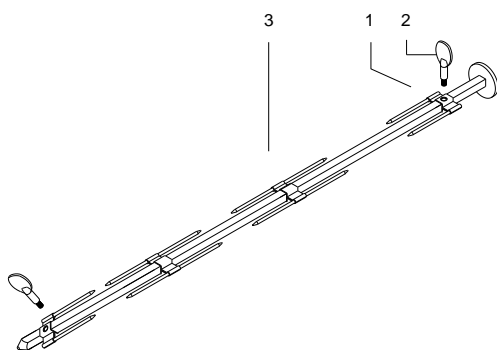

Fig. 5

CLEANING

You can use any product on the market for cleaning your oven. Take care not to spill any cleaning liquid on the perforated surface of the burner. Do not use abrasive products as they could damage the surfaces of stainless steel. The quality of your roasts depends on the cleanliness of your oven.

It is recommended to clean the floor daily to avoid slipping and the work areas as well as the grease tray, the cooking area, the sides, the glass and the upper part of the grill to avoid the accumulation of grease and the risk of fire.

CLEANING THE INTER-BURNER SHEET

This sheet, situated between the burners, can be removed to facilitate cleaning. To do this, proceed as follows: (**fig. 6**).

- a) Pull the bottom of the sheet towards you until it is horizontal.
- b) Lift it until you notice that the sheet has reached a limit.
- c) Then pull it outwards and the sheet will have been extracted from the oven.

To replace it, proceed as follows:

- a) Enter the sheet horizontally so that its side grooves coincide with the pivots on each side.
- b) Let the sheet swing downwards.

NOTE: It is advisable to have your oven inspected regularly by an authorised technician. By doing so, you will be sure that your oven is always in perfect working condition.

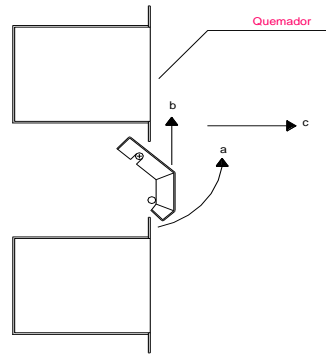

Fig. 6

CHANGE OF GAS TYPE

It is advisable to call a qualified installer to install the device, and if necessary, to adapt it to use another type of gas.

In case of fire, close the gas supply tap of the installation and the appliance, and turn off with CO₂ extinguishers, which must be available in your premises.

CHAPTER 4

THECNICAL INSTRUCTIONS FOR INSTALLATION AND ADJUSTMENT

INSTALLATION

These operations can only be carried out by a certified technician.

The appliance must be placed on a flat, stable surface. This device must be installed in accordance with the regulations in force, and should be used only in well-ventilated areas. For correct combustion the place where the grill is installed must have at least a minimum ventilation 10m³ / h of air per kW of heat input in operation

SPACE

To be installed correctly, the oven requires a space at least equal to its own dimensions plus the necessary distance from a wall or any other apparatus as described in **Fig. 2**. The minimum distance to be observed from any point of the device to any combustible material must be 2 meters. However, the installation of a smoke extractor bell is recommended to prevent any damage to the ceiling of the premises in which it is installed as well as any deterioration caused by the heat, smoke and fats expelled during operation.

Roasters up to 4 broches must be installed above one of our in order to have the best ventilation. Otherwise, they must be installed at least at 10cm from the floor.

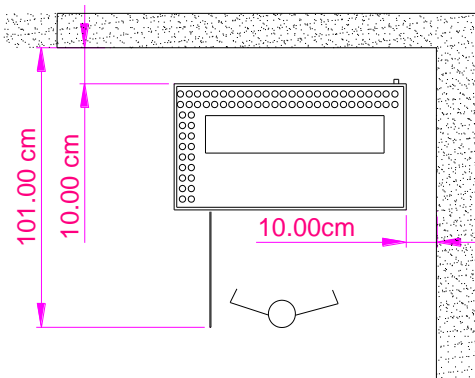

Fig. 2

WARNING: Check the measures indicated in Chapter 5, section "Technical Data", prior to setting up or installing the oven". It is advised that these conditions must be respected to avoid the occurrence of unacceptable concentrations of substances harmful to health in the room where they are installed.

WARNING:

Before operating the oven, make sure that the voltage as well as the pressure and type of gas coincide with the indications on the characteristics plate situated bottom left on the front of the apparatus.

Do not place any object on top of the oven or along its sides that could obstruct the ventilation grilles.

CONNECT THE OVEN

At the bottom right at the back of the oven you will find a 1/2" gas connector for ovens using Butane/Propane gas. Next to the gas inlet is the cable for connecting to the electricity mains.

The hose gas supply must meet the regulations in force and it should be checked periodically and replaced when necessary. The maximum length will be 2 meters.

WARNING:

Make sure that the voltage of the mains supply corresponds to that indicated on the characteristics plate and that it has an appropriate earth connection.

CHANGING THE GAS

WARNING: This operation can only be done by an authorised technician

- Make sure that the gas supply to the oven is closed.
- Change the apparatus inlet pipe. This should only be done in the case of changing from Butane or Propane to Natural Gas. In this case, the interior diameter of the pipe should **never be less than 1,8mm**.
- Remove all the controls (3) (See fig. 7) of the valves by pulling them outwards.
- Then remove all the screws fastening the controls panel.
- Remove all the nuts (11) and remove the tube (12)
- Pull the elbow piece outwards (8) and the set formed by parts (5), (6) and (7) will come out of the burner.
- Unscrew the elbow piece (8) from said set and replace the injector (6) with the one suited for the type of gas to be used. The diameter of the injector is indicated on its casing. Do not forget to replace the washer of the joint (7) with a new one.
- Proceed in reverse order to that described in points e) to g) to reassemble.
- Repeat this operation for each burner in your oven.
- Once you have done this **MAKE SURE** that there are no gas leaks and replace the controls panel.

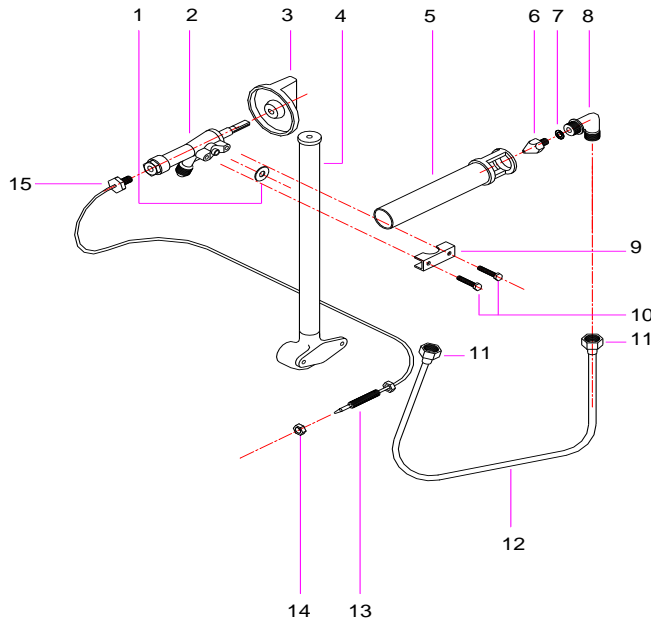

Fig. 7

! reading "Apparatus"

MINIMUM BURNER ADJUSTMENT

- Remove the control of the valve of the burner you wish to adjust.
- Put a screwdriver through the hole in the control panel and loosen the screw (1) **Fig. 8** in a clockwise direction to reduce the minimum or anticlockwise to increase the minimum.
- Replace the control once the minimum has been adjusted

TAUTENING THE CHAIN

- Remove totally the screws fastening the transmission cover and remove it
- Loosen slightly screw (1) fig. 9 and move the tautener to the left. Fasten the tautener again by tightening the screw (1) once the chain is properly tautened.

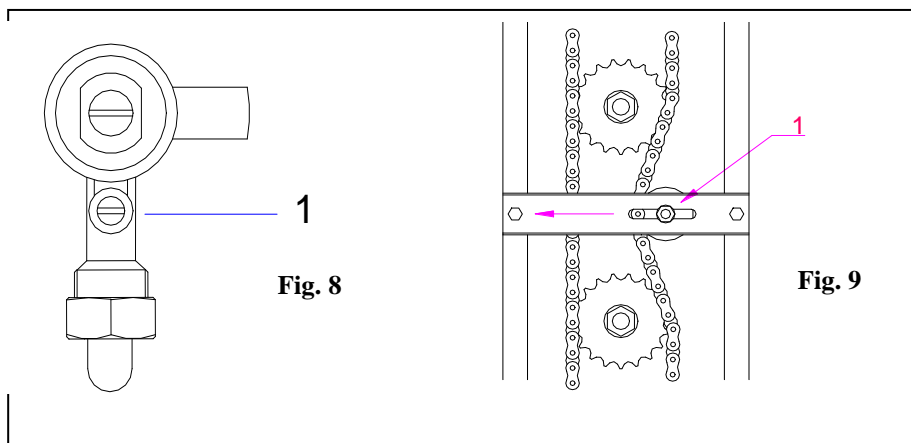

ASSEMBLY OF SPARE PARTS

WARNING: These operations can only be done by an authorised technician

Once a year, a revision of the device must be carried out, taking into account the cleaning of the injectors and the gas outlet valves.

CHANGING THE MOTOR REDUCER

- Remove the Disconnect the oven from the mains. Remove the cover of the transmission on the left side of the oven by loosening the screws fastening it.
- Loosen the screws (4) Fig. 10 to remove the chain that joins the pinion (3) and the axle of the first spit.
- Once the chain has been removed, totally remove the screws (4) to take out the motor support (5) along with the motor reducer.
- Loosen the screw fastening the pinion (3) to the axle of the motor reducer to remove it from the axle. Totally screws (2) to dismount the motor reducer from the support.
- Change the motor reducer and proceed in reverse order to what is explained above to assemble it.

WARNING When correctly tautened the motor chain should have a flexion in the centre of about 1 cm. An excessively taut chain produces unnecessary work stress on the motor reducer.

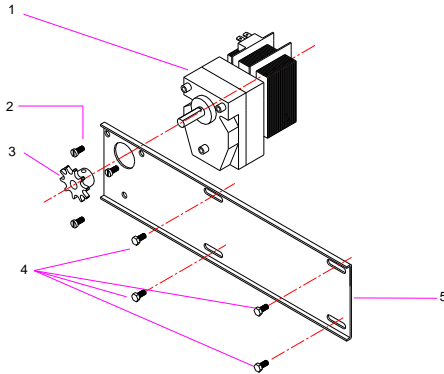

Fig. 10

CHANGING A VALVE

- Disconnect the oven from the mains and close the gas supply. **Make sure the gas supply is closed before you continue with this operation.**
- Remove all the valve controls (on the right of the oven) by pulling them outwards.
- Remove totally the screws fastening the controls panel and remove it
- Loosen the tube (12) (See Fig. 7) by loosening the nuts (11) of the valve you wish to change. Then dismount the thermocouple of the valve by loosening the nut (15).
- Totally loosen the screws (10) which, together with the bracket (9), fasten the valve to the battery.
- Proceed in reverse order to what is explained above to assemble the new valve. Do not forget to replace the washer of the joint (1) with a new one.
- Make sure there are no gas leaks. Then adjust the minimum of the burner and finally replace the controls panel.

CHANGING A THERMOCUPLE

- Disconnect the oven from the mains and close the gas supply. **Make sure that the gas supply is closed before you continue with this operation.**
- Remove all the valve controls (on the right of the oven) by pulling them outwards.
- Loosen totally the screws fastening the controls panel and remove it.
- Loosen the nuts (15) and (9) (See Fig. 7) of the thermocouple you wish to change and remove it.
- Assemble the new thermocouple by proceeding in reverse order to what is explained above. Then replace the controls panel and controls.

CHANGING A BURNER

- Disconnect the oven from the mains and close the gas supply. **Make sure that the gas supply is closed before you continue with this operation.**
- Remove all the valve controls (on the right of the oven) by pulling them outwards. Then remove the top and bottom inter-burner sheets of the burner you wish to change.
- Remove totally the screws fastening the controls panel and remove it
- Remove totally the screws fastening the rear panel and pull it towards the left to remove it
- Remove the tube (12) and thermocouple (13) (See Fig. 11) corresponding to the valve of the burner you wish to change by loosening the nuts (11) and (14).
- Pull the elbow piece (8) outwards to remove the Venturi burner. Totally loosen the screws fastening the burner (16) to its support (17).
- Replace the burner and assemble the new one in its support.
- Proceed in reverse order to what is explained above to assemble it. **MAKE SURE** there are no gas leaks. Replace the panels and do not forget to adjust the minimum of the burner.

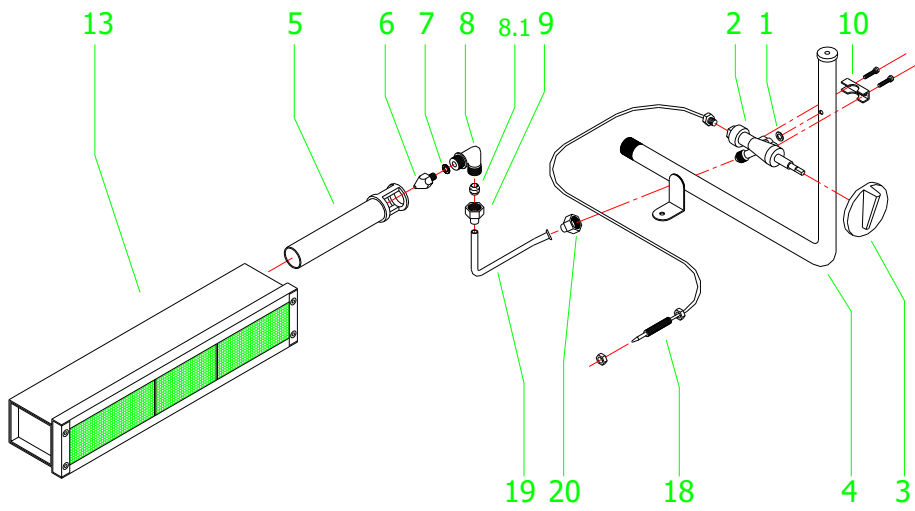

Fig 11

APPENDIX A

List of spare parts that may require changing. Electric diagram.

Denomination	Code
Burner	193001
Safety valve	030112
Thermocouple	030115
Butane/Propane injector	23009
Natural Gas injector	4400012
Motor reducer 220V	020112
Simple switch	060004
Simple Skewer (without screw)	050107
Double Skewer	050110
Skewer screw	050116
Oven glass, model. WR-RVGS-G2	194201
Oven glass, model. WR-RVGS-G3	194301
Oven glass, model. WR-RVGS-G4	194401

APPENDIX B

**GAS TYPES AND PRESSURES
GASKATEGORIE UND GASDRUCK
CATEGORIES ET PRESSIONS GAZ
CATEGORIAS Y PRESIONES DE GAS
GASTYPES EN GASDRUK**

AT	20 - 50	II2H3B/P
BE, FR	20/25 - 28/37	II2E+3+
DE, LU	20 - 50	II2E3B/P
DK	20 - 30	II2H3B/P
ES, GB, GR, IE, CH	20 - 28/37	II2H3+
EE, FI, LT, LV, NO, RO, SI, BG, SE, HR, TR	20 - 30	II2H3B/P
IT, CZ, PT, SK	20 - 30/37	II2H3+
NL	20 - 30/37	II2EK3B/P
HU	25 - 30	II2HS3B/P
PL	20 - 37	II2E3B/P
MT, CY	30	II3B/P

**DATOS TÉCNICOS ASADORES A GAS
TECHNISCHE INFORMATIE – GASOVENS**

MODEL	Leng.x DeptxHeig.	Weight	GAS	PRESSURE	FLOW	FLOW	POWER Hi
MODELO	Larg.x Anch.x Alt.	Peso	GAS	PRESION	CONSUMO	CONSUMO	POTENCIA Hi
MODELE	Larg. xProf. x Haut	Poids	GAZ	PRESSION	CONSUPTION	CONSUPTION	PUISSANCE Hi
MODELL	Läng.x Breit.x Höh.	Gewicht	GASTYPE	DRUCK	VERBRAUCH	VERBRAUCH	LEISTUNG Hi
MODEL	Lengte x Bre. x Hoo.			DRUK	VERBRUIK	VERBRUIK	VERMOGEN HI
WR-RVGS-G2	800 x 400 x 555	40 Kg	G30	30	568 g/h	5,85 Kw	6,4 Kw
			G30	50	710 g/h	7,5 Kw	9 Kw
			G20	20	0,76 m3/h	5,1 Kw	7,2 Kw
			G20	25	0,84 m3/h	5,65 Kw	8 Kw
			G25.3	25	0,87 m3/h	4,85 Kw	7,2 Kw
WR-RVGS-G3	800 x 400 x 735	50 Kg	G30	30	852 g/h	8,78 Kw	9,6 Kw
			G30	50	1065 g/h	11,25 Kw	13,5 Kw
			G20	20	1,14 m3/h	7,65 Kw	10,8 Kw
			G20	25	1,26 m3/h	8,48 Kw	12 Kw
			G25.3	25	1,31 m3/h	7,28 Kw	10,8 Kw
WR-RVGS-G4	800 x 400 x 915	63,5 Kg	G30	30	1136 g/h	11,7 Kw	12,8 Kw
			G30	50	1420 g/h	15 Kw	18 Kw
			G20	20	1,52 m3/h	10,2 Kw	14,4 Kw
			G20	25	1,69 m3/h	11,3 Kw	16 Kw
			G25.3	25	1,73 m3/h	9,7 Kw	14,4 Kw

Gas	Druk	Diameter
G30	28/30/50 mba	0.90
G31	30/37/50 mbar	0.90
G20	18/20/25 mbar	1.50

BURNER INJECTORS - Note: The diameter of the injectors is indicated on their casing (mm)
INJECTORES DE QUEMADOR - Nota: El diámetro de los inyectores va marcado en los mismos (mm)
CHICLEURS DU BRULEUR - Nota: Le diamètre des injecteurs est inscrit sur les injecteurs mêmes (mm)
DÜSEN DER BRENNER - Anmerkung: Der Durchmesser der Düsen ist an denselben gekennzeichnet (mm)
INJECTOREN VAN DE BRANDERS - Opmerking: De diameter van de injectoren staat op de injectoren zelf (mm)