

MOD : WR-RVEL-E3

Production code : MN3E

USER'S MANUAL

WR-RVEL-E3



INDEX ENGLISH

Chapter 1....	DESCRIPTION OF THE APPARATUS
Chapter 2....	INSTALLATION
Chapter 3...	DESCRIPTION OF THE CONTROLS
Chapter 4....	LOADING AND CLEANING THE OVEN
Chapter 5....	TECHNICAL INSTRUCTIONS FOR INSTALLATION AND ADJUSTMENT
Chapter 6....	ASSEMBLY OF THE SPARE PARTS
Appendix A...	LIST OF SPARE PARTS
Appendix B...	ELECTRIC DIAGRAMS (p. 24)

CHAPTER 1

DESCRIPTION OF THE APPARATUS

INDICATIONS

This apparatus should be installed in compliance with legislation in force and should be used in well ventilated areas only. Read the instructions prior to installation and use.

When installing the oven, you should, in any case, contract an authorised technician to install it.

The apparatuses described below are for collective use and should only be handled by suitably qualified personnel.

DESCRIPTION OF THE APPARATUS

Basically, the following elements are present in the various models comprising the range of MINI ovens

- Structure, optionally with support
- Transmission
- Electric controls panel
- Gas equipment
- Doors
- Accessories

STRUCTURE

The dimensions of the part meant to support the various elements of the oven will depend on the number of spits in the oven and on whether or not it is to be assembled on a base.

TRANSMISSION

The transmission of the apparatus is by chain which will make all the spits turn synchronically. Transmission is moved by a motor reducer whose turnover speed is 4.5 r.p.m.

ELECTRIC EQUIPMENT

This comprises the motor described in the previous section and a luminous control switch situated at the bottom left of the apparatus. In the electric models, in addition to what is described above, also two electric elements of 1100W each (2200W per spit).

WARNING: The oven is connected to the mains at 400V + N + E for the electric models

DOORS

The doors consist of two panes of tempered glass with insulated handles. The glass panels are assembled on the front of the oven. Their purpose is to protect you from the heat while the oven is in operation and to protect the food from external agents.

WARNING: Try not to hit the glass as they could break either at that moment or else later without any apparent reason for their doing so. Do not leave any burner on when the doors are closed unless there is food roasting on the spit in question. Keep the glass clean and check that it is dry before each operation.

ACCESSORIES

The oven is equipped with a series of accessories such as the spits, skewers, hook for removing the spits and tray.

a) Spits

Their purpose is to fix, through the skewers, the food to be roasted. Their cross-section is square so that they will rotate when placed in the drag axles. The spits are equipped with insulated handles to avoid burns. The number of spits depends on the oven model. Maximum 4.5kg per spit. Always Respect Maximum Spit Load. Non Respect can damage the motor.

b) Skewers

Your rotisserie is provided with 2 simple skewers with screw (end) and 2 double skewers (center). These skewers are necessary for 3 chickens.

c) Tray

The tray is situated inside the roasting chamber beneath the spits with the purpose of collecting all the juices from the roast. It is not necessary to put water on it.

WARNING: IT IS COMPLUSARY WEARING GLOVES WHEN HANDLING THE SPIT OR THE ROASTER TRAY

CHAPTER 2

INSTALLATION

SPACE

To be installed correctly, the oven requires a space at least equal to its own dimensions plus the necessary distance from a wall or any other apparatus as described in **Fig. 2**. The installation should be made in compliance with the safety standards in force in your area. The oven is a Type A appliance meaning that forced extraction of the combustion gases is not required. However, the installation of a smoke extractor bell is recommended to prevent any damage to the ceiling of the premises in which it is installed as well as any deterioration caused by the heat, smoke and fats expelled during operation.

WARNING: Check the measures indicated in Chapter 5, section "Technical Data", prior to setting up or installing the oven"

WARNING: Make sure the installation voltage is the same as the one indicated on the characteristics plaque placed at the frontal bottom left hand corner of the roaster.

Do not place any object on top of the oven or along its sides that could obstruct the ventilation grilles.

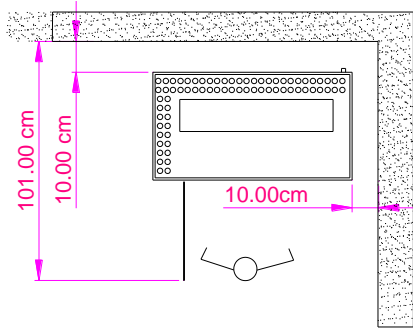

Fig. 2

CHAPTER 3

DESCRIPTION OF THE CONTROLS

The electric rotisseries must be connected to an electrical outlet with their corresponding protective magnetothermal. The electric rotisseries are supplied without the connection cable and it must be sized according to the power of your rotisserie and the current regulations

LIGHTING THE ELEMENTS

Once you have made sure that the mains connection corresponds to what is indicated on the characteristics plate, merely make a quarter in any direction of the control (Fig. 4) of the element to be used to switch on.

To switch the elements off, make a quarter turn of the control of each element.

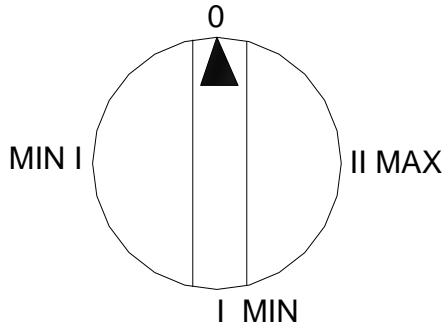

Fig. 4

ROTATION OF THE SPITS

When you press the switch at the bottom left of your oven, this will light up and the spits will start to turn. Upon pressing it again, the pilot lamp will go out and the spits will stop turning.

CHAPTER 4

LOADING AND CLEANING THE OVEN

LOADING THE OVEN

- a) Put the simple skewer (1) in the spit (3) until it reaches the safety limit of the spit. Then fix it with the screw (2). (See fig. 5).
- b) Then place a chicken on the spit and hold it in place with the skewer already in position. Put the double skewer (4) on the spit and in a chicken. Repeat this operation until the spit is fully loaded and finally put a simple skewer in place and fix it with its screw.

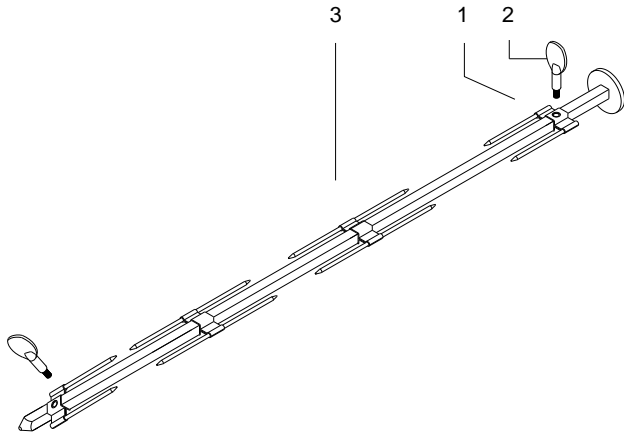
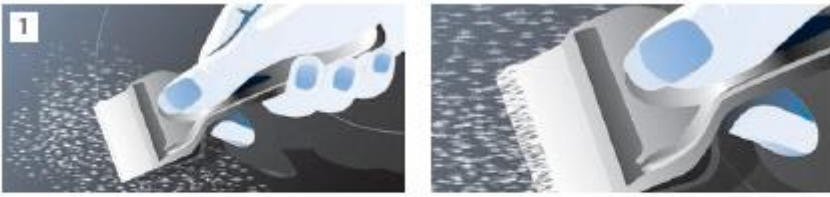

Fig. 5

VITROCERAMIC GLASS CLEANING

Sparkling results in only three steps:



To thoroughly clean your glass ceramic cooktop, first remove dirt and food with a suitable metal scraper or special sponge for glass ceramic cooktops.

NOTE: It is advisable to have your oven will be inspected regularly by an authorised technician. Doing so, you will be sure that your oven is always on a perfect working condition.

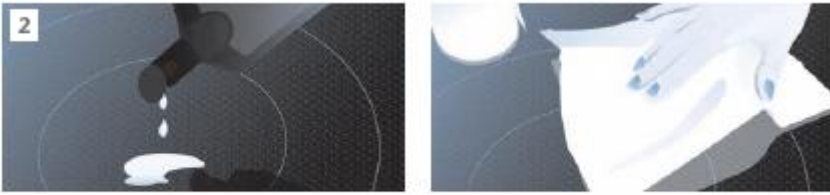

Once the glass ceramic cooktop has cooled, put a few drops of a suitable cleaner on it and rub it on with a paper towel, a clean cloth or an approved cleaning sponge.

CHAPTER 5

TECHNICAL INSTRUCTIONS FOR INSTALLATION AND ADJUSTMENT

WARNING: These operations can only be done by an authorised technician

Conection:

In the lower right side of the rear face of the rotisserie are the connection terminals. Secure the cable with the flange.

Check that the rotisserie plug is of the voltage indicated on the nameplate and has a suitable earth.

Tautening the chain

- a) Remove totally the screws fastening the transmission cover and remove it.
- b) Loosen slightly screw (1) fig. 9 and move the tautener to the left. Fasten the tautener again by tightening the screw (1) once the chain is properly tautened.

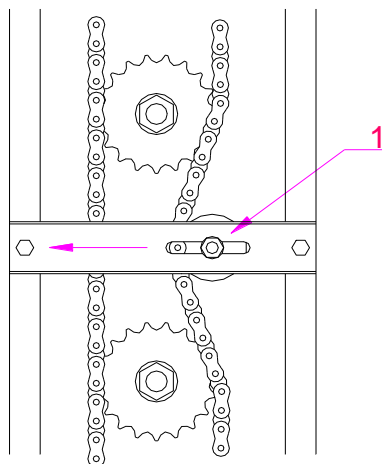

Fig. 9

TECHNICAL DATA - ELECTRIC OVENS

MODEL	LENGHT X DEPTH X HEIGHT	KG NET	POWER	TENSION	
				Three phase Standard	Instal bridge supplied
WR-RVEL-E2	800x400x555	34 Kg	4,4 Kw	400v+N+T	220v mono.
WR-RVEL-E3	800x400x735	42,50 Kg	6,6 Kw	400v+N+T	
WR-RVEL-4E	800 x 400 x 915	54 kg	8,8 Kw	400v+N+T	

CHAPTER 6 ASSEMBLY OF SPARE PARTS

WARNING: These operations can only be done by an authorised technician

CHANGING DE MOTOR REDUCER

- a) remove the Disconnect the oven from the mains. Remove the cover of the transmission on the left side of the oven by loosening the screws fastening it.
- b) Loosen the screws (4) Fig. 10 to remove the chain that joins the pinion (3) and the axle of the first spit.
- c) Once the chain has been removed, totally remove the screws (4) to take out the motor support (5) along with the motor reducer.
- d) Loosen the screw fastening the pinion (3) to the axle of the motor reducer to remove it from the axle. Totally screws (2) to dismount the motor reducer from the support.
- e) Change the motor reducer and proceed in reverse order to what is explained above to assemble it.

WARNING When correctly tautened the motor chain should have a flexion in the centre of about 1 cm. An excessively taut chain produces unnecessary work stress on the motor reducer.

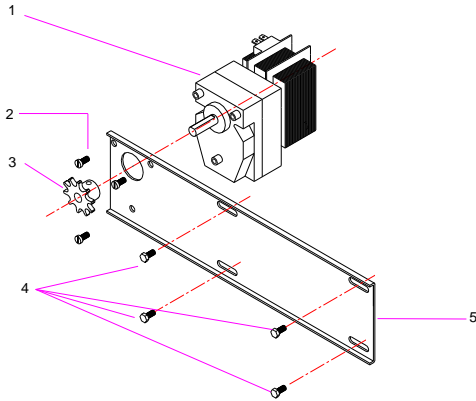
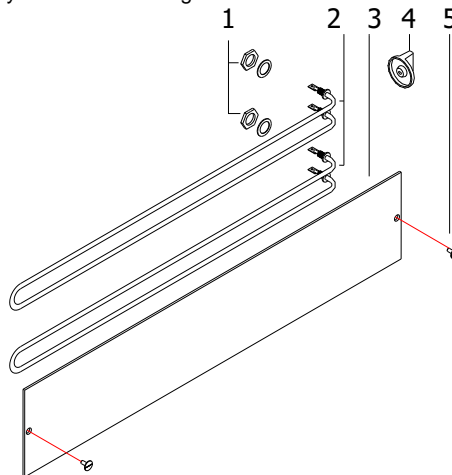

Fig. 10

CHANGING DE ELEMENTS

- a) Disconnect the oven from the mains. **ENSURE** that the oven is unplugged before proceeding.
- b) Pull the controls (4) (see Fig. 12) out of the switches. Remove the control panel by completely removing the screws that hold it in place. Remove the screws from the back panel and pull it to the left to remove it
- c) Remove the cables from the item to be replaced.
- d) Remove the glass (3) unscrewing the nuts (5) from the front.
- e) Remove the nuts (1) from the element (2) and remove it from its compartment.
- f) Change the element and proceed in reverse order as explained above to assemble it.

CHECK the connections have been made correctly before connecting the oven to the network.



APPENDIX A

LIST OF SPARE PARTS THAT MAY REQUIRE CHANGE

Denomination	Code
Motor reducer 220V	020112
Element	193100
Switch	060004
Spit without skewers	195001
Simple Skewer (without screw)	050107
Double Skewer	050110
Skewer screw	050116
Spit handle	050112
Hook for removing spits	050114
Oven glass, model.WR-RVEL-E2	194201
Oven glass, model. WR-RVEL-E3	194301
Oven glass, model. WR-RVEL-E4	194401