



DiVerso



MOD: WR-4B07-64

Production code: CEG/70_

08/2025

VI. SCHEMI DI INSTALLAZIONE – INSTALLATIONS PLAN - INSTALLATION DIAGRAM – SCHEMA D'INSTALLATION – ESQUEMA DE INSTALACION - INSTALLATIESCHEMA'S

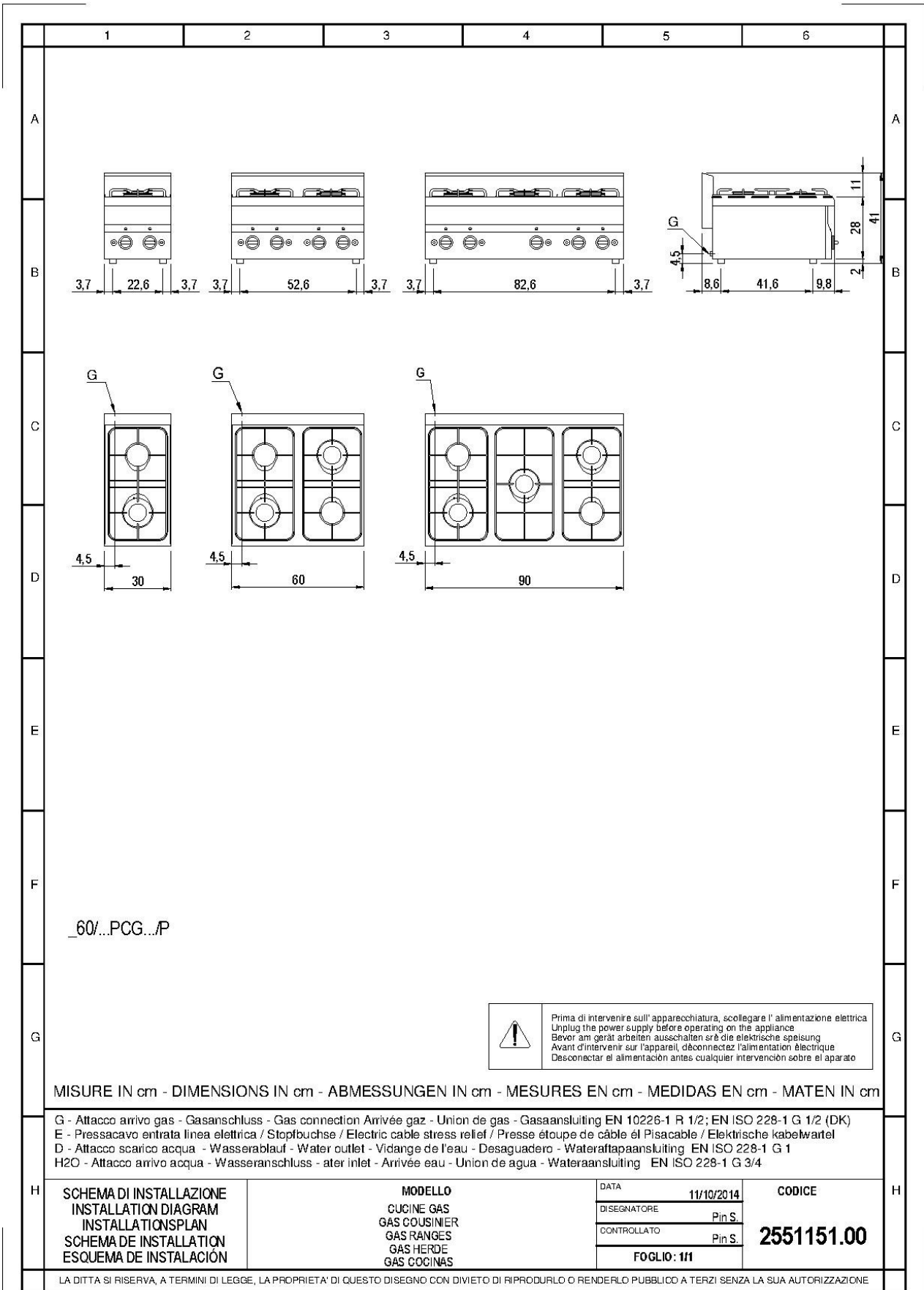

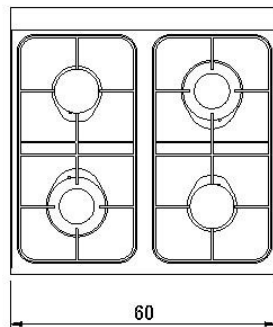
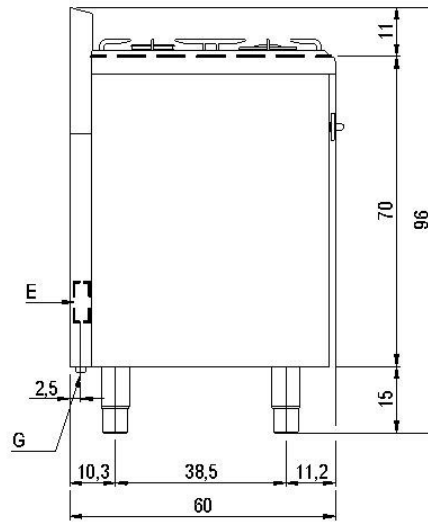
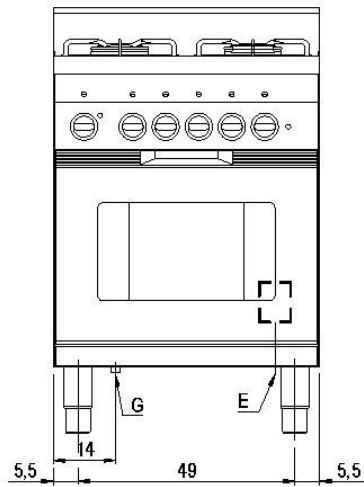

_60/...CFG

 Prima di intervenire sull'apparecchiatura, scollegare l'alimentazione elettrica
 Unplug the power supply before operating on the appliance
 Bevor am gerät arbeiten ausschalten srê die elektrische speisung
 Avant d'intervenir sur l'appareil, dëconnectez l'alimentation électrique
 Desconectar el alimentación antes cualquier intervencion sobre el aparato

MISURE IN cm - DIMENSIONS IN cm - ABMESSUNGEN IN cm - MESURES EN cm - MEDIDAS EN cm - MATEN IN cm

G - Attacco arrivo gas - Gasanschluss - Gas connection Arrivée gaz - Union de gas - Gasaansluiting EN 10226-1 R 1/2; EN ISO 228-1 G 1/2 (DK)
 E - Pressacavo entrata linea elettrica / Stopfbuchse / Electric cable stress relief / Presse étoupe de câble el Pisacable / Elektrische kabelwartel
 D - Attacco scarico acqua - Wasserablauf - Water outlet - Vidange de l'eau - Desaguadero - Wateraftapaansluiting EN ISO 228-1 G 1
 H2O - Attacco arrivo acqua - Wasseranschluss - ater inlet - Arrivée eau - Union de agua - Wateraansluiting EN ISO 228-1 G 3/4

SCHEMA DI INSTALLAZIONE
 INSTALLATION DIAGRAM
 INSTALLATIONSPLAN
 SCHEMA DE INSTALLATION
 ESQUEMA DE INSTALACIÓN

MODELLO
 CUCINE GAS
 GAS COUSINIER
 GAS RANGES
 GAS HERDE
 GAS COCINAS

DATA	11/10/2014
DI SEGNA TORE	Pin S.
CON TROLLATO	Pin S.
FOGLIO: 111	

CODICE
2551152.00

LA DITTA SI RISERVA, A TERMINI DI LEGGE, LA PROPRIETA' DI QUESTO DISEGNO CON DIVIETO DI RIPRODURLO O RENDERLO PUBBLICO A TERZI SENZA LA SUA AUTORIZZAZIONE

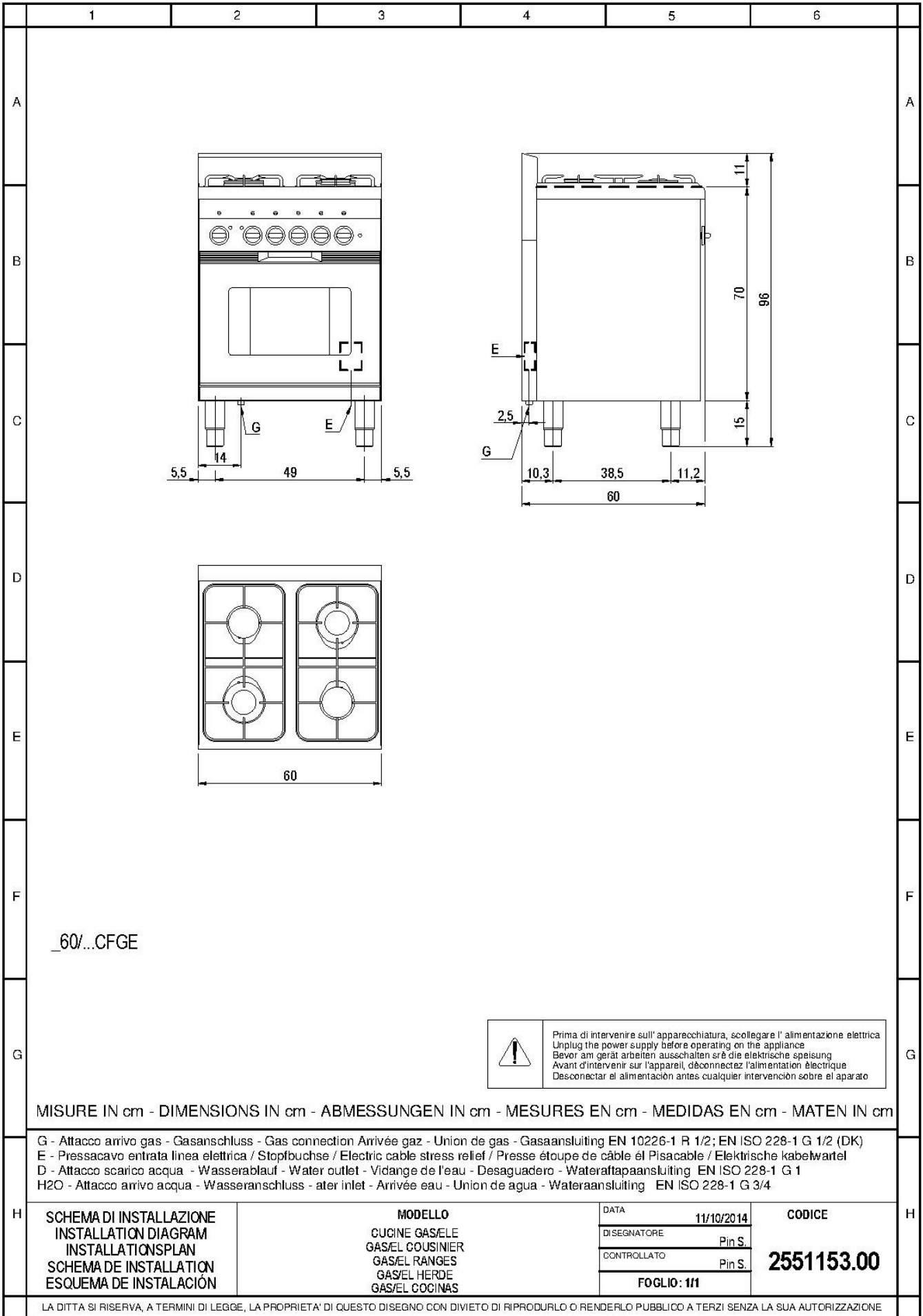

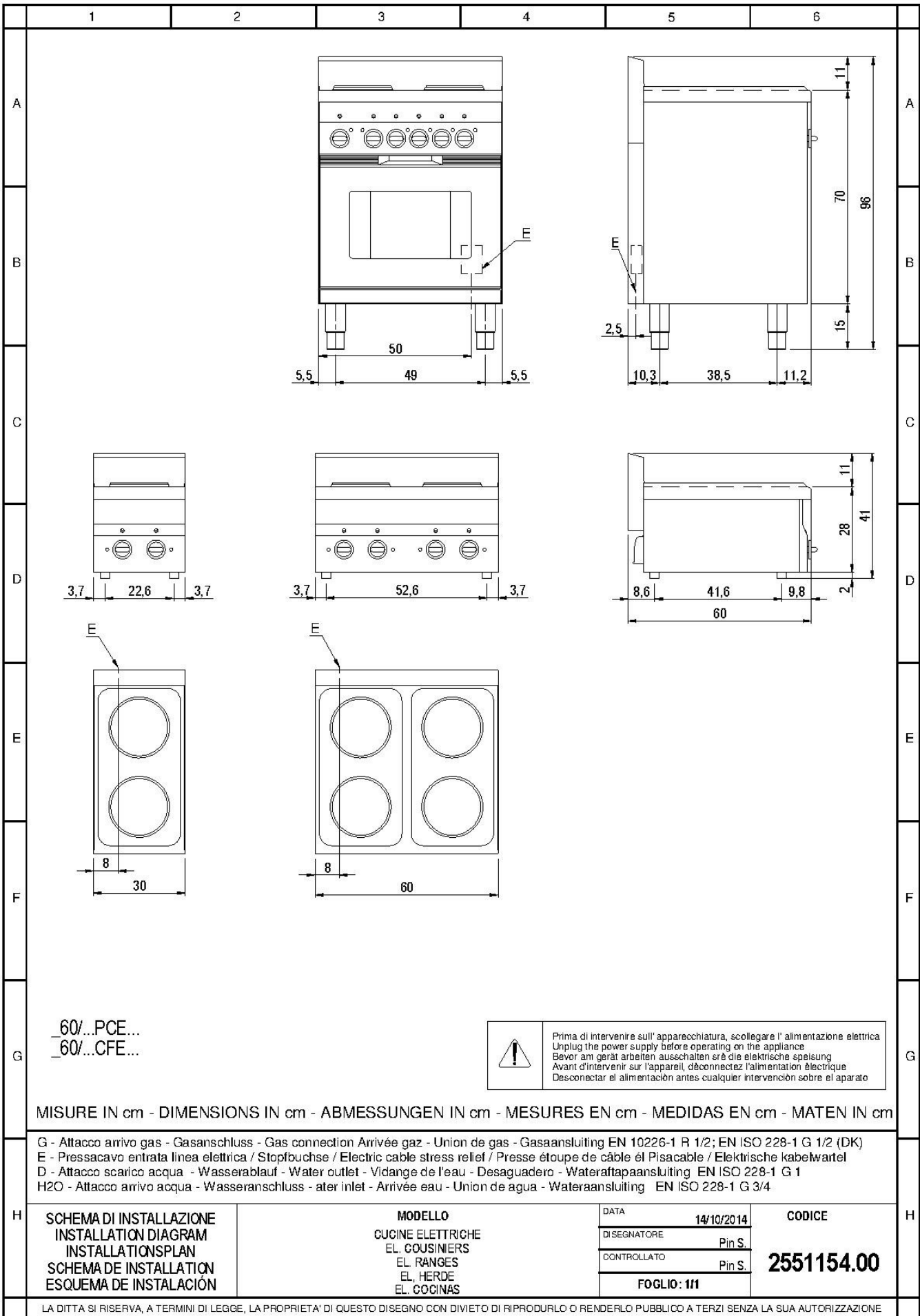

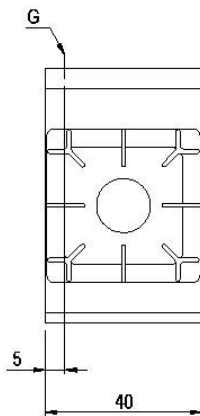
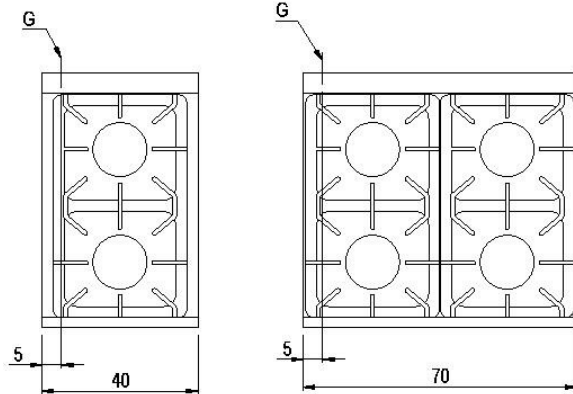
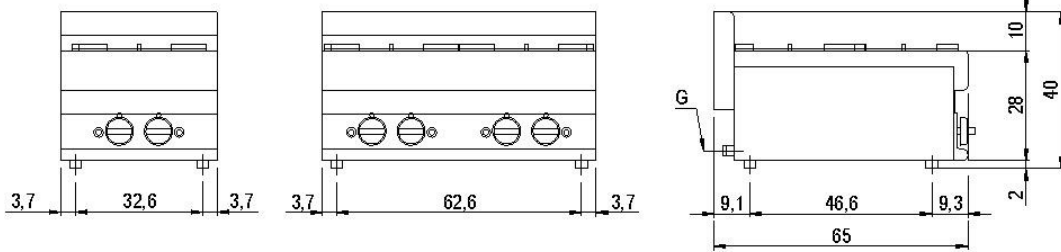

65/...PCG
65/...PG/40 P

 Prima di intervenire sull'apparecchiatura, scollegare l'alimentazione elettrica
Unplug the power supply before operating on the appliance
Bevor am gerät arbeiten ausschalten srê die elektrische speisung
Avant d'intervenir sur l'appareil, dëconnectez l'alimentation électrique
Desconnectar el alimentacion antes cualquier intervencion sobre el aparato

MISURE IN cm - DIMENSIONS IN cm - ABMESSUNGEN IN cm - MESURES EN cm - MEDIDAS EN cm - MATEN IN cm

G - Attacco arrivo gas - Gasanschluss - Gas connection Arrivée gaz - Union de gas - Gasaansluiting EN 10226-1 R 1/2; EN ISO 228-1 G 1/2 (DK)
E - Pressacavo entrata linea elettrica / Stopfbuchse / Electric cable stress relief / Presse étoupe de câble él Pisacable / Elektrische kabelwartel
D - Attacco scarico acqua - Wasserablauf - Water outlet - Vidange de l'eau - Desaguadero - Wateraftapaansluiting EN ISO 228-1 G 1
H2O - Attacco arrivo acqua - Wasseranschluss - ater inlet - Arrivée eau - Union de agua - Wateraansluiting EN ISO 228-1 G 3/4

SCHEMA DI INSTALLAZIONE
INSTALLATION DIAGRAM
INSTALLATIONSPLAN
SCHEMA DE INSTALLATION
ESQUEMA DE INSTALACIÓN

MODELLO
CUCINE GAS
GAS COUSINIER
GAS RANGES
GAS HERDE
GAS COCINAS

DATA	11/10/2014
DISEGNATORE	Pin S.
CONTROLLATO	Pin S.
FOGLIO: 111	

CODICE
2551155.00

LA DITTA SI RISERVA, A TERMINI DI LEGGE, LA PROPRIETA' DI QUESTO DISEGNO CON DIVIETO DI RIPRODURLO O RENDERLO PUBBLICO A TERZI SENZA LA SUA AUTORIZZAZIONE

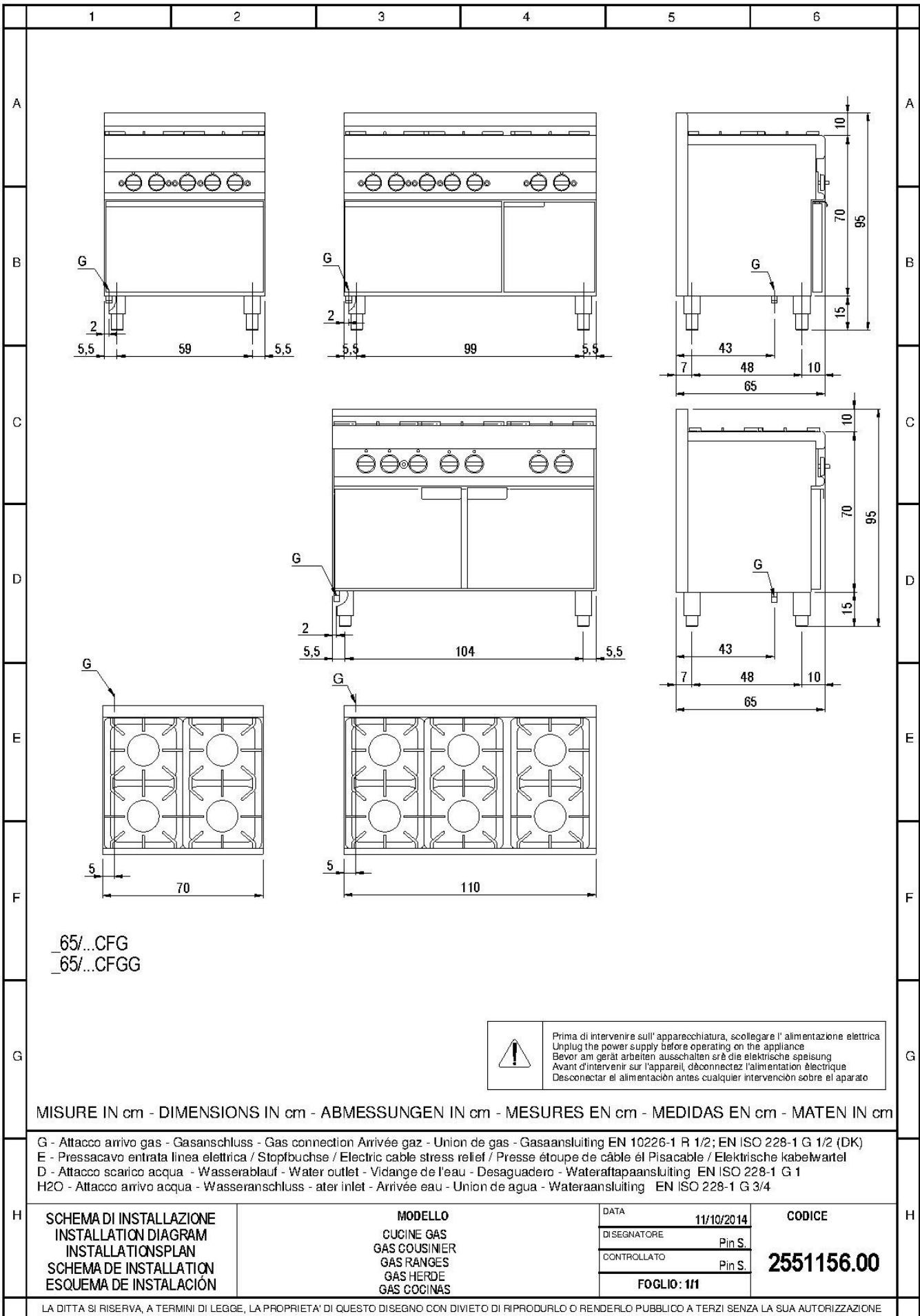

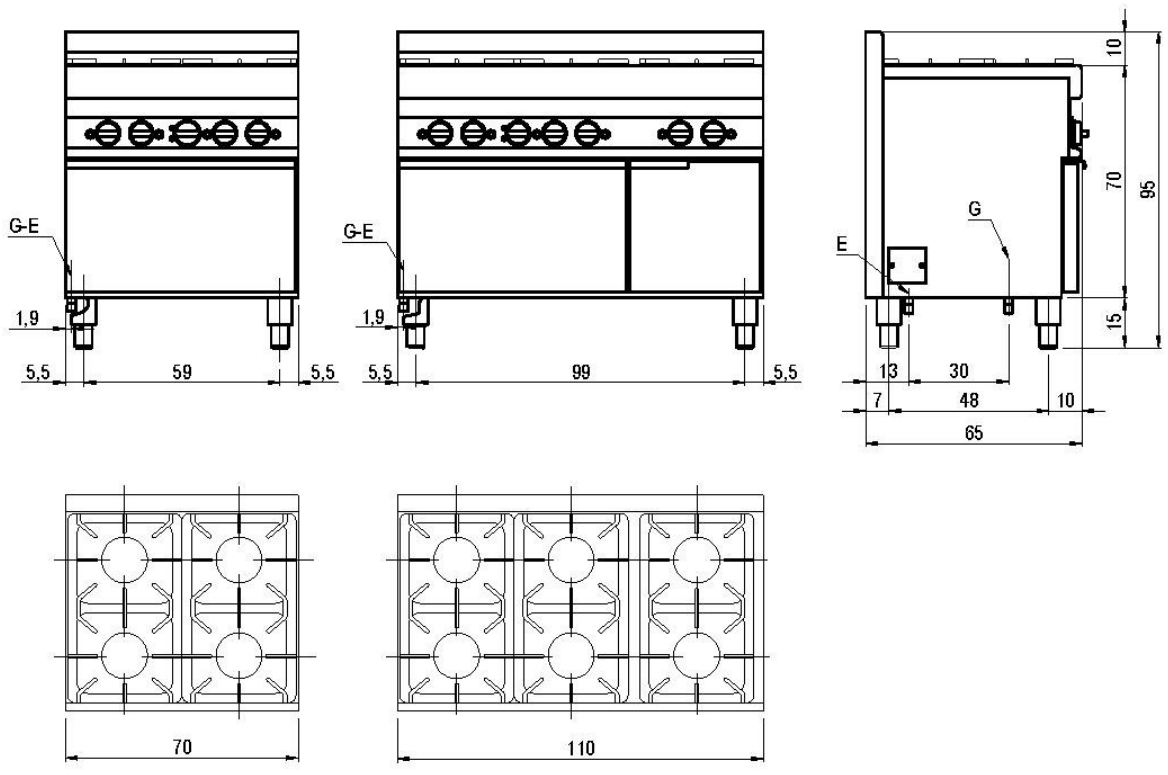

_65/...CFGE

 Prima di intervenire sull'apparecchiatura, scollegare l'alimentazione elettrica
 Unplug the power supply before operating on the appliance
 Bevor am gerät arbeiten ausschalten srê die elektrische speisung
 Avant d'intervenir sur l'appareil, dëconnectez l'alimentation électrique
 Desconectar el alimentación antes cualquier intervencion sobre el aparato

MISURE IN cm - DIMENSIONS IN cm - ABMESSUNGEN IN cm - MESURES EN cm - MEDIDAS EN cm - MATEN IN cm

G - Attacco arrivo gas - Gasanschluss - Gas connection Arrivée gaz - Union de gas - Gasaansluiting EN 10226-1 R 1/2; EN ISO 228-1 G 1/2 (DK)
 E - Pressacavo entrata linea elettrica / Stopfbuchse / Electric cable stress relief / Presse étoupe de câble el Pisacable / Elektrische kabelwartel
 D - Attacco scarico acqua - Wasserablauf - Water outlet - Vidange de l'eau - Desaguadero - Wateraftapaansluiting EN ISO 228-1 G 1
 H2O - Attacco arrivo acqua - Wasseranschluss - ater inlet - Arrivée eau - Union de agua - Wateraansluiting EN ISO 228-1 G 3/4

H	SCHEMA DI INSTALLAZIONE INSTALLATION DIAGRAM INSTALLATIONSPLAN SCHEMA DE INSTALLATION ESQUEMA DE INSTALACIÓN	MODELLO CUCINE GASELE GAS/EL COUSINIER GAS/EL RANGES GAS/EL HERDE GAS/EL COCINAS	DATA	11/10/2014	CODICE 2551157.00	H
			DISEGNATORE	Pin S.		
			CONTROLLATO	Pin S.		
			FOGLIO: 111			

LA DITTA SI RISERVA, A TERMINI DI LEGGE, LA PROPRIETA' DI QUESTO DISEGNO CON DIVIETO DI RIPRODURLO O RENDERLO PUBBLICO A TERZI SENZA LA SUA AUTORIZZAZIONE

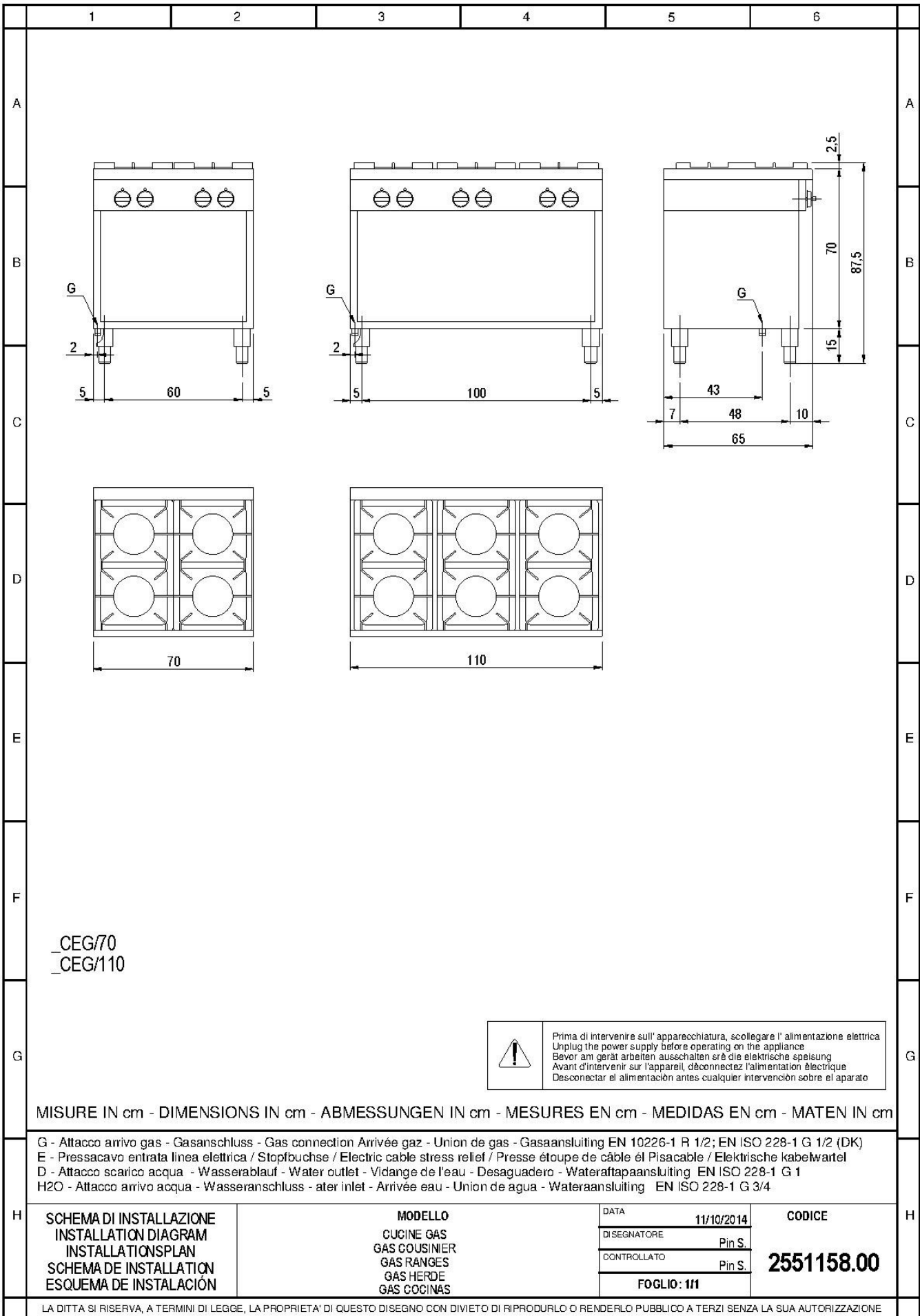

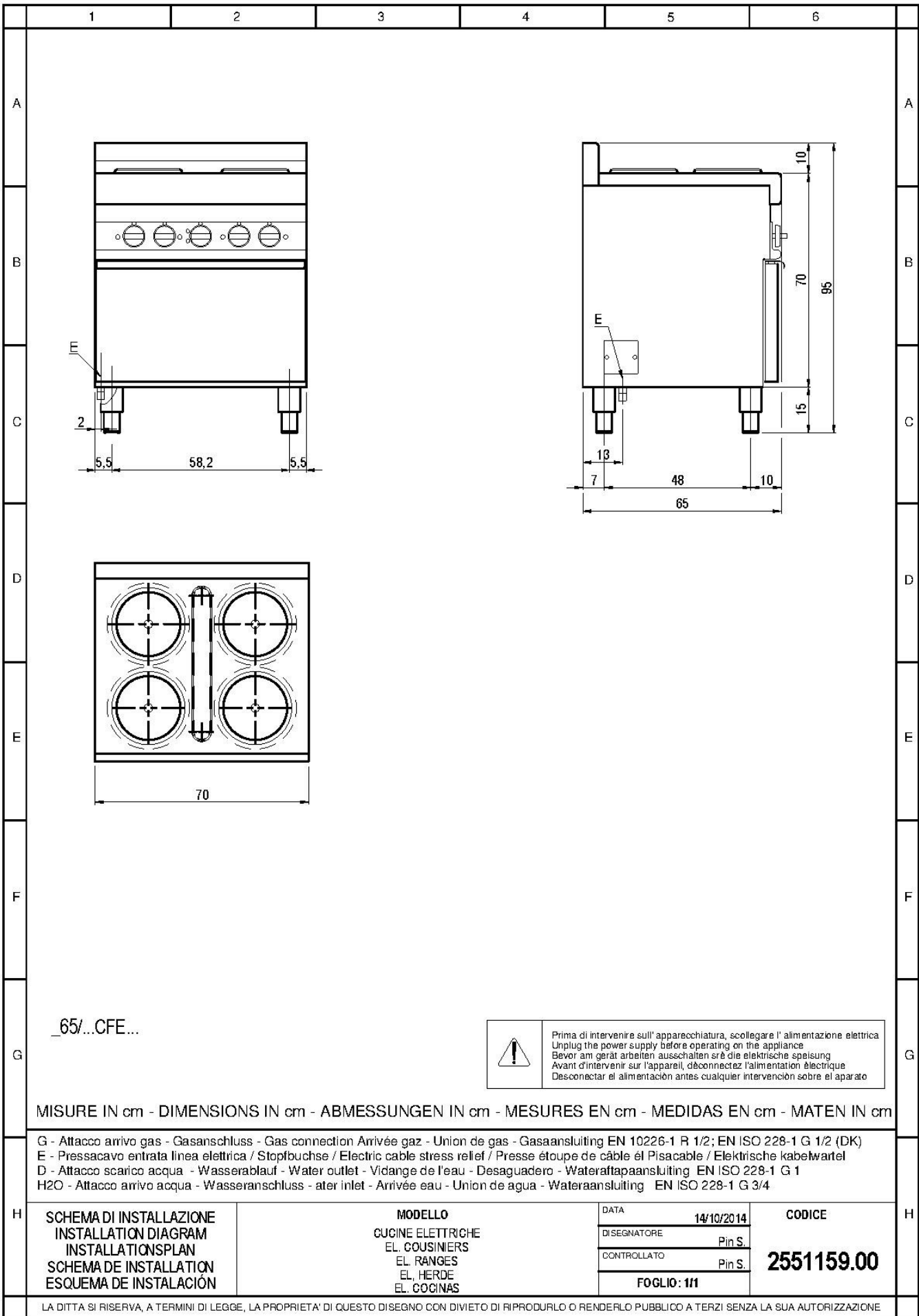

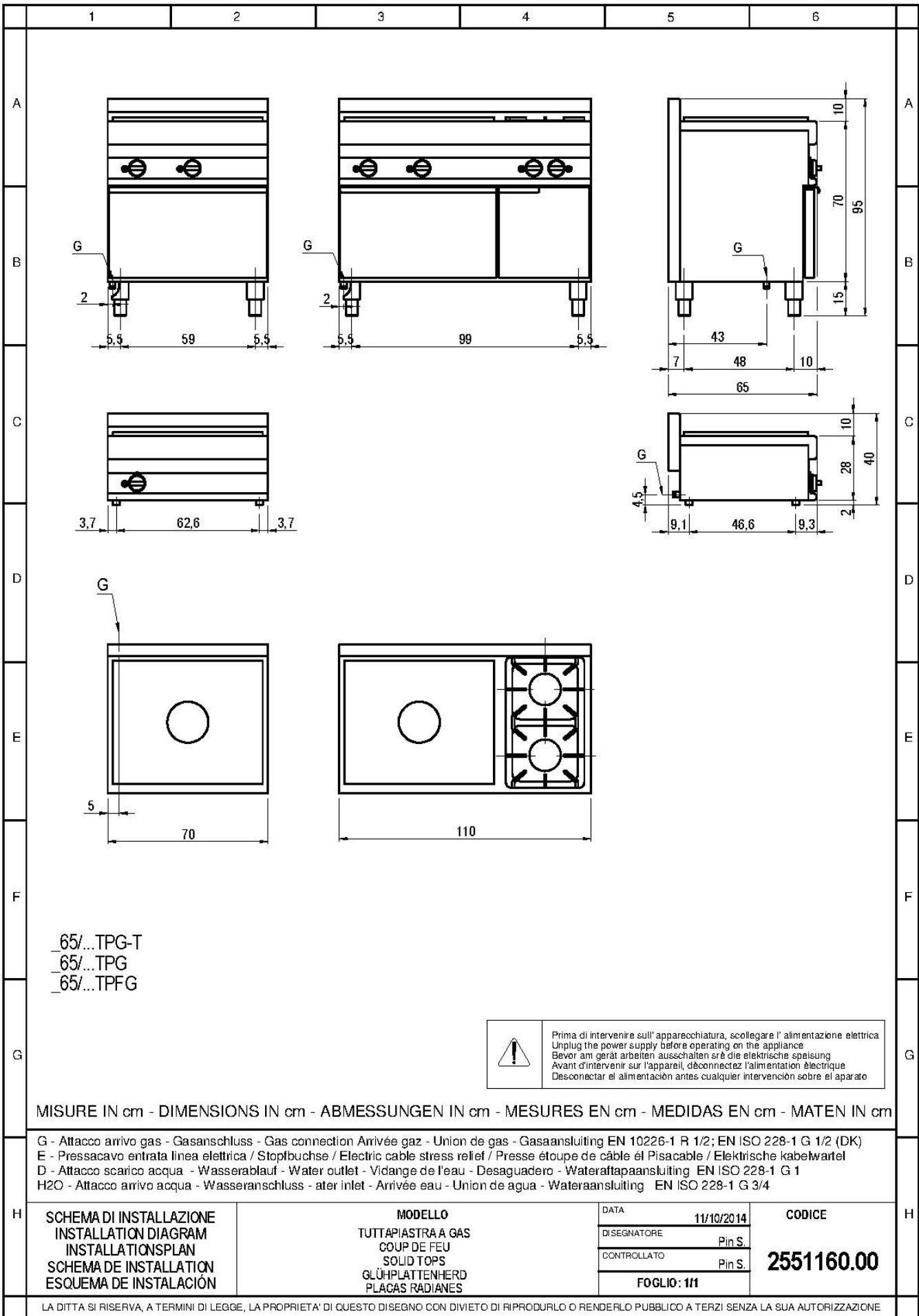

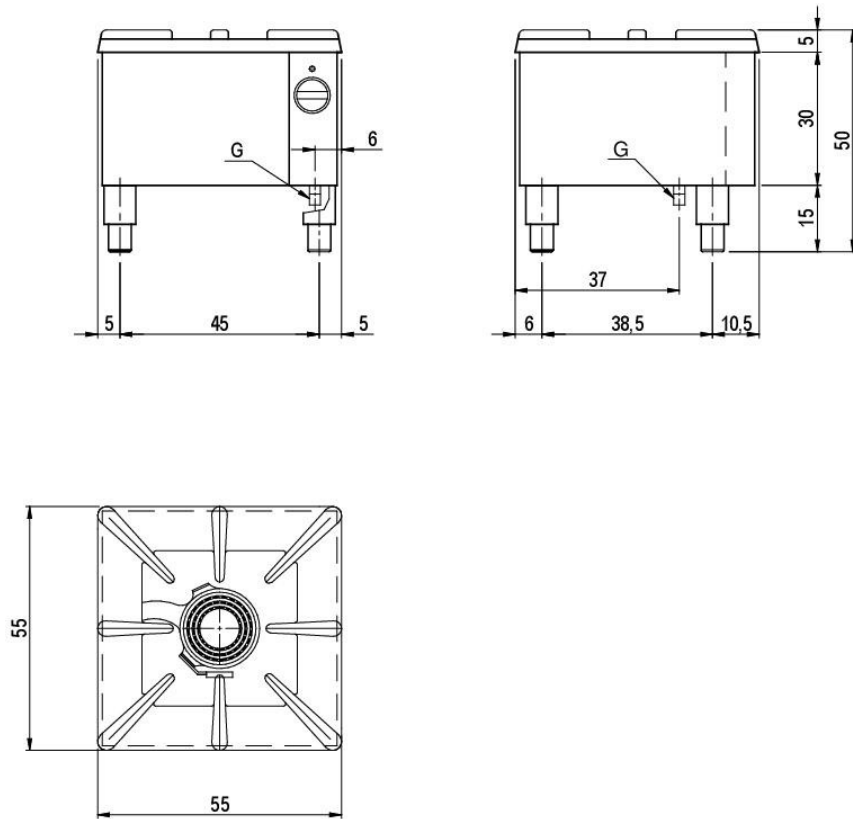

_FPG/55

 Prima di intervenire sull'apparecchiatura, scollegare l'alimentazione elettrica
 Unplug the power supply before operating on the appliance
 Bevor am gerät arbeiten ausschalten srè die elektrische speisung
 Avant d'intervenir sur l'appareil, déconnectez l'alimentation électrique
 Desconectar el alimentación antes cualquier intervención sobre el aparato

MISURE IN cm - DIMENSIONS IN cm - ABMESSUNGEN IN cm - MESURES EN cm - MEDIDAS EN cm - MATEN IN cm

G - Attacco arrivo gas - Gasanschluss - Gas connection Arrivée gaz - Union de gas - Gasaansluiting EN 10226-1 R 1/2; EN ISO 228-1 G 1/2 (DK)
 E - Pressacavo entrata linea elettrica / Stopfbuchse / Electric cable stress relief / Presse étoupe de câble él Pisacable / Elektrische kabelwartel
 D - Attacco scarico acqua - Wasserablauf - Water outlet - Vidange de l'eau - Desaguadero - Wateraftapaansluiting EN ISO 228-1 G 1
 H2O - Attacco arrivo acqua - Wasseranschluss - ater inlet - Arrivée eau - Union de agua - Wateraansluiting EN ISO 228-1 G 3/4

H	SCHEMA DI INSTALLAZIONE INSTALLATION DIAGRAM INSTALLATIONSPLAN SCHEMA DE INSTALLATION ESQUEMA DE INSTALACIÓN	MODELLO CUCINE GAS GAS COUSINIER GAS RANGES GAS HERDE GAS COCINAS	DATA	11/10/2014	CODICE
			DISEGNATORE	Pin S.	
			CONTROLLATO	Pin S.	2551161.00
			FOGLIO: 1/1		

LA DITTA SI RISERVA, A TERMINI DI LEGGE, LA PROPRIETA' DI QUESTO DISEGNO CON DIVIETO DI RIPRODURLO O RENDERLO PUBBLICO A TERZI SENZA LA SUA AUTORIZZAZIONE

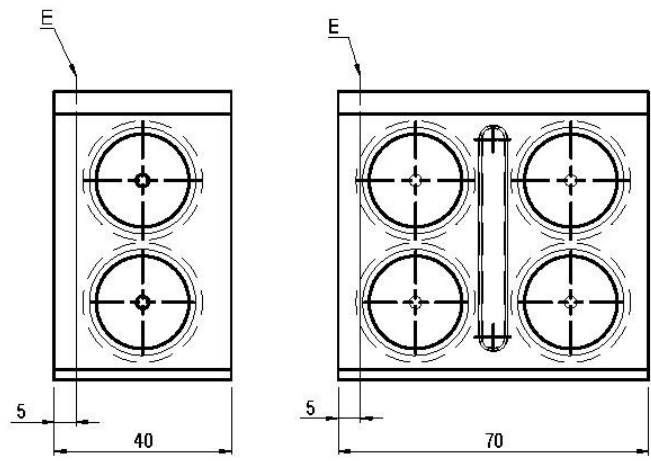
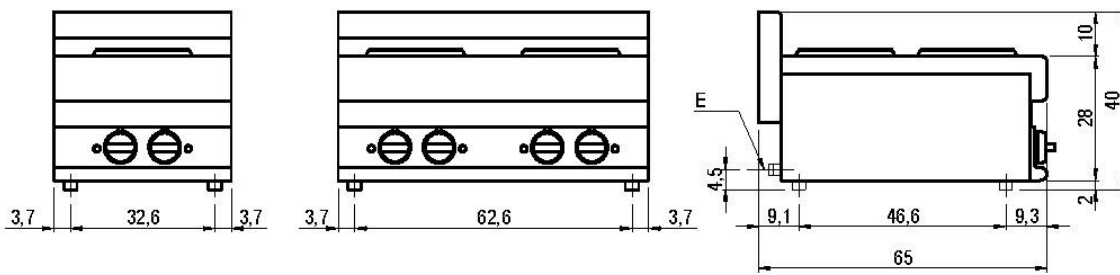

_65/...PCE...

 Prima di intervenire sull'apparecchiatura, scollegare l'alimentazione elettrica
 Unplug the power supply before operating on the appliance
 Bevor am gerät arbeiten ausschalten srê die elektrische speisung
 Avant d'intervenir sur l'appareil, dëconnectez l'alimentation électrique
 Desconectar el alimentacion antes cualquier intervencion sobre el aparato

MISURE IN cm - DIMENSIONS IN cm - ABMESSUNGEN IN cm - MESURES EN cm - MEDIDAS EN cm - MATEN IN cm

G - Attacco arrivo gas - Gasanschluss - Gas connection Arrivée gaz - Union de gas - Gasaansluiting EN 10226-1 R 1/2; EN ISO 228-1 G 1/2 (DK)
 E - Pressacavo entrata linea elettrica / Stopfbuchse / Electric cable stress relief / Presse étoupe de câble él Pisacable / Elektrische kabelwartel
 D - Attacco scarico acqua - Wasserablauf - Water outlet - Vidange de l'eau - Desaguadero - Wateraftapaansluiting EN ISO 228-1 G 1
 H2O - Attacco arrivo acqua - Wasseranschluss - ater inlet - Arrivée eau - Union de agua - Wateraansluiting EN ISO 228-1 G 3/4

H	SCHEMA DI INSTALLAZIONE INSTALLATION DIAGRAM INSTALLATIONSPLAN SCHEMA DE INSTALLATION ESQUEMA DE INSTALACIÓN	MODELLO CUCINE ELETTRICHE EL. COUSINIERS EL. RANGES EL. HERDE EL. COGINAS	DATA	14/10/2014	CODICE
			DISEGNATORE	Pin S.	
			CONTROLLATO	Pin S.	2551162.00
			FOGLIO: 111		

LA DITTA SI SERVA, A TERMINI DI LEGGE, LA PROPRIETA' DI QUESTO DISEGNO CON DIVIETO DI RIPRODURLO O RENDERLO PUBBLICO A TERZI SENZA LA SUA AUTORIZZAZIONE

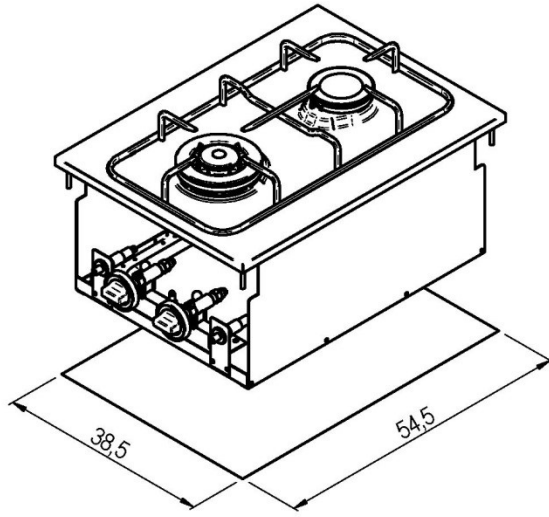
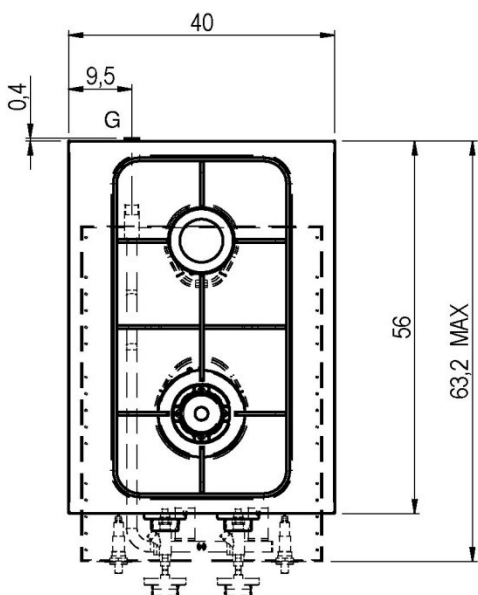
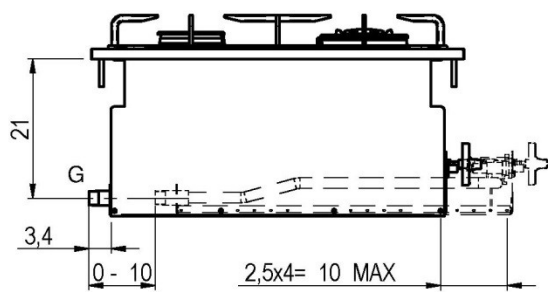
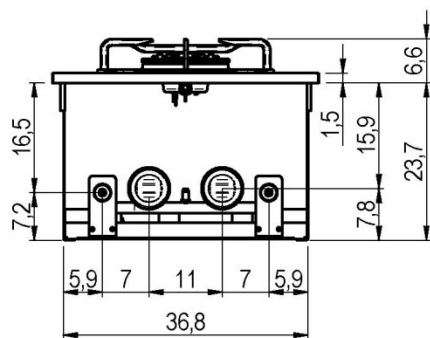

60/40 PCG-D

! Prima di intervenire sull'apparecchiatura, scollegare l'alimentazione elettrica
 Unplug the power supply before operating on the appliance
 Bevor am gerät arbeiten ausschalten srò die elektrische speisung
 Avant d'intervenir sur l'appareil, déconnectez l'alimentation électrique
 Desconectar el alimentación antes cualquier intervención sobre el aparato

MISURE IN cm - DIMENSIONS IN cm - ABMESSUNGEN IN cm - MESURES EN cm - MEDIDAS EN cm - MATEN IN cm

G - Attacco arrivo gas - Gasanschluss - Gas connection Arrivée gaz - Union de gas - Gasaansluiting EN 10226-1 R 1/2; EN ISO 228-1 G 1/2 (DK)
 E - Pressacavo entrata linea elettrica / Stopfbuchse / Electric cable stress relief / Presse étoupe de câble él Pisacable / Elektrische kabelwartel
 D - Attacco scarico acqua - Wasserablauf - Water outlet - Vidange de l'eau - Desaguadero - Wateraftapaansluiting EN ISO 228-1 G 1
 H2O - Attacco arrivo acqua - Wasseranschluss - ater inlet - Arrivée eau - Union de agua - Wateraansluiting EN ISO 228-1 G 3/4

H	SCHEMA DI INSTALLAZIONE INSTALLATION DIAGRAM INSTALLATIONSPLAN SCHEMA DE INSTALLATION ESQUEMA DE INSTALACIÓN	MODELLO PIANO COTTURA GAS DROP IN GAS BOILING UNIT DROP IN GASKOCHFELD DROP IN PLAN CUISSON GAZ DROP IN COCINA A GAS DROP IN	DATA	18/12/2014	CODICE
			DISEGNATORE	Possamai F.	
			CONTROLLATO	Possamai F.	2551074.00
			FOGLIO: 1/1		

LA DITTA SI RISERVA, A TERMINI DI LEGGE, LA PROPRIETA' DI QUESTO DISEGNO CON DIVIETO DI RIPRODURLO O RENDERLO PUBBLICO A TERZI SENZA LA SUA AUTORIZZAZIONE

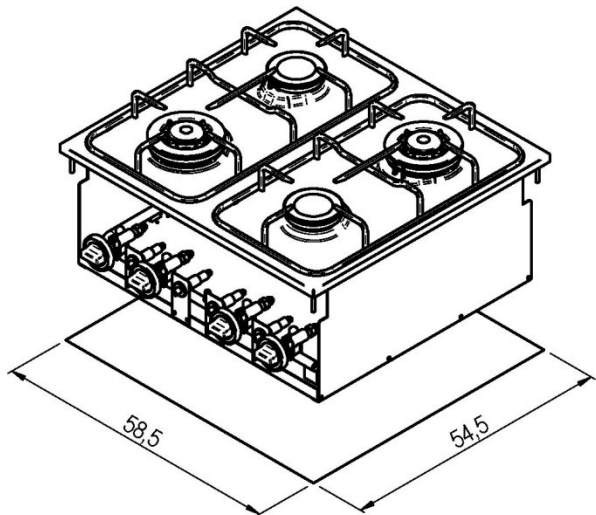
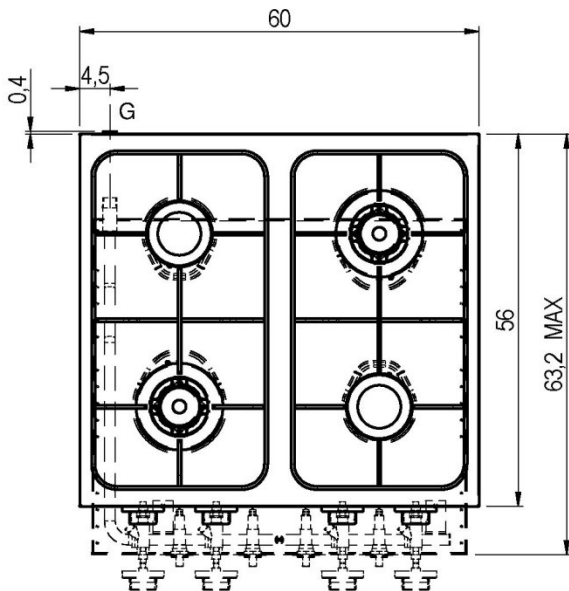
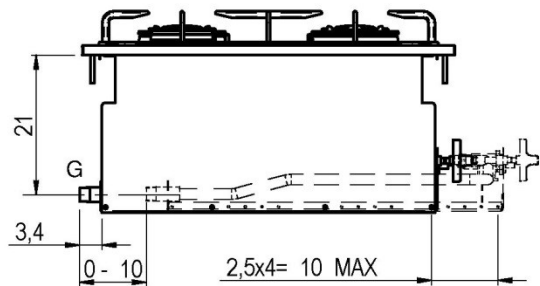
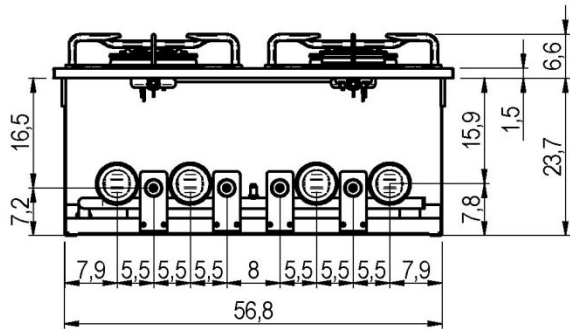

60/60 PCG-D

 Prima di intervenire sull'apparecchiatura, scollegare l'alimentazione elettrica
 Unplug the power supply before operating on the appliance
 Bevor am gerät arbeiten ausschalten srò die elektrishe speisung
 Avant d'intervenir sur l'appareil, déconnectez l'alimentation électrique
 Desconectar el alimentacion antes cualquier intervencion sobre el aparato

MISURE IN cm - DIMENSIONS IN cm - ABMESSUNGEN IN cm - MESURES EN cm - MEDIDAS EN cm - MATEN IN cm

G - Attacco arrivo gas - Gasanschluss - Gas connection Arrivée gaz - Union de gas - Gasaansluiting EN 10226-1 R 1/2; EN ISO 228-1 G 1/2 (DK)
 E - Pressacavo entrata linea elettrica / Stopfbuchse / Electric cable stress relief / Presse étoupe de câble él Pisacable / Elektrische kabelwartel
 D - Attacco scarico acqua - Wasserablauf - Water outlet - Vidange de l'eau - Desaguadero - Wateraftapaansluiting EN ISO 228-1 G 1
 H2O - Attacco arrivo acqua - Wasseranschluss - ater inlet - Arrivée eau - Union de agua - Wateraansluiting EN ISO 228-1 G 3/4

H	SCHEMA DI INSTALLAZIONE INSTALLATION DIAGRAM INSTALLATIONSPLAN SCHEMA DE INSTALLATION ESQUEMA DE INSTALACION	MODELLO PIANO COTTURA GAS DROP IN GAS BOILING UNIT DROP-IN GASKOCHFELD DROP IN PLAN CUISSON GAZ DROP IN COCINA A GAS DROP IN	DATA	18/12/2014	CODICE 2551075.00	H
			DISEGNATORE	Possamai F.		
			CONTROLLATO	Possamai F.		
			FOGLIO: 1/1			

LA DITTA SI RISERVA, A TERMINI DI LEGGE, LA PROPRIETA' DI QUESTO DISEGNO CON DIVIETO DI RIPRODURLO O RENDERLO PUBBLICO A TERZI SENZA LA SUA AUTORIZZAZIONE

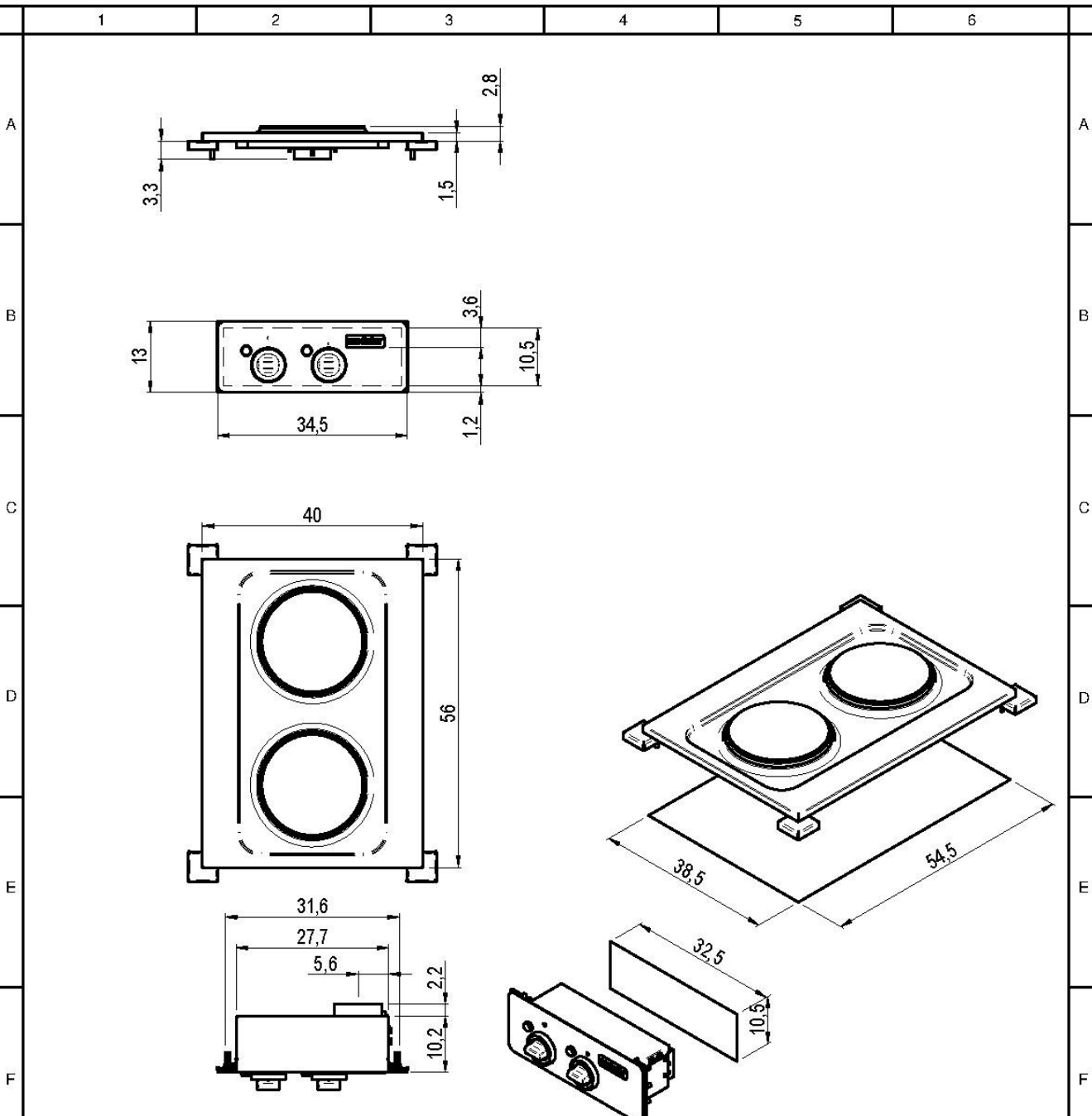

60/40 PCE-D

 Prima di intervenire sull'apparecchiatura, scollegare l'alimentazione elettrica
 Unplug the power supply before operating on the appliance
 Bevor am gerät arbeiten ausschalten srä die elektrische speisung
 Avant d'intervenir sur l'appareil, déconnectez l'alimentation électrique
 Desconectar el alimentación antes cualquier intervención sobre el aparato

MISURE IN cm - DIMENSIONS IN cm - ABMESSUNGEN IN cm - MESURES EN cm - MEDIDAS EN cm - MATEN IN cm

G - Attacco arrivo gas - Gasanschluss - Gas connection Arrivée gaz - Union de gas - Gasaansluiting EN 10226-1 R 1/2; EN ISO 228-1 G 1/2 (DK)
 E - Pressacavo entrata linea elettrica / Stopfbuchse / Electric cable stress relief / Presse étoupe de câble él Pisacable / Elektrische kabelwartel
 D - Attacco scarico acqua - Wasserablauf - Water outlet - Vidange de l'eau - Desaguadero - Wateraftapaansluiting EN ISO 228-1 G 1
 H2O - Attacco arrivo acqua - Wasseranschluss - ater inlet - Arrivée eau - Union de agua - Wateraansluiting EN ISO 228-1 G 3/4

H	SCHEMA DI INSTALLAZIONE INSTALLATION DIAGRAM INSTALLATIONSPLAN SCHEMA DE INSTALLATION ESQUEMA DE INSTALACIÓN	MODELLO PIANO COTTURA ELETTRICO DROP IN ELECTRIC COOKING TOP DROP IN ELEKTROKOCHFELD DROP IN TABLE DE CUISSON ELECTRIQUE DROP IN PLANO DE COCCION ELECTRICO DROP IN	DATA	18/12/2014	CODICE 2551076.13
			DISEGNAZIONE	Pessamai F.	
			CONTROLLATO	Pessamai F.	
			FOGLIO: 111		

LA DITTA SI RISERVA, A TERMINI DI LEGGE, LA PROPRIETA' DI QUESTO DISEGNO CON DIVIETO DI RIPRODURLO O RENDERLO PUBBLICO A TERZI SENZA LA SUA AUTORIZZAZIONE

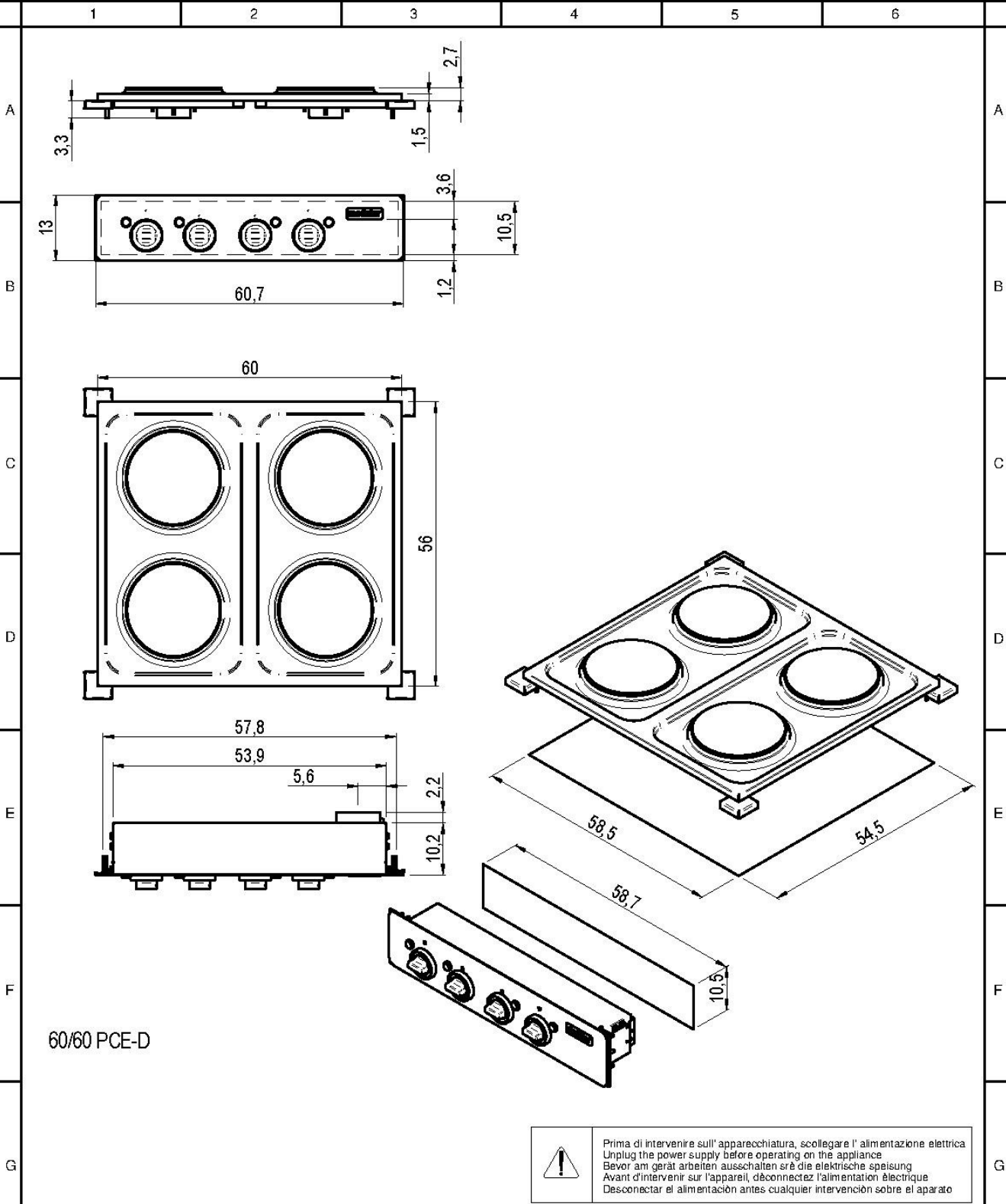

60/60 PCE-D

! Prima di intervenire sull'apparecchiatura, scollegare l'alimentazione elettrica
 Unplug the power supply before operating on the appliance
 Bevor am gerät arbeiten ausschalten srä die elektrische speisung
 Avant d'intervenir sur l'appareil, déconnectez l'alimentation électrique
 Desconectar el alimentación antes cualquier intervención sobre el aparato

MISURE IN cm - DIMENSIONS IN cm - ABMESSUNGEN IN cm - MESURES EN cm - MEDIDAS EN cm - MATEN IN cm

G - Attacco arrivo gas - Gasanschluss - Gas connection Arrivée gaz - Union de gas - Gasaansluiting EN 10226-1 R 1/2; EN ISO 228-1 G 1/2 (DK)
 E - Pressacavo entrata linea elettrica / Stopfbuchse / Electric cable stress relief / Presse étoupe de câble él Pisacable / Elektrische kabelwartel
 D - Attacco scarico acqua - Wasserablauf - Water outlet - Vidange de l'eau - Desaguadero - Wateraftapaansluiting EN ISO 228-1 G 1
 H2O - Attacco arrivo acqua - Wasseranschluss - ater inlet - Arrivée eau - Union de agua - Wateraansluiting EN ISO 228-1 G 3/4

H SCHEMA DI INSTALLAZIONE INSTALLATION DIAGRAM INSTALLATIONSPLAN SCHEMA DE INSTALLATION ESQUEMA DE INSTALACIÓN	MODELLO	DATA	18/12/2014	CODICE
	PIANO COTTURA ELETTRICO DROP IN ELECTRIC COOKING TOP DROP IN ELEKTROKOCHELD DROP IN	DISIGNATORE	Pessamai F.	2551077.13
	TABLE DE CUISSON ELECTRIQUE DROP IN PLANO DE COCCION ELECTRICO DROP IN	CONTROLLATO	Pessamai F.	
		FOGLIO: 111		

LA DITTA SI RISERVA, A TERMINI DI LEGGE, LA PROPRIETA' DI QUESTO DISEGNO CON DIVIETO DI RIPRODURLO O RENDERLO PUBBLICO A TERZI SENZA LA SUA AUTORIZZAZIONE

VII. FIGURE – ABB. – FIG. FIGURE-FIG.-IMAGE-ABB.-CIFRAS-AFBEELDINGEN

