

MOD : WR-GF15-G1

Production code : B-GF15S_

INSTALLATION, USE AND MAINTENANCE INSTRUCTIONS

GB

GAS FRYER

ACCORDING TO: EN 437 and EN 203 part 1 and 2 Cat. II for Natural gas and L.P.G.

WR-GF15-G1 WR-GF30-G2



INDEX

<i>CHAPTER</i>	<i>DESCRIPTION</i>	<i>PAGE</i>
	General notices	16
1.	Technical data	17
1.1	Gas fryer , Category II (Natural gas and L.P.G.)	17
1.2	Technical characteristics	17
2.	Installation instructions	18
2.1	Information about gas fryer	18
2.2	Laws, regulations and technical directives to be complied with	18
2.3	Installation place	18
2.4	Positioning	18
2.5	Table II: gas technical data, pressure, burner nozzles, pilot and idle screw unit type: WR-GF15-G1 with no. 1 15-litre tanks. Type: WR-GF30-G2 with no. 2 15-litre tanks	19
2.6	Gas system connection	19
2.7	Discharge of exhaust flue products	19
2.7.1	Gas units type A	19
2.8.1	Incoming pressure check (Pe)	19
2.8.2	Nozzle pressure check (Pi)	20
2.8.3	Liquid gas operation control	20
2.9	Operation control	20
2.10	Introduction to users	20
3.	Transformation to operate with other gas type	21
3.1	Replacing the main burner nozzle	21
3.2	Replacement of the pilot burner injector	21
3.3	Regulating the primary air, main burner	21
4.	Replacing important components	22
5.	Instruction for the user	23
5.1	Igniting the pilot	23
5.1.1	Igniting the main burner and adjusting the temperature	23
5.2	Switching off	23
5.3	Cleaning and notes	23
5.4	Cooking examples	24
5.5	Draining the oil tank	24
5.6	Temperature limiter	24
6.	Maintenance and cleaning	25
	INSTALLATION DIAGRAM	67

GENERAL NOTICES

- **Carefully read the instructions contained in the present booklet as they supply important information relating to safe installation, use and maintenance.**
- Keep this booklet with care, for any further consultation by the various operators.
- Having removed the packing, make sure the unit is in good order and in case of doubt, do not use the unit, but call on skilled personnel.
- Before connecting the unit, make sure the data appearing on the label correspond to those of the main gas supply.
- This unit must only be destined to the use it was expressly built for ; any other use must be deemed improper and therefore dangerous.
- The unit must be used only by a person trained for its operation.
- For any repairs, please call exclusively an authorised technical service centre, and ask for original spare parts only.
- Non compliance with the above may compromise the unit's safety.
- Do not wash the unit with direct or high-pressure water jets.
- Do not obstruct openings or draft grids or heat vents.

IN THE EVENT OF THE USER OR THE INSTALLATION TECHNICIAN FAILING TO OBSERVE THE INSTRUCTIONS GIVEN IN THIS MANUAL, THE FIRM DISCLAIMS ALL RESPONSIBILITY THEREOF AND CANNOT BE HELD LIABLE FOR ANY ACCIDENTS OR TROUBLE CAUSED BY SUCH NON-OBSERVANCE.

THE MANUFACTURER DISCLAIMS ALL RESPONSIBILITY FOR ANY INACCURACIES IN THIS BOOKLET THAT MAY BE DUE TO TYPING OR PRINTING MISTAKES. THE MANUFACTURER, MOREOVER, RESERVES THE RIGHT TO MAKE THE MODIFICATIONS TO THE PRODUCT IT CONSIDERS USEFUL OR NECESSARY, WITHOUT AFFECTING ITS BASIC FEATURES.

1.1 GAS FRYER, CATEGORY II (NATURAL GAS AND L.P.G.)

MODEL		WR-GF15-G1	WR-GF30-G2
Dimensions	Type	A	A
Width	mm	375	750
Depth	mm	650	650
Height	mm	845	845
Total Height	mm	1140	1140
Net Weight	kg	44	81
Tank dimensions and No.		1	2
Width	mm	250	250
Depth	mm	330	330
Height	mm	350	350
Tank capacity	l	15	15+15
Basket dimensions		1	2
Width	mm	235	235
Depth	mm	275	275
Height	mm	105	105
Pre-heating time (180K)	ca. min.	12	12
	°C / min.	16	16
Gas connection	"A"	1/2"	1/2"
Nominal thermal capacity	(1) kW	13	26(13+13)
Combustion air / fan	m ³ /h	21	42
Gas consumption	(15°C)		
L.P.G. G 30 G 31	g/h	1025/1010	2050/2020
Natural Gas H-G 20	m ³ /h	1,37	2,75
Natural Gas H-G 25	m ³ /h	1,60	3,20

(1) Including the pilot thermal capacity approx. 200W ; 2x200W for models with 2 burners/tank

1.2 TECHNICAL CHARACTERISTICS

Stainless steel frame AISI 304, stainless steel panels and base mounted on height-adjustable feet.

- **TANK** made of stainless steel AISI 304
- **GAS HEATING** by means of self-stabilising flame burners made of cast iron, assuring a high heating uniformity. Temperature thermostatic adjustment with safety valve and thermocouple for the interruption of gas in case of accidental extinguishment of the pilot burner. Piezoelectric ignition for pilot .
- **INDEPENDENT CONTROL** for the temperature of each tank, for models GF15+155 and GF25+255.

Installation must be performed by qualified technicians according to the law in force.

See technical data tables : 1.1 and 2.5-2.6.

WARNINGS:

Should the unit be installed against a wall, the latter must be heat-resistant to temperatures of 100°C and must be fireproof, or it has to be placed at a distance of 10 cm.

Before proceeding with the installation, remove the protective plastic film from the relevant parts, eliminating any adhesive residues with an appropriate cleaning product suitable for stainless steel.

Install the unit in a horizontal position; its correct levelling will be achieved by rotating the adjustable feet.

If the unit is installed by itself, it is advisable to fasten it to make its stability safer : especially for models WR-GF15-G1

NOTE: it is strictly forbidden to remove the feet of the fryer and install it on a cement base

2.1 INFORMATION ABOUT GAS FRYER

This manual applies to our Gas Fryers , Type A Category II (Natural Gas and L.P.G.).

See table 1.1 and 2.5-2.6.

The label according to EN437 and EN203 regulations, Part 1, is located:

a) inner door side

Example for Italy label:

Category II 2H3÷

Pe = Incoming Pressure

Pi = Nozzle Pressure

		Mod.			
		Matr.N°			
V	Hz	kW	Type	tipo	
IT-GR-GB-ES-IE		PT	FR-BE	NL	
Cat.	I12H3+	I12H3+	I12E+3+	I12L3P	mbar
P n	20,29/37	20,29/37	20/25,29/37	25,30,50	mbar
LU		IS-DK-FI-SE	AT-CH	DE	NO
Cat.	I12E3P	I12H3B/P	I12H3B/P	I12ELL3B/P	I3P
P n	20,37,50	20,29	20,50	20,20,50	30
ΣQn		G20		G30	
(Hi)		G25		G31	
	kW	m³/h		Kg/h	
		m³/h		Kg/h	

2.2 LAWS, REGULATIONS AND TECHNICAL DIRECTIVES TO BE COMPLIED WITH

The following indications should be observed during installation:

- Accident and fire regulations in force
- Prescriptions by the Gas Supply Company, which should issue an authorisation before installation.
- Instructions for the "Installation of gas equipment"
- Hygienic regulations.

2.3 INSTALLATION PLACE

- The unit should be installed in adequately ventilated places. (This unit requires a draft of at least 2 cu.m/hr x kW P.T. (Thermal capacity).
- Install the equipment in compliance with the safety rules applicable in the country where the equipment is installed.

2.4 POSITIONING

- The various units may be installed individually or together with other units of our range.
- This unit is not suitable for encasing.
- The distance between side walls must be a minimum of 10cm; should the distance be less or the wall or floor material be flammable, it is essential to use a thermal insulator.

2.5

**TABLE II: GAS TECHNICAL DATA, PRESSURE, BURNER NOZZLES, PILOT AND IDLE SCREW UNIT
TYPE: F15G/M WITH NO. 1 15-LITRE TANKS. TYPE: F15+15G/M WITH NO. 2 15-LITRE TANKS**

COUNTRY	NOZZLE CATEGORY	GAS TYPE	INCOMING GAS PRESSURE mbar			No. 1 BURNERS FOR EACH TANK		BY-PASS	PILOT	NOZZLE GAS PRESSURE 710 Eurosit		THERMAL CAPACITY NOM. kW (1)		GAS CONSUMPTION (15°C) FOR EACH TANK	
			Nom.	Min.	Max.	Ømm.Type STAMPED	R.o.A. Xmm.			Ømm. STAMPED	Ømm. STAMPED	Max.	Min.	100%	P.T.Min. ca.50%
ENG., ICEL., DENM., FIN., SWED., PORT., GREECE, IRELAND	2H	G 20	20	17	25	185 K	9,5	-	51	17,3	-	13	-	1376	-
NETHERLANDS	2L	G 25	25	20	30	200 L	18,5	-	51	21,4	-	13	-	1600	-
ICEL., DENMARK, FINLAND, SWEDEN	3B/P	G 30* G 31	29	25	35	125 K	13	-	30	28,3	-	13	-	404 466	1025 885
GREECE ENGLAND	3+	G 30* G 31	29 37	20 25	35 45	125 K	13	- -	30	28,3 36,7	- -	13	-	406 532	1025 1010
NORWAY	3P	G 31*	30	25	35	135 K	11	-	30	28,9	-	13	-	532	1010
IRELAND PORTUGAL	3P	G 31*	37	25	45	125K	13	-	30	36,1	-	13	-	532	1010
NETHERLANDS	3P	G 31*	50	42,5	57,5	115K	10	-	30	49,1	-	13	-	532	1010

R.o.A. = Regulation of primary air (1) Including the pilot thermal capacity approx WR-GF15-G1: 200W; WR-GF30-G2: 2x200W.
Nozzle marking Ø 1/100 * Pressure regulator excluded K = Short nozzle l = 15 mm F = Fixed A = Adjustable

2.6 GAS SYSTEM CONNECTION

- The unit should be supplied with gas having the characteristics and the pressure shown on Table II.
- The gas pressure is measured at the initial pressure outlet with the burner on (see Fig. 1) and art. 2.9.1.
- The equipment is tested and preset in order to work with the gas indicated on the external adhesive plate.

***N.B. Should the supply pressure vary more than +10% of the nominal pressure, it is advisable to install a pressure regulator ahead of the unit to guarantee the nominal pressure.**

- Gas supply connection should be performed by means of metal piping of an appropriate cross section and an approved shutoff cock should be fitted at source.
- Having connected the gas supply, you should make sure no leaks exist at the joints by checking with bubble soap.

2.7 DISCHARGE OF EXHAUST FLUE PRODUCTS

The units should be installed in premises suitable for the discharge of flue products, which must occur in compliance with the installation instructions. Our equipment (see Table 1.1 for technical data) is classified as:

2.8.1 GAS UNITS TYPE A

They are not suitable to be connected to a flue discharge control.

The gas unit should be positioned beneath a draft hood with its system complying with the Regulations. (This unit needs at least 2cu.m/hr • kW T.C. (Thermal Capacity).

Check kitchen ventilation: it should be complying with the Regulations in force.

2.8.1 INCOMING PRESSURE CHECK (PE)

Pressure is measured with a manometer 0÷80mbar (precision at least 0.1mbar).

The pressure socket Fig. 1 is located on the G 1/2" gas ramp behind the panel; undo the screw (A) of the pressure socket (B), attach the silicone rubber to the manometer, ignite the burner and take the incoming "dynamic" pressure.

Fasten the screw (A) back with a gas washer (C), check gas sealing with bubble soap.

See also the publication "Installation Regulations and Characteristics of L.P.G. Systems".

2.8.2 NOZZLE PRESSURE CHECK (PI)

The pressure socket is located above the nozzle holder.

The silicone rubber is prepared for high temperatures and should be protected with tin foil to avoid its burning.

2.8.3 LIQUID GAS OPERATION CONTROL

Check whether the fitted nozzles comply with the indications on Table II.

Check whether the incoming pressure complies with the indications on Table II.

Make sure that the L.P.G. gas system has two pressure regulators of suitable capacity and that the evaporation capacity is sufficient. See also the publication "Installation Regulations and Characteristics of L.P.G. Systems".

2.9 OPERATION CONTROL

- Start the unit in accordance with the use instructions Chap. 5.
- Make sure there are no leaks following the local procedures.
- Check the ignition and interignition of the pilot burner and the main burner.
- Make sure the flue gases are discharged regularly.
- Write on a sticker to be glued to the unit label, for what gas and pressure the unit has been calibrated.

2.10 INTRODUCTION TO USERS

Explain the operation and use of the Fryer to its user by consulting the manual, and illustrate any changes.

Leave this instruction manual with the user and explain he/she must consult it for any future reference.

3.

TRANSFORMATION TO OPERATE WITH OTHER GAS TYPE

Shut off the gas valve supplying the unit.

3.1 REPLACING THE MAIN BURNER NOZZLE (FIG. 5)

- Open the cabinet door and remove the oil containers.
- Loosen screw (D) and press the primary air regulator (C) in the venturi.
- Using a size-12 spanner, unscrew nozzle (B) and replace it with the one corresponding to the selected gas, according to the indications on Table II Ch. 2.5-2.6.

3.2 REPLACEMENT OF THE PILOT BURNER INJECTOR (FIG. 6)

- Remove the locknut of the gas pipe with a 10 mm wrench (Fig. 6 Pos. 2) without breaking the glow plug.
- Remove the pilot injector (Fig. 6 Pos. 7) and replace it with the one fit for the gas pipe.
- Place the nut back in its position and tighten.
- Check for gas leaks.

IMPORTANT - When converting or adapting to another type of gas, it is compulsory to affix the corresponding initials (sticker supplied together with nozzles) onto the technical data plate.

3.3 REGULATING THE PRIMARY AIR, MAIN BURNER

- Start up the unit by following the user instructions.
- Check the gas seal with soapy water, ignite the pilot by following the operating instructions and check it. The flame must invest the thermocouple ; if it does not do so, check the pilot injector (Fig. 6 pos. 7).
- To check the primary air regulation for the main burners, distance "X" should be adjusted in a correct manner (see injector Table II Ch. 2.5-2.6 and Fig. 5 position C) ; a correct primary air regulation prevents, the flames from lifting off when the burner is cold, and from returning when the burner is hot.
- Check the inter-ignition and the flame regularity on maximum.

After replacing the nozzles, apply on the existing label the one supplied with the machine indicating the new type of gas.

The unit should be checked at least twice a year. You must check the burners, the ignition, the interignition, the maximum and minimum settings and the air inlet.

For any repairs, consult exclusively an authorised assistance centre and ask for original spare parts.

Before carrying out the disassembling of components and their replacement, shut off the gas valve.

Open the door and remove the front panel.

Pull out the oil collecting tray, then proceed to replace the most important components:

A) Piezoelectric Igniter

- Detach the high-voltage wire from the igniter
- Unscrew the screw located under the switch-on button by means of a cross screw-driver (Fig. 9)
- Replace the igniter
- Mount everything back by following the reverse order sequence.

B) Pilot spark-plug “Ignition Ramp” (Fig. 6 position 5)

- Remove the high-voltage cable
- Unscrew the two screws (Fig. 6 position 8) using a 8mm-spanner
- Replace the spark-plug
- Mount everything back by following the reverse order sequence.

C) Thermocouple (Fig. 6 position 4)

- Unscrew the nut (Fig. 6 Pos. 9) with a 10 mm wrench and remove the thermocouple.
- With a 9mm-spanner, unscrew the thermocouple from the safety valve (Fig. 10)
- Mount everything back by following the reverse order.

D) Pilot burner “Ignition Ramp” (Fig. 6 position 6)

- Remove the gas connection by using a 10mm-spanner (Fig. 6 position 2).
- Disconnect the high-voltage wire.
- Undo the two screws (Fig. 6 position 1) with a Phillips screwdriver.
- Remove the spark-plug (Fig. 6 position 1) and the thermocouple (Fig. 6 position 4).
- Change the pilot assembly (Fig. 6 position 6).
- Mount everything back by following the reverse order.

ATTENTION : Check the gas seal with soap bubbles.

E) Thermostat valve

- Remove the bulb from the bushing (Fig. 8 pos. 1)
 - Remove the gas pipe from the valve outlet
 - Undo the 4 screws of the upper gas inlet flange
- ATTENTION : Carefully check the O.R. gas seal.
- Remove the thermocouple with a 9mm-spanner.
 - Remove the pilot burner gas supply pipe by using a 10mm-spanner.
 - Change the old thermostat valve with a new one.

ATTENTION : The buttons must be as indicated in Fig. 9, do not forget the thermocouple interruption!

- Mount everything back by following the reverse order.
- Adjust the bypass idle screw (100% open !)
- Mount back the valve pipe and the limit thermostat bulb.

ATTENTION : Check the gas seal with soap bubbles.

Check that the oil temperature reaches 195°C with the thermostat on position 8.

F) Burner (Fig. 5)

- Unscrew the nut (Fig. 5 pos. E)
- Unscrew the upper nut on the plate by using an 13mm-spanner.
- Unscrew the screw on the plate by using an 10mm-spanner.

Now you can replace the burner.

- Mount everything back by following the reverse order.

ATTENTION : Check the gas seal with soap bubbles.

G) Safety thermostat (Fig. 10)

- Check the operation and find the reason causing the thermostat to come on. Its replacement is very easy.

ATTENTION : The thermostat interrupts the thermocouple circuit.

Foreword

Before you start up the unit, thoroughly wash the tank and the baskets, operating as follows :

- Fill up the tank to level with water and detergent, switch on the heating and bring to boiling point for a few minutes, drain the water through the drain tap and thoroughly rinse the tank with clean water.
- If you use fat for frying, do not place it in the tank unless it is in a liquid state.
- During usage, we recommend not to cover the tank or put salt or spices into it.
- **Never switch on the unit before you have filled the tank with oil. Non-compliance with this rules would cause serious damage due to overheating at tank.**

FILLING IN THE TANK (Fig. 8)

Make sure the drain tap is closed, then pour oil into the tank to reach the MIN. Mark, and anyway not beyond the MAX . mark. See Technical Data Table 1.1 for tank capacity.

FILLING IN THE BASKET

The quantity of food to be placed into the basket depends on how you wish to cook it. On dipping it into the oil, you should avoid a sudden drop in oil temperature, in any case preventing its dropping below 160°C.

Small bits of food cooked for the right length of time are actually better than a big chunk to be cooked for a longer period.

5.1 IGNITING THE PILOT (FIG. 9)

- Open the gas valve supplying the unit.
- Turn the temperature regulating knob and bring it to Position (★), then open the unit door.
- Press and keep the pilot button pressed until ignition occurs, and at the same time press the ignition button several times for 20 seconds, until all the air contained in the piping is expelled and the pilot ignites (you can check that by looking through the open unit door).

5.1.1 IGNITING THE MAIN BURNER AND ADJUSTING THE TEMPERATURE

Having ignited the pilot, the burner is activated by turning the knob and bringing it to position 8.

Oil temperature adjustment occurs by turning the knob to positions from 1 to 8 :

KNOB POSITION	OIL TEMPERATURE
1	118 ± 8 °C
2	127 ± 8 °C
3	138 ± 8 °C
4	148 ± 8 °C
5	157 ± 8 °C
6	170 ± 8 °C
7	181 ± 8 °C
8	192 ± 8 °C

5.2 SWITCHING OFF

The main burner can be switched off by turning the knob and bringing it to the pilot igniting position (★).

To extinguish the pilot too, press the button marked (●).

N.B. : The button stays automatically in position for approximately 90 seconds ; during this period, the unit stays off.

5.3 CLEANING AND NOTES

When cleaning, please comply with the following instructions :

- Clean everything without using metal wool or abrasive products.
- We recommend that the oil or fat you use for cooking be of good quality and without impurities ; these should be removed by filtration.
- Before pouring fresh or filtered oil into the tank, make sure the latter is thoroughly clean.
- Place the lid on the unit when not in use.

5.4 COOKING EXAMPLES

FOOD	TIME IN MINUTES	THERMOSTAT °C
Crostini	1	180
Prawns and cuttle-fish	2 - 5	180
Crumbed fish fillets	2 - 4	190
Mixed fried fish	3 - 5	190
Sausages	2 - 4	170 - 180
Chickens	10 - 15	170 - 180
Spring chickens	5 - 8	180
Miscellaneous roasts (from 1 to 2kg.)	20 - 25	170
Potato chips	3 - 5	190
Browning potato chips	1 - 2	190
Artichoke ends, egg plant, cauliflower, zucchini	2 - 4	190
Fritters	2 - 4	180
Rice croquettes	3 - 5	160 - 180

5.5 DRAINING THE OIL TANK (FIG. 4)

To drain the tank open the appropriate tap : the oil will automatically flow out through a filter and into an oil collecting tray. It is necessary to periodically check that the oil level in the oil collecting tray does not reach the rim and that the filter is clean. Empty it and/or clean the filter, if needed.

A removable handle placed on the upper edge facilitates the extraction and emptying of the oil collecting tray with both hands

5.6 TEMPERATURE LIMITER

The fryers are fitted with a safety thermostat (Fig. 10) which is activated in case of oil overheating.

When this thermostat has intervened, to have the unit start again you need to reset the thermostat itself (Fig. 10).

Such an operation should be performed by qualified personnel, who will check the causes for the thermostat activation.

- Clean the stainless steel parts daily with soapy lukewarm water, then rinse well and dry thoroughly.
- Absolutely avoid to clean the stainless steel with common steel-wool, or common steel brushes and scrapers, as they may discard ferrous particles which, on depositing, cause rust spots. You may, if you like, use stainless steel-wool passed on following the butter-finish direction.
- Should the unit remain unused for long periods, heavily rub all the steel surfaces with a cloth slightly wetted with vaseline oil, in order to cover them with a protective film. Periodically ventilate the premises.

COOKING TANKS

- Drain the tanks from the oil by having it flow through the drain tap into the oil collecting tray, then thoroughly clean them by using an appropriate detergent and avoiding to scrape or scratch the tank bottom. Rinse well, so as to remove all traces of detergent.

STAINLESS STEEL PARTS

- The stainless steel parts must be cleaned with soapy water and then dried with a soft cloth. The bright polish is kept by periodical wiping with liquid (POLISH), a product easily available.

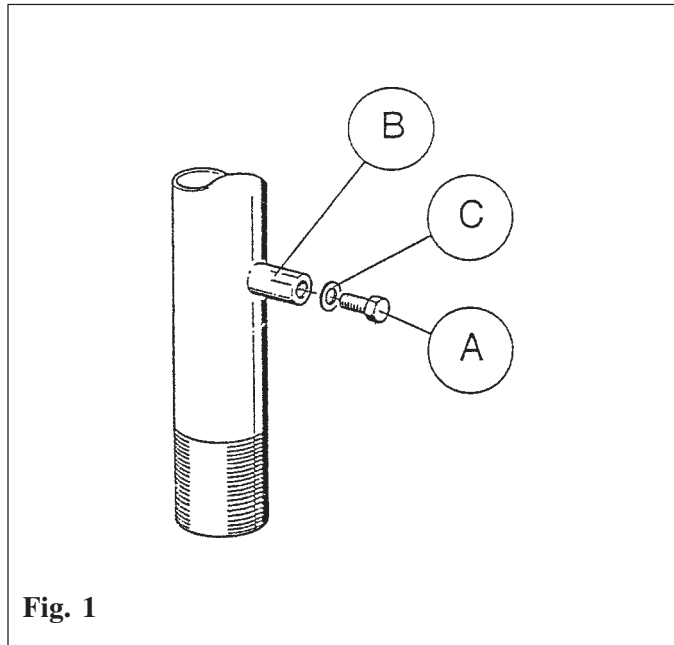

Fig. 1

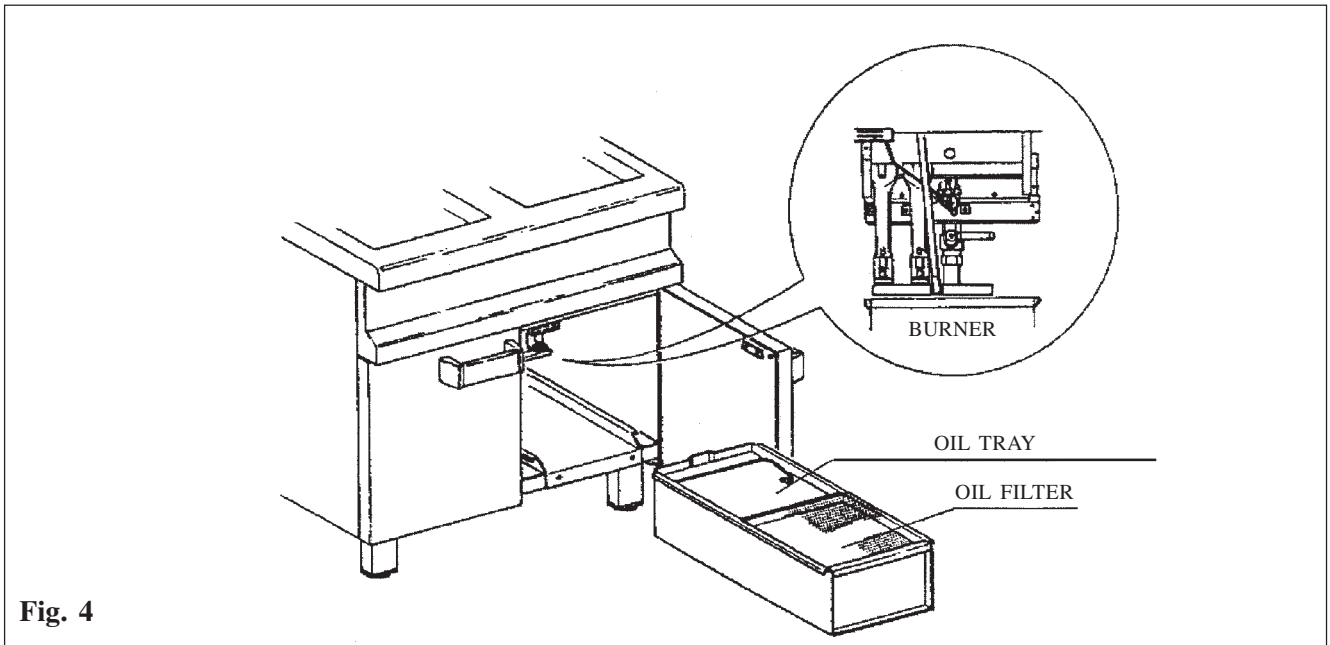

Fig. 4

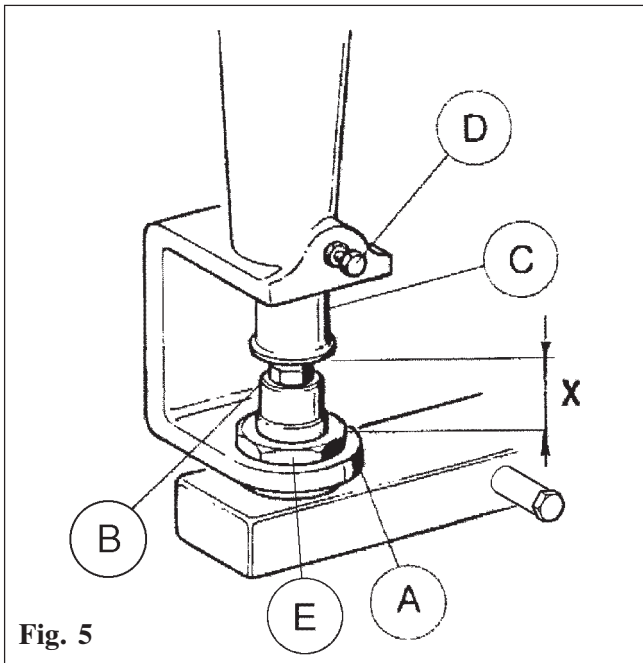

Fig. 5

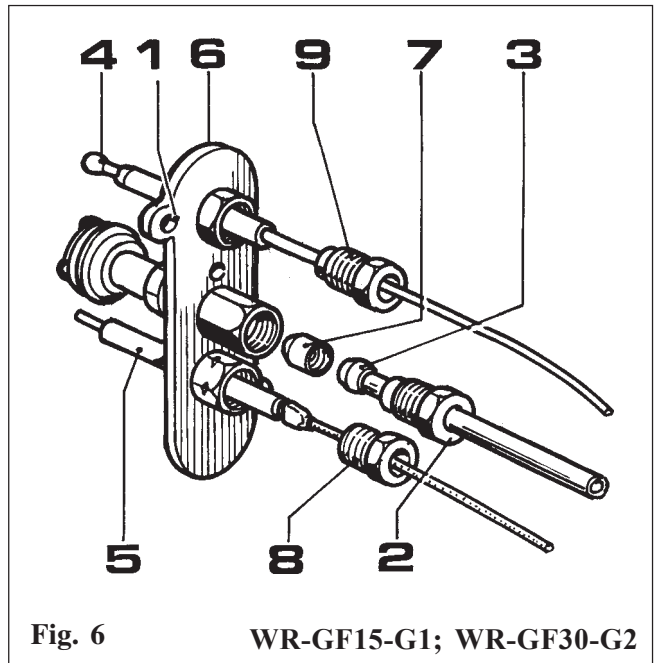

Fig. 6

WR-GF15-G1; WR-GF30-G2

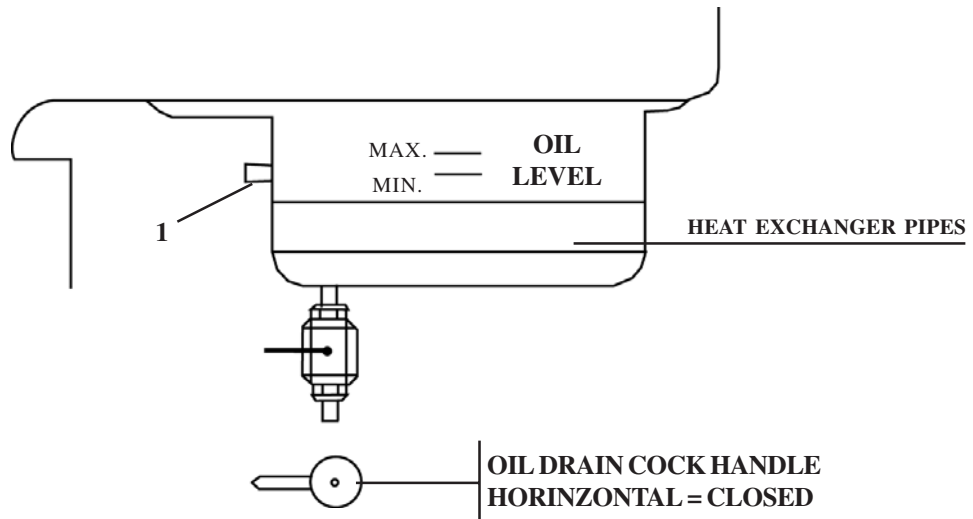

Fig. 8

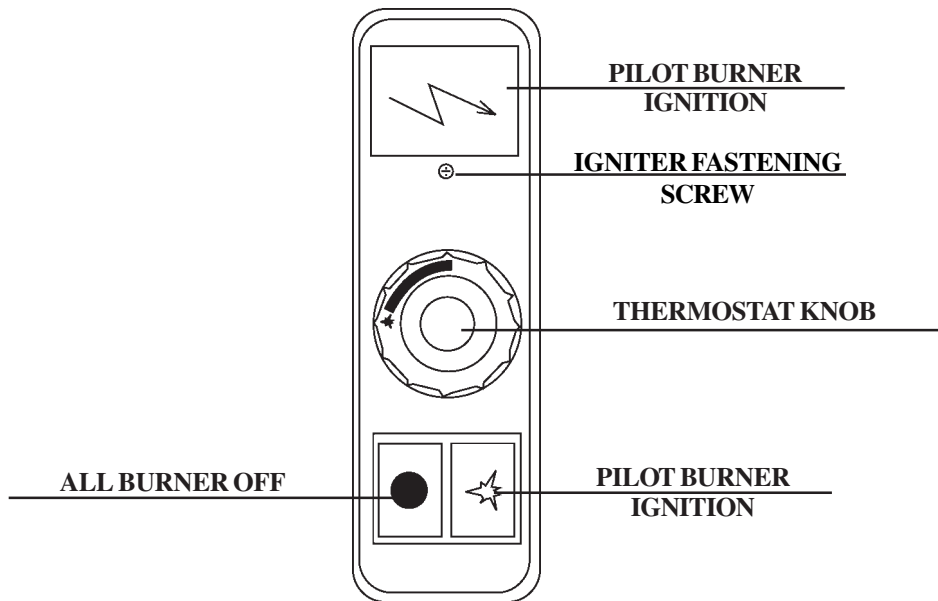

Fig. 9

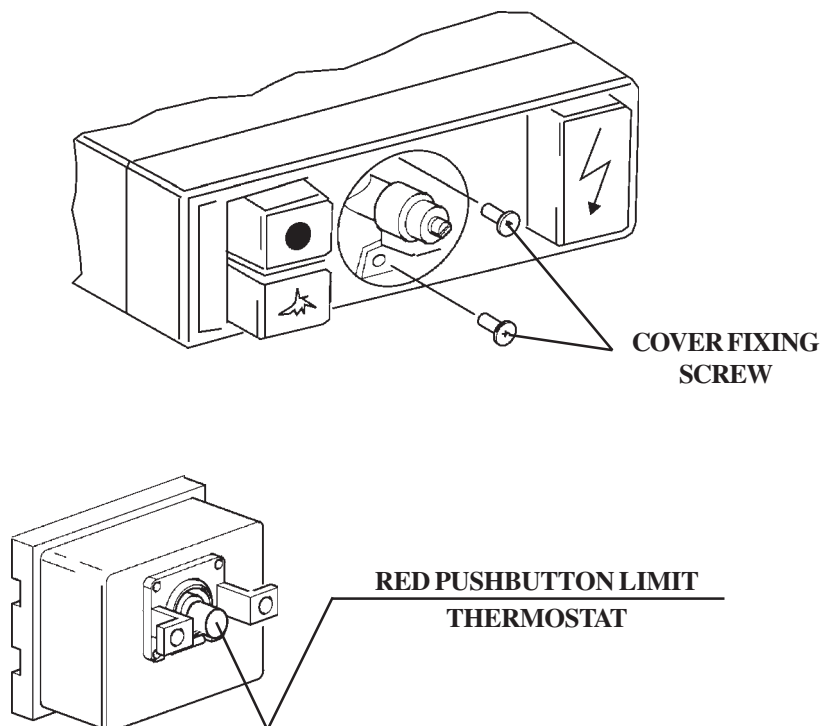

Fig. 10