



MOD : SP50M-2F-R2

Production code : SFM006P001-DI

05/2025

Instruction manual

Instructions translated from the original



This Use and Maintenance Handbook is entrusted to users of BLOCKSYSTEM SF R290, to instruct the technicians responsible for maintenance and operators. The instructions, drawings, tables and any other contents of this handbook are of a confidential technical nature and cannot be reproduced and/or divulged, completely or in part, without the specific written authorisation of It is explicitly forbidden for technicians and operators responsible for maintenance and operations to diffuse the information contained in this handbook or use it for purposes other than those closely linked to the good conservation of the BLOCKSYSTEM SF R290, its use and maintenance.

Cannot be held responsible or prosecuted for damages caused by the incorrect use of the documentation. To avoid incorrect operations which could be dangerous to people, it is important to read and understand all the documentation supplied with the BLOCKSYSTEM SF R290.



DANGER! Anyone who uses this machine is obliged to read these instructions for their own safety.



Contents

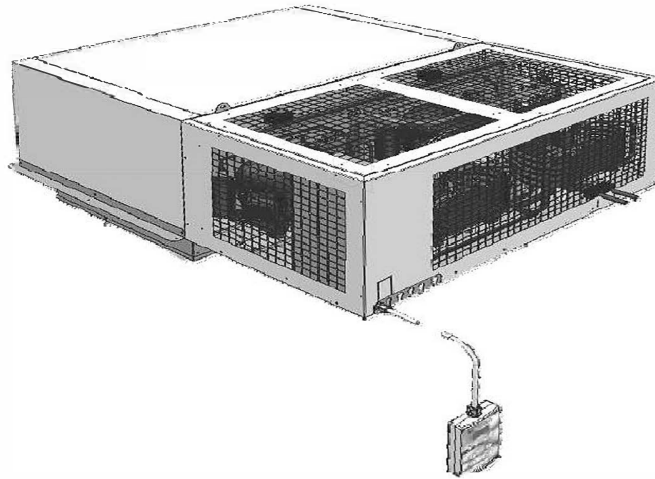

1 General information

- 1.1 General information
- 1.2 Property of information
- 1.3 Contents of use and maintenance handbook
- 1.4 Convention and definitions
- 1.5 Warranty
- 1.6 Support

2 Machine description

3 Safety and technical data

- 3.1 Safety general information
- 3.2 Protection device and solutions
- 3.3 Residual risk Warnings
- 3.4 Safety signs
- 3.5 Work Area and position of the operator
- 3.6 Noise and vibration indications
- 3.7 Proper and improper use of the machine
- 3.8 General warnings and behavioural norms
- 3.9 Machine data and technical features
- 3.10 Technical data and overall dimensions

4 Transport and installation

- 4.1 General information
- 4.2 Transportation and movement
- 4.3 Installation
- 4.4 Storage

5 Maintenance and demolition

- 5.1 General maintenance information
- 5.2 Cleaning and maintenance
- 5.3 Out of service, dismantling and demolition

6 Faults search

1. General Information

1.1 General Information

This Use and Maintenance Handbook is an integral part of the BLOCKSYSTEM SF R290 (identified, in this document, with the term MACHINE) manufactured by; for this reason, it must accompany the MACHINE if transferred to a new user or owner. This handbook must be carefully stored and protected from any agents which could cause its deterioration, for the entire lifecycle of the machine.

This handbook was drafted for the purpose of providing operators and technicians responsible for the maintenance of the machine with the essential information and instructions to correctly operate the machine in safe conditions.



ATTENTION: Please keep this manual in a safe and accessible place for use as an immediate reference by any operator or engineer.

This handbook contains all the data and information necessary for preliminary training of staff responsible for managing the MACHINE correctly; for this purpose, its use is compulsory.



DANGER: for clarity, some illustrations in this handbook show the machine or its components when opened or dismantled; it is however forbidden to use the machine in such conditions.

Even though all the attention notes and warnings for correct use of the MACHINE by the operators have been highlighted or to enable staff responsible for maintenance to intervene correctly, this handbook assumes that, in the environments in which the MACHINE is installed, all norms in force are complied with in relation to safety and hygiene in the workplace matters and that staff responsible for operation and maintenance have a level of training that allows them to correctly interpret the information reported.



NOTE: the user can request a copy of this document (for example, in case of damage to the original document) by making a written request to the Manufacturer's Technical Office (see Paragraph 1.6.1 – Request for Support in this chapter), making a commitment, in any case, to replace the damaged copy.

1.2 Property of information

This Use and Maintenance Handbook contains confidential information.

All rights reserved.

This handbook cannot be reproduced or photocopied, all or in part, without the prior, written consent of the manufacturer. Use of this documentation material is only permitted to the client to whom the handbook was provided with the machine and only for purposes of installation, use and maintenance of the machine to which the handbook refers.

The manufacturer declares that the information contained in this handbook complies with the technical and safety specifications of the machine to which the handbook refers. The drawings, diagrams and technical data reported are updated on the date of publication of this document and are exclusively valid for the machine to which they are attached.

The manufacturer reserves the right to make changes or improvements without prior notice to this documentation material.

The manufacturer does not assume any responsibility for direct or indirect damage to persons, property or domestic animals as a result of use of this documentation material or the machine in conditions other than those planned.

1.3 Contents of the Use and Maintenance Handbook

This Maintenance Handbook is for use by operators and technicians to allow them to understand and correctly use the MACHINE.

This handbook, in fact, other than a functional description of the MACHINE and its main parts, also contains the instructions and indications to:

- transport and install the MACHINE correctly;
- correctly use the MACHINE;
- conduct correct cleaning, regulation and maintenance of the MACHINE;
- pay attention to the fundamental safety and accident prevention regulations.

The aforementioned staff will therefore have the chance to understand the potential of the MACHINE and the problems that may arise during its management.

It is necessary to carefully read all the chapters to understand the instructions provided in this handbook and to operate the MACHINE; for subsequent, easy searches of the contents, refer to Table 1, containing a description of the topics covered in the chapters.

Table 1 – Layout of Use and Maintenance Handbook

CHAPTER	CONTENTS	RECIPIENTS
Chapter 1 General Information	<ul style="list-style-type: none"> ➤ Description of this use and maintenance handbook, of its layout and the conventions used; ➤ definition of the terms used; ➤ definition of the relationship between the manufactures and the purchaser/user (in terms of the warranty and support conditions). 	All staff using the MACHINE.
Chapter 2 Machine description	<ul style="list-style-type: none"> ➤ Description of the MACHINE and its functioning. 	All staff using the MACHINE.
Chapter 3 Safety and Technical Data	<ul style="list-style-type: none"> ➤ Presentation of general indications for the MACHINE, on the solutions implemented to protect operator staff, on generic warnings to comply with to correctly, use the machine and the residual risks present during the phases of the life cycle of the MACHINE; ➤ presentation of the main technical data concerning the MACHINE. 	All staff using the MACHINE (in particular, the mechanic and electric maintenance workers and the personnel appointed to its handling).
Chapter 4 Transportation and Installation	<ul style="list-style-type: none"> ➤ Description of the lifting and transportation modes of the MACHINE; ➤ description of the modes of connection to the power supply and of the appliances; ➤ description of the storage modes of the MACHINE. 	All staff using the machine (in particular the mechanic and electric maintenance workers, the technicians of the Producer, and the personnel appointed to handling.)

CHAPTER	CONTENTS	RECIPIENTS
Chapter 5 Maintenance and Demolition	<ul style="list-style-type: none"> ➤ Description of the verification and control procedures of the parts and the components of the MACHINE (in particular, the parts most subject to wear out); ➤ description of the procedures that allow the appointed personnel to perform the cleaning of the MACHINE; ➤ presentation of the indications to perform the dismantling, demolition, and disposal of the MACHINE. 	All staff using the machine (in particular the mechanic and electric maintenance workers, the technicians of the Producer, and the personnel appointed to handling.)
Chapter 6 faults search	<ul style="list-style-type: none"> ➤ List of the possible malfunctions of the machine and the relative solutions. 	All staff using the MACHINE.
Chapter 7 Attachments	<ul style="list-style-type: none"> ➤ Indications for the retrieval of the: <ul style="list-style-type: none"> ▪ technical sheet of the MACHINE, ▪ refrigerant diagram, 	All staff using the MACHINE.

1.4. Convention and Definitions

1.4.1. General Information

The Use and Maintenance Handbook of the MACHINE was divided into chapters to enable, for each phase of the MACHINE life (transport, installation, use, regulation, maintenance and decommissioning), easy availability of relative necessary information for the user of the MACHINE.

All the documentation relating to the MACHINE was drafted by developing the topics indicated by the Machinery Directive (2006/42/EC), PED Directive (97/23/CE) and the safety norms in force; therefore, the *complete reading of all the relative material* is indispensable to obtain the best performance from the MACHINE and ensure maximum duration of all its units.

The configuration of certain units or devices described or shown in the documents can differ from that in the MACHINE in the specific preparation according to particular requirements or safety norms; in this case, certain descriptions, references or procedures recommended can be generic in order to maintain their efficiency. Drawings mentioned or photographs are provided for example purposes as a reference for easy comprehension of the text.

1.4.2. Term conventions

MACHINE: the term used in this Use and Maintenance Handbook to indicate the BLOCKSYSTEM SF R290 .IPD: the acronym indicates Individual Protection Device/s.

1.4.3. Definitions

DANGER ZONE Any ZONE inside or near the MACHINE in which the presence of an exposed person composes a risk to the safety and health of that person.

USER Any PERSON (business person/company) adequately using the MACHINE or that assigns its use or operations connected to use to trained people.

EXPOSED PERSON Any PERSON located inside or partly in the danger zone or near these zones.

OPERATOR Staff, generally without specific skills, that conduct the operations necessary to operate the MACHINE and clean the MACHINE and the place in which it is installed; if necessary, the operator can conduct simple regulation and restore of functioning operations on the MACHINE.

MECHANICAL MAINTENANCE PERSON QUALIFIED TECHNICIAN who can intervene on any mechanical unit to regulate or repair it and conduct the necessary maintenance operations. The mechanical maintenance person is not enabled to conduct intervention on the electrical systems when voltage is present.

ELECTRICAL MAINTENANCE PERSON QUALIFIED TECHNICIAN responsible for all electrical intervention (regulation, maintenance and repairs) and, when necessary, works with voltage present inside the electrical cabinets and the shunt boxes.

MOVEMENT STAFF QUALIFIED STAFF that perform the tasks of moving the MACHINE or the materials used if the operation requires the use of lifting devices.

MANUFACTURER TECHNICIAN QUALIFIED TECHNICIAN made available by the manufacturer of the MACHINE to conduct complex operations in particular situations or, however, when agreed with the user.

1.4.4. Individual Protection Devices and Behaviour Norms

For each of the operations described in this handbook, the individual protection devices were indicated for responsible staff which must be used (if necessary, in addition to those staff must wear when installing the MACHINE) and the behaviour norms that enable operator safety to be safeguarded.



NOTE:

Paragraph 3.8 – General Warnings and Behaviour Norms in Chapter 3 – Safety and Technical Data in particular reports a series of general recommendations to comply with to avoid risk conditions for people or damage to the machine.

1.4.5. Machine status

The status of the MACHINE is the feature that describes both the functioning mode (for example, on and off) and the safety conditions present (for example, guards included, guards excluded and electrical power sectioning).

1.4.6. Typographic conventions

The graphical settings of this Use and Maintenance Handbook enable *easy recognition of contents*; in this optic, for example, the instructions are associated with lists, indicated as follows:

➤ this symbol identifies a generic pointed list or a pointed list formed by simple actions (the order in which the actions are presented is not binding, but recommended);

1. in this way an explanatory numbered list identifies a complex procedure (the order in which the actions are presented is binding to correctly and safely conduct the intervention in question).

Text in *Italics* is used, in particular for:

➤ cross references; cross references used in this handbook are expressed in the following format: “Paragraph/Figure/Table” with the number and, generally, the specification of the “Chapter” with the number and relative name (when not specified it is assumed the paragraph, table or figure belongs to the current chapter);

➤ technical and specialist terms, the first time they appear in the text;

➤ foreign terms not commonly used (they too, usually only the first time they appear in the text).

Bold text is used to highlight words, sentences or parts of procedures.

In the description of the MACHINE, its components, its use and maintenance, explanatory figures of the portion in question are used and these identify the specific points of interest, with the following notation:

number Symbolic representation of a command or signalling device (for example, buttons, selectors or indicator lights).

letter or number Symbolic representation of a part of the MACHINE.

Furthermore, to guarantee more in-depth knowledge of the MACHINE and the indications for its correct and safe use, the text of this Use and Maintenance Handbook comes with indications that complete it, providing additional news, indispensable attention or danger notes that are particularly significant to consider; the following notation is used in relation to this:



NOTE: indicates the notes, the warnings, the suggestions and other points the reader should pay attention to or complete the explanation with further news.



ATTENTION: indicates situations or operations where there is a valid possibility of causing damage to the machine, the equipment connected to it or the environment.



DANGER: indicates situations or operations which must be followed or information to which particular attention must be paid to avoid harming people.

GRAPHIC SYMBOLOLOGY USED TO INDICATE THE NEED FOR INDIVIDUAL PROTECTION DEVICES

This paragraph indicates the graphic symbols used in this handbook to indicate the need to wear certain IPD.



Indicates the need to use suitable head protection to conduct the operation described.



Indicates the need to use suitable protective gloves to conduct the operation described (possibly dielectric to conduct electrical system intervention).



Indicates the need to use suitable protective clothing to conduct the operation described.



Indicates the need to use suitable safety footwear to conduct the operation described.



Indicates the need to use suitable protective goggles to conduct the operation described.

1.5. Warranty

1.5.1. General Conditions

The manufacturer, guarantees the BLOCKSYSTEM SF R290 and its equipment manufactured by the same manufacturer as being free of material and manufacturing defects for a period agreed and stipulated in the sales contract of the MACHINE.

1.5.2. Parts excluded from warranty

The warranty excludes pieces that wear and all consumable tools and materials possibly supplied by the manufacturer with the MACHINE.

1.5.3. Responsibility of the User

The client is responsible for:

- electrical system set-up;
- consumable tools and materials.

1.5.4. Operations causing warranty invalidity

Any attempt to dismantle, modify or tamper with a MACHINE component by the user or by unauthorised staff leads to the warranty becoming invalid and removes the manufacturer from any responsibility regarding possible damage to persons or property deriving from such tampering.

The manufacturer is also removed from possible responsibility and the warranty is invalid for the MACHINE in the following cases:

- unplanned use of the MACHINE (see Paragraph 3.6 – Proper and improper use of the machine Chapter 3 – Safety and Technical Data);
- use contrary to requisites in norms in force in the country of use;
- installing the MACHINE in conditions other than those specified in Chapter 4 – Transport and Installation;
- connections non-conforming to specifications reported in Chapter 4 – Transport and Installation;
- use of work equipment other than those specified in Chapter 5 – Maintenance and Demolition;
- total or partial non-compliance with the instructions reported in this handbook;
- no or incorrect maintenance;
- use of non-original parts or those not specified by the manufacturer.

1.6. Support

Regarding maximum use of the performance provided by the MACHINE and the extraordinary maintenance operations, this handbook does not replace the experience of the installers, users or maintenance staff that is trained and qualified.

On the subject, the Technical Support Service provides:

- telephone support on the features and simplest interventions to conduct on the MACHINE ;
- sending of documentation material;



ATTENTION:

in case of doubt on the correct interpretation of instructions in this Use and Maintenance Handbook, contact the Technical Support Service (as indicated below) to obtain the NECESSARY clarifications.

1.6.1. Intervention Support Requests

To contact the Technical Support Service contact the:

During the requests for support, specify the name, model and registration of the machine.

2. Machine description

The machine represents a refrigerating system made up of a condensing unit (outside the cold room), an evaporating unit (inside the cold room), and an electronic control board placed within the condensing unit. The refrigerant fluid follows the modes of the compression refrigeration cycle. The machine can be equipped with one or two refrigerating cycle and the condenser can be at air or water. The machine is equipped with a hot-gas defrosting system controlled by the electronic control unit. The defrost is automatic and takes place with a preset frequency that can be modified by the user; it can also be enabled manually via the specific control.

This solution allows the customer to have a product that is easy to use and install and which is incredibly versatile. The use of state of the art technological solutions has allowed us to optimize the machine's overall dimensions, improving its installation procedures, especially on cold rooms with reduced dimensions.

All refrigerant containing parts are made tight by welding, brazing or a similar permanent connection, and our factory leak test procedure ensures a leakage rate in accordance with current legislation. Under such conditions it is possible to define the machine a "hermetically sealed system" as per Section 3.1.7 of EN378-1 standard.

3. Safety and Technical Data

3.1. Safety General Information

3.1.1. Engineering Criteria

For the machine design, the principles and concepts introduced in the relevant paragraphs of the norms indicated in Table 2 were implemented.

Table 2 – Main norms used in the machine design.

NORM	TITLE
UNI EN ISO 12100-1: 2009	Safety of the machinery - Key concepts, general engineering principles - Part 1: Base terminology, methodology
UNI EN ISO 12100-2: 2009	Safety of the machinery - Key concepts, general engineering principles - Part 2: Technical principles
UNI EN ISO 14121-1: 2007	Safety of the machinery - Evaluation of the risks - Part 1: principles
UNI EN ISO 13857: 2008	Safety of the machinery - Safety distances to prevent upper and lower limbs from reaching dangerous areas
UNI EN 953: 2009	Safety of the machinery - Guards - General requisites for the engineering and the construction of the fixed and mobile guards
UNI EN 1127-1: 2008	Explosive atmosphere – Prevention of explosion and protection from explosion- Part 1 : Fundamental concept and methodology
CEI EN 60204-1: 2006	Machinery safety – Electrical equipment on the machine - Part 1: General rules:
CEI EN 60335-1: 2008	Safety of the electrical equipment intended for domestic use and other similar equipment - Part 1: General norms

The compliance of the paragraphs to the aforementioned norms has enabled risks to be eliminated or reduced as much as possible, both during normal functioning and during regulation and maintenance operations, for the entire lifecycle of the machine.

The components used were carefully chosen among those available on the market and the materials composing the machine (and the machine accessory tools) present no risks to personal health and safety. All the parts provided by third parties are CE marked (when planned) and comply with the relevant reference directives. All the details were closely controlled in compliance with the qualitative standards prescribed by the laws in force.

For the machine, the warning and protection measures were also implemented that are necessary to confront residual risks (see Paragraph 3.3 – Residual Risk Warnings on this).

3.2. Protection Devices and Solutions

3.2.1. Passive Safety Devices

The machine includes implemented devices and construction solutions as described below.

- Fastened guards, on all sides of the machine, which enclose the entire body of the machine.
- Fastened guards in metal or plastic mesh over the mobile units.
- Safety signs corresponding to the machine protections.

3.3. Residual Risk Warnings

To avoid all dangerous conditions for people or damage to the machine caused by residual risks, i.e. those risks that persist despite all the devices implemented, or potential risks that are not obvious, the manufacturer recommends the operators, maintenance staff and all staff working on the machine scrupulously follow the warnings on the following pages.



ATTENTION:

always comply with the notifications and instructions on the plates applied to the machine and operate exclusively based on the instructions provided in this handbook (for example those reported in Paragraph 3.8 – General Warnings and Behaviour Norms).

3.3.1. Lifting and Transportation

3.3.1.1. Residual Risks During Lifting and Transport Phases

During the lifting and transport phases, risks are present related to:

- operations on the machine by staff that is unqualified, untrained, uninformed or not correctly equipped.
- wrong choice or wrong use of transport and movement vehicles (for example, forklift or hoist) for the machine;
- crushing of operators responsible for movement;
- loss of load stability during the operations in question;
- projection of mobile parts of the machine that cannot be adequately removed or fastened;
- knocking of parts or machine components with people or property due to sudden movements of the machine or incorrect behaviour of the employees conducting the operation;
- knocking or falling of machine components, damaging the machine and the relative protections;
- possible unhealthy or excessively forced movements by transport and movement operators of the machine components.

3.3.1.2. Necessary Individual Protection Devices



3.3.1.3. Attention Warnings During Lifting and Transport Phases

During the lifting and transport phases, it is necessary to follow the attention warnings in this paragraph.

- Only appoint specialist and trained staff for these operations for machinery movement operations that are capable of choosing and using the lifting and transport vehicles in a safe manner most appropriate for the situation (for example a crane or hoist).
- Check and, if necessary, ensure that all the parts capable of moving are correctly fastened (or, if planned, removed and reassembled when the operation is complete).
- Do not lift, for any reason, the various parts of the machine by grabbing them by non-structural elements (for example, cables or sheaths).
- Ensure there are no people near the zone where the lifting, movement and unloading operations take place and always keep a safe distance.
- Always give warning of the start of manoeuvres.
- Do not transit under suspended loads.
- Do not carry anyone on the loads.

3.3.2. Installation and Connection

3.3.2.1. Risks During Installation and Connection Phases

During the installation and connection phases, risks are present related to:

- operations on the machine by staff that is unqualified, untrained, uninformed or not correctly equipped.
- contact with electrically powered elements;
- knocking or crushing by moved machine components;
- tripping or falling over electrical power connections;
- machine damage during the installation and connection phases.

3.3.2.2. Necessary Individual Protection Devices



3.3.2.3. Signs Present

The machine is supplied with specific danger and forbidden signs; see *Paragraph 3. 4 – Safety Signs*.

3.3.2.4. Attention Warnings During Installation and Connection Phases

During the installation and connection phases, it is necessary to follow the attention warnings in this paragraph.

- Follow the instructions relating to safety reported in *Paragraph 3.3.1 – Lifting and Transport* during the necessary movement operations of the machine components.
- Use the auxiliary equipment and, however, any other machinery or equipment (electrical or pneumatic) only having understood the instructions reported in the relative Use and Maintenance Handbook or after specific and formal training.
- Choose an installation location which:
 - includes sufficient space for normal use and maintenance of the machine,
 - enables the correct connections necessary for machine functioning,
- In relation to electrical energy, the earthing system connection must be connected **before any other connection** to the electrical mains line.
- Protect connection tubing to energy sources using adequate rigid sheathing or cable passages.
- Conduct the intervention requested using standardised work tools (ladders, various tools) and pay maximum attention to elements that could cause tripping or cause cuts and trauma.
- The operational settings of the machine cannot be dealt with until the machine is inspected: the presence of possible assembly or installation errors could in fact lead to serious accidents for the operators responsible for the operations.
- Before proceeding with the inspection and the first functioning of the machine, check its parts do not present any physical damage due to knocks, tears or abrasion and that all the connections present were correctly conducted, with no possibility of disconnection.

3.3.3. Machine use

3.3.3.1. Residual Risks during Machine Use Phase

During machine use the following risks are present due to:

- use of the machine by staff that is unqualified, untrained, uninformed or not correctly equipped.
- contact with electrically powered parts;

3.3.3.2. Necessary Individual Protection Devices



3.3.3.3. Signs Present

The machine is supplied with specific danger and forbidden signs; see *Paragraph 3. 4 – Safety Signs*.

3.3.3.4. Attention warnings during machine use

During use of the machine, it is necessary to follow the attention warnings in this paragraph.

- Only use the machine if all the safety protection devices are intact.
- Do not remove, for any reason, the safety devices and protections installed.
- Comply with all the safety and danger signs affixed to the machine.
- Ensure all the safety and danger signs affixed to the machine are legible.
- Wear all the IPD necessary, regularly checking their integrity (immediately signal any IDP that are no longer capable of conducting the specific task they were assigned for).
- Do not intervene on the machine without having fully and carefully read this handbook.
- Use the auxiliary equipment and, however, any other machinery or equipment (electrical or pneumatic) only having understood the instructions reported in the relative Use and Maintenance Handbook or after specific and formal training.
- Immediately signal functioning anomaly situations.
- Do not conduct any intervention (including cleaning) on movement units or hot surfaces.
- Do not conduct unpermitted operations on the machine (refer to the instructions reported in this handbook).
- Do not use the machine when under the influence of medicine or beverages that can slow your reflexes.

3.3.4. Maintenance and Demolition

3.3.4.1. Risks During Maintenance and Demolition Phases

During the maintenance and demolition phases, risks are present related to:

- operations on the machine by staff that is unqualified, untrained, uninformed or not correctly equipped.
- contact with powered electrical parts;
- knocking or crushing by moved machine components;
- contact with hot elements on the machine or relative equipment;
- contact with the refrigerant.

3.3.4.2. Necessary Individual Protection Devices



3.3.4.3. Signs Present

The machine is supplied with specific danger and forbidden signs; see *Paragraph 3. 4 – Safety Signs*.

3.3.4.4. Attention warnings during maintenance and demolition Phases





During the maintenance and demolition phases, it is necessary to follow the attention warnings in this paragraph.





- Conduct the interventions requested using the standardised work tools (ladders, various tools) and always wearing the necessary IPD.
- The implementation of maintenance and demolition interventions must be performed by qualified, specifically trained staff.
- Check that the power supplies are adequately sectioned and that nobody can reactivate them prior to concluding the requested interventions (use of locks, adequate signs and consolidated work procedures); also check that any residual energy was discharged before conducting the intervention.
- Operate, as much as possible, on the machine and the tubing only after emptying it and before proceeding to restarting, guaranteeing adequate cleaning of the system.
- Obtain the necessary work permits and check all the preparation procedures of the machine for maintenance operations are correctly conducted.
- Use the auxiliary equipment and, however, any other machinery or equipment (electrical or pneumatic) only having understood the instructions reported in the relative Use and Maintenance Handbook or after specific and formal training.
- Do not use, for any reason, petrol, solvents or inflammable fluids to clean parts, but use commercial, approved detergent that is inflammable and non-toxic.
- Do not make changes, transformations or applications to the machine that could prejudice safety, without having obtained written authorisation from the manufacturer.
- Before restarting the machine, check that all the safety devices of the machine were restored.

3.4. Safety signs

Signaling labels are present on the machine, which are indicated in *Table 3*.

Table 3 – Description of the signaling labels present on the machine.

	LABEL	DESCRIPTION
A		This label indicates that it is forbidden to remove the safety devices and protections installed on the machine; it is usually accompanied by the explicatory writing: DO NOT REMOVE THE PROTECTION DEVICES.
B		This label indicates that it is forbidden to perform any intervention (including lubrication and cleaning) in proximity of moving parts; it is usually accompanied by the explicatory writing: DON NOT REPAIR OR REGULATE DURING MOTION.
C		This label warns about the danger due to the presence of mobile parts in proximity of the area in which the machine is positioned.
D		This label warns about the danger due to the presence of warm surfaces in proximity of the area in which the machine is positioned.

E		This label warns about the danger to the presence of refrigerant fluid fired (only for model with R290).
F		This label warns about the danger due to the presence of elements under voltage in proximity of the area in which the machine is positioned.
G		This label warns about the obligation to read the manual for the installation
H		Warning to the sharp parts during condenser cleaning

3.5. Work Area and Position of the Operator

The machine functions automatically requesting the intervention of the operator corresponding to the control and command software only to manually start and stop and for functioning programming. The operator's work area therefore exclusively corresponds to the control panel on the machine.

3.6. Noise and Vibration Indications

3.6.1. Noise

BLOCKSYSTEM SF R290 were designed and manufactured to reduce the noise emitted during normal functioning to a minimum. The level of mass acoustic pressure A generated by BLOCKSYSTEM SF R290 and measured, following the criteria set by the norms in force, during functioning is less than 70 dB (A).

3.6.2. Vibrations

In use conditions in compliance with the instructions supplied by the manufacturer in this handbook, the vibrations were not such to create dangerous situations. The operator however, if vibrations occur, should immediately stop the machine and signal the phenomenon to the manufacturer's support service.

3.7. Proper and Improper Use of the Machine

The machine has been designed and built for the **sole** industrial and commercial refrigeration in permanent premises. The Block system SF R 290 is exclusively designed to be installed on a horizontal wall (ceiling mount).

The MACHINE can **only** use the refrigerant gas for which it has been designed, which is R290.

The machine has been designed and built to operate in premises **without a potentially explosive atmosphere**.

The machine must be adequately protected against atmospheric agents.

It is a sound cautionary norm to place powder extinguishers near the machine. To prevent the possibility of a fire outbreak, the machine must be kept clean of pieces of plastic, oils, solvents, paper, and rags.

Use of the machine for different operations could cause damages to persons or to the machine itself, and such operations are therefore considered **improper uses** for which the Manufacturer does not deem itself responsible.



WARNING:

in case of a different destination of use, it is indispensable to consult the Manufacturer's Technical Office in advance.

3.8. General Warnings and Behavioural Norms

To avoid any risky conditions to people or damage to the machine, we recommend you scrupulously follow the general warnings and behavioural norms reported here.



DANGER:

the manufacturer declines all responsibility for any damage to property and/or persons deriving from improper interventions conducted by unqualified, untrained or unauthorised staff.

- ▶ The operators responsible for machine management must be adequately trained to use it at its best and without risk and must operate in a comfortable environment that guarantees the best safety and hygiene conditions possible.

**DANGER:**

prevent the machine being used by unauthorised staff or untrained staff without supervision: in fact, before starting work, each operator must be perfectly aware of the position and functioning of all the controls and features of the machine. Furthermore, the operator must have read this handbook ENTIRELY.

- ▶ Before using the machine, ensure that any dangerous conditions to safety are adequately eliminated and that there are no operators present in the danger zones near the machine.
- ▶ Before using the machine, ensure all the guards are in place and that all safety devices are present and efficient.
- ▶ Warn supervisors of any functioning irregularities in the machine or any problems relating to the integrity of the machine protections.
- ▶ Carefully read the machine labels. Do not cover them for any reason and replace them immediately if damaged.
- ▶ Do not rest liquid containers on the machine.
- ▶ Consult this handbook on the safety specifications in force and the specific IPD to implement for personal safety; in particular, however, the staff responsible for the machine must wear suitable clothing, by avoiding or paying due attention to:
 - loose clothing,
 - wide sleeves,
 - ties or hanging scarves,
 - necklaces, bracelets and rings.
- ▶ Staff responsible for maintenance of the machine must be aware of all the procedures reported in *Chapter 5 – Maintenance and Demolition* and be adequately prepared technically to correctly interpret the instructions and diagrams in this handbook and to intervene on the machine.
- ▶ The area where the maintenance operations take place must always be clean, dry and with suitable equipment always available and efficient.
- ▶ The work area must never be occupied in such a manner to interfere with the free movement of the operator. In case of emergency, immediate access to the machine must be guaranteed for responsible staff.
- ▶ In the aforementioned area, access to people who are not directly responsible for machine functioning is forbidden, to avoid danger due to distraction or negligence during machine intervention.
- ▶ If intervention has to be conducted near the electrical components, work with dry hands and use dielectric gloves (working on electrical components with wet hands leads to almost certain danger of electrical shock).

**DANGER:**

you should ensure that before starting any type of machine intervention or corresponding to its components or accessory equipment to section power; if this is not possible, it is necessary to take measures to allow you to operate on the machine in safe conditions.

**DANGER:**

tampering or unauthorised replacement or one or more parts of the machine and use of accessories, tools or consumable materials other than those indicated by the manufacturer can generate danger of injury.

**ATTENTION:**

all the materials with environmental impact which must be eliminated after interventions or processes on the machine must be disposed of according to norms in force. If necessary, entrust specialist structures to dispose of them.

3.9. Machine Data and Technical features

3.9.1. Identification Plate

To identify the machine, a CE identification plate is affixed to it; the identification data reported on this plate must be notified to the manufacturer's offices on each request for intervention or to order spare parts. Specifically, the identification plate reports the following data:

- code,
- registration,
- ampere absorption (A),
- Watt absorption (W),
- refrigerant type,
- power voltage (Volt/Ph/Hz),
- maximum operating pressure PS HP (high pressure side) – PS LP (low pressure side),
- maximum operating temperature TS HP (high pressure side) – TS LP (low pressure side),
- overall class according to directive 97/23/ CE (PED).

REGISTRATION IDENTIFICATION

- figure 1 and 2 = last two figures of year of manufacture,
- figure 3 and 4 = week of year in which the machine was manufactured,
- figures 5, 6, 7 and 8 = progressive number.

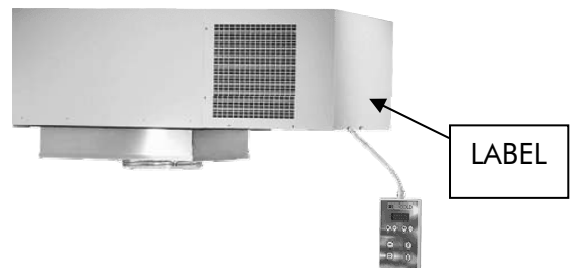

3.10. Technical Data and Overall Dimensions

The technical features of the machine are found in *Chapter 9 – Attachments* in this handbook.

4. Transport and Installation

4.1. General information

The installation and possible re-installation of the machine must be conducted directly by **qualified staff**.

Before proceeding to installing the machine, it is necessary to prepare the power supplies and utilities necessary for the correct functioning of the system, following the indications reported in this chapter and, if necessary, consulting the **manufacturer's** Technical Office in advance.



ATTENTION:

This product as sold complies with the 97/23CE (PED) standard and is marked with the relevant category. After purchase it is the responsibility of the owner to ensure that this equipment is regularly maintained continue its compliance up to the stage when it is finally decommissioned according to the relevant national law.



DANGER:

the manufacturer declines all responsibility for any damage to property and/or persons deriving from improper interventions conducted by unqualified, untrained or unauthorised staff.

4.1.1. Power and Utilities

The power supplies and utilities necessary (responsibility of the purchaser) for machine functioning exclusively consist in the supply of electrical energy.

Unless otherwise indicated, the **purchaser is responsible for:**

- the preparation of transport vehicles to transport the machine to the assembly or installation location;
- the preparation of equipment necessary for assembly and installation;
- the preparation of the installation location;
- the preparation of auxiliary vehicles and consumable materials (for example, non-flammable and non-corrosive detergents, materials and tools necessary for cleaning and cover).

4.2. Transportation and Movement

The indications contained in this paragraph must be complied with during the transport and movement phases of the machine, which can occur in the following situations:

- machine storage;
- assembly and first installation of the machine;
- de-installation and dismantling of the machine;
- moving and relocating the machine.



DANGER:

the manufacturer declines all responsibility for any damage to property and/or persons deriving from improper interventions conducted by unqualified, untrained or unauthorised staff.

To conduct the task in question, the following Individual Protection Devices are necessary:



During transport or movement of the machine, it is necessary to follow the warnings below:

- Check the lifting equipment is suitable for the weight and dimensions of the machine.
- Do not bang the structure or guards of the machine with equipment or otherwise.

4.2.1. Lifting



DANGER:

lifting operations must be conducted with the direct supervision of a qualified mechanical maintenance person or a manufacturer technician.

Lifting to move and subsequently position the machine can be performed using any adequate vehicle that guarantees its lifting in a safe and efficient manner (for example a hoist using a harness system for the machine). See Figure 2.

Figure 2 – Lifting the machine.

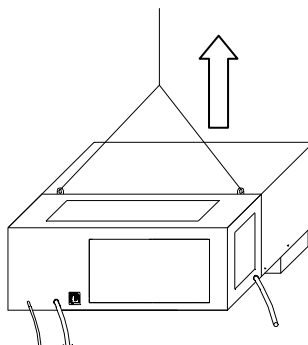

To correctly perform the lifting operations, follow the warnings reported below.

- Never use two lifting vehicles simultaneously.
- Never stay under suspended loads.
- If using steel ropes, always apply the end eye to the lifting hook.
- If using steel ropes, pay attention not to create sharp bends, i.e. with a bending radius lower than that of the rope end eyelets.
- Use adequately wide ropes, to enable the angle between the ropes and the horizon to always be over 45°.

4.2.2. Machine movement

For reduced distances, as in the case of transport to the assembly or storage locations of the machine, it is necessary to use lifting equipment (for example, forklift and hoists) suitable for the dimensions and weight of the machine.



ATTENTION: during all these operations follow the precautions necessary to avoid knocking and tipping over, moving the machine in a manner not to lose balance.



DANGER: ensure there are no unauthorised staff near the zone where the lifting, movement and unloading operations take place and always keep a safe distance.

4.3. Installation



DANGER: the manufacturer declines all responsibility for any damage to property and/or persons deriving from improper interventions conducted by unqualified, untrained or unauthorised staff.

To conduct the task in question, the following Individual Protection Devices are necessary:



The Blocksystem SF R 290 **must** be installed in locations where good recycling and exchange of air is guaranteed and **must** only be installed on vertical walls. The Blocksystem SF R 290 **must** be installed in locations where good recycling and exchange of air is guaranteed and **must** only be installed on horizontal walls (ceiling). For other installations, we recommend you contact the manufacturer. For positioning of a mono-condensing unit and the evaporator, comply with the minimum heights reported in Figure 3 *Figure 3 – Minimum compliance heights.*

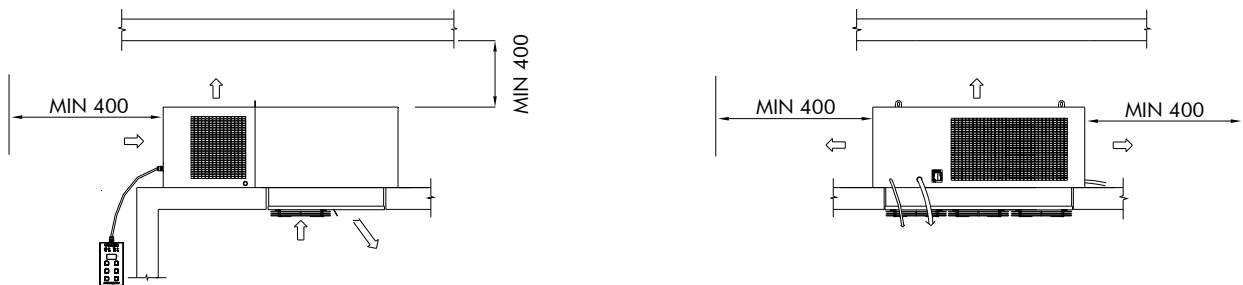

During installation, leave the machine sufficient space to conduct maintenance in safe conditions.

For correct functioning of the machine, we recommend the following thicknesses of the coldroom walls (polyurethane insulation): MBP and HBP coldroom insulation thickness **60 mm**; LBP coldroom insulation thickness **100 mm**.



DANGER: given that the machine contains refrigerant fluid R290, it is important that the premises where the machine is installed be properly ventilated.



DANGER: Do not install the equipment near external sources of heat/ignition, such as for example loose flames or hot surfaces (gas or electrical cookers, ovens, etc.), near electrical components (switches, relays, etc.), and near highly flammable materials"

4.3.1. SF Series Installation Method

To proceed to installation of the machine, implement the following procedure:

1. On the ceiling of the coldroom, based on the model, make a hole of suitable dimensions as indicated in the pages from Figure 5 of Chapter 7 at the end of the handbook.
2. Position the anti-condensate slab supplied along the perimeter of the hole.
3. Lift the machine with the hoist or another suitable vehicle in compliance with the lifting instructions in Figure 2.
4. Position the machine in the hole made in the ceiling of the coldroom and place the evaporating part in from outside.

5. Fasten the machine to the ceiling of the coldroom with self-threading screws using the two brackets and the screws supplied (Figure 4).
6. Seal the perimeter of the aluminium conveyor with silicon (suitable for use in the coldroom) to avoid infiltration of warm air inside the coldroom.
7. To connect the water-cooled condensers, the pipes used must not have a smaller diameter than those present on the Block system SF R 290, and you must follow the inlet and outlet indications. Install the water supply shut-off valve within reach of the operator.



ATTENTION: *never close the water shut-off valve while the device is in use.*

To improve the machine's performance and endurance, check that:

- ▶ the water's temperature ranges between 5°C and 20°C the condensing units are made for operating with well-water.
- ▶ the pressure of the water ranges between 1 and 5 bar.



ATTENTION: *the water pipelines must be protected against the low external temperatures.*

Figure 4 – Machine positioning in coldroom.

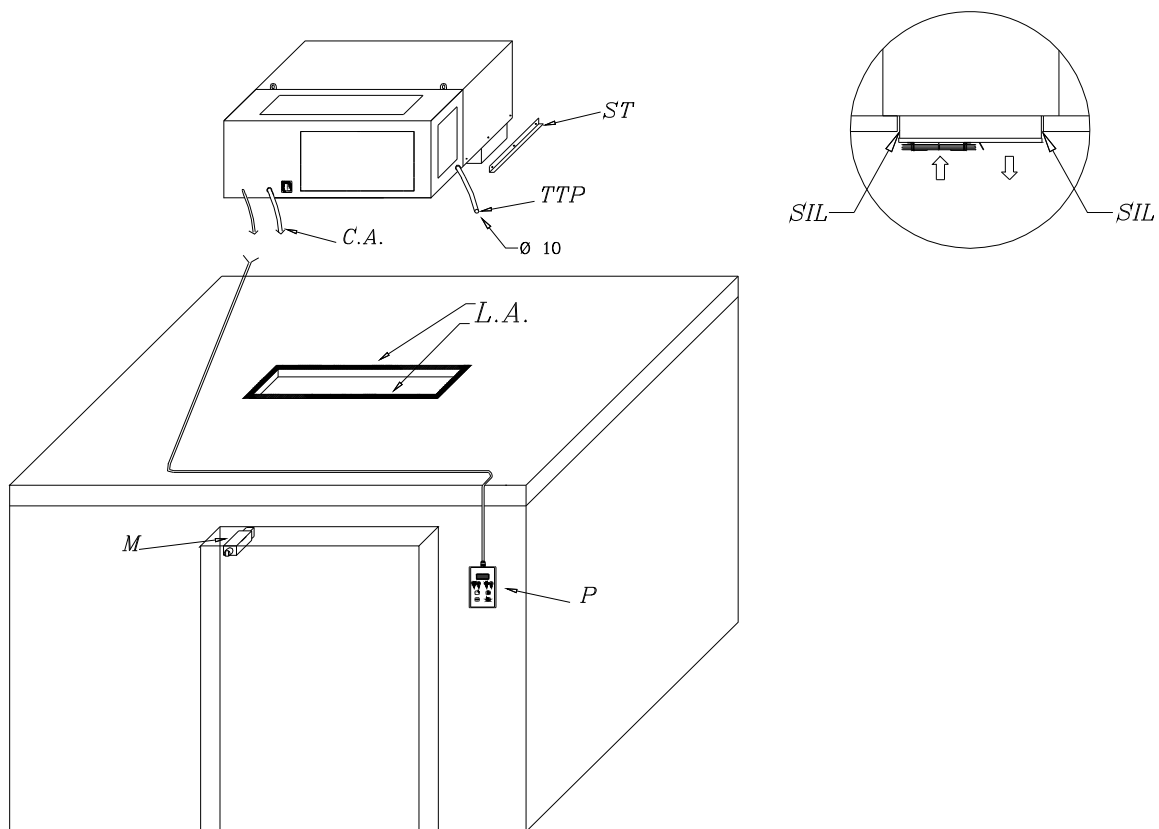

LEGENDA/LEGEND/LEGENDE/LEGENDE/LEYENDA

- TTP = Tubo di troppo pieno / Overflow water tube / Tuyau de trop plein / Abflußrohr / Rebosadero
- ST = Staffa di fissaggio / Fixing bracket / Etrier de serrage / Spannbügel / Grapas De Fijacion
- CA = Cavo alimentazione / Mains cable / Cable d'alimentation / Netzkabel / Cable alimentacion
- M = Micro-porta / Door micro-switch / Détecteur de porte / Tür-Kontakt Schalter / Micro-interruptor
- LA = Lastra anticondensa / Anticondensing plate / Plaques anticondensation / Kondens-Gegen Platte / Cinta anticondensation
- P = Pannello di comando / Control panel / Panneau de controre / Steuerungs-Paneel / Panel de mando
- SIL = Silicone / Silicon / Silicone / Sylicon / Silicona



ATTENTION: *the machine is equipped with a condensate water evaporation tank. We recommend you connect a rubber tube to the overflow tube to enable evacuation of water in case of functioning or use anomalies.*

4.3.2. Connection to electrical power mains

The electrical power supply (also in terms of voltage and frequency) supplied by the purchaser must be sufficient to correctly power the machine. Specifically the following instructions must be followed:

- ▶ The power cable must be laid out (no rolling or overlapping) in a position not exposed to possible knocks or tampering. It must not be near liquids, water or heat sources and must not be damaged (if so, replace it using qualified staff).
- ▶ Prepare a thermo-magnetic differential switch between the power line and the machine --- and ensure the voltage of the line corresponds to the voltage indicated on the plate (see label applied to the machine); tolerance permitted $\pm 10\%$ of nominal voltage.



ATTENTION: *the thermo-magnetic differential switch must be placed in the immediate vicinity of the machine to ensure it is well visible and reachable by the technician in case of maintenance.*

- ▶ It is necessary for the section of the power cable to be adequate to the power absorbed by the machine.



ATTENTION: *It is compulsory, pursuant to law, to connect the machine to an efficient earthing system. All responsibilities are declined for non-compliance with this directive; all responsibility is declined if the electrical system used for connection is not implemented according to laws in force.*

- ▶ Fasten the micro-door supplied on the door jamb of the coldroom which automatically causes, on opening, the lights in the coldroom to switch on and the compressor and fans to stop in the evaporator and condenser.



ATTENTION: *the micro-door cable must pass far from the cables with electrical power to avoid signal disturbances.*



ATTENTION: *installation of electrical components inside the cold room is entirely the care and responsibility of the installer. It is mandatory to only use material adapt to type risk, see regulations In force*

4.4. Storage

If necessary to store the machine for a period before installation (or following de-installation), we recommend you protect it adequately and store it in a suitable environment, with the following features:

- ▶ external surfaces resistant to atmospheric agents;
- ▶ protected against access to unauthorised people;
- ▶ with the following environmental conditions:
 - good ventilation;
 - room temperature between $-20\text{ }^{\circ}\text{C}$ and $+50\text{ }^{\circ}\text{C}$;
 - relative humidity of compressed air 30% and 80%;
 - possibly in dry, dust-free atmosphere.



ATTENTION: *do not remove any packaging possibly present for certain components of the machine and take adequate precautions to protect the exposed parts.*

4.4.1. De-installation

If the machine must be de-installed, proceed following the inverse order for installation reported in Paragraph 4.3 - Installation.



DANGER: *the manufacturer declines all responsibility for any damage to property and/or persons deriving from improper interventions conducted by unqualified, untrained or unauthorised staff.*

To conduct the task in question, the following Individual Protection Devices are necessary:



5. Maintenance and Demolition

5.1. General Maintenance Information

To guarantee maximum reliability to the machine and avoid dangerous conditions, scrupulously comply with the instructions and warnings reported in the following pages.



DANGER: *for safety reasons, all the maintenance operations reported in this chapter must only be conducted by qualified technicians that are specifically trained. The responsible technicians must also have all the tools and IDP necessary to operate safely.*



ATTENTION: *to always guarantee operators full efficiency and safety of the machine and prevent problems linked to deterioration of the safety measures or machine stoppages which can be taxing, it is necessary to implement efficient preventive maintenance, by planning interventions with planned intervals, with the purpose of renewing or replacing the normal wear parts and audit the general status of the mechanical and electrical components composing the machine (and its auxiliary equipment), thereby providing the instructions on possible extraordinary operations which may become necessary.*



ATTENTION: machines equipped with R290 refrigerant gases are supplied with factory sealed refrigerant circuit. It's strictly prohibited any work on it. For every problem on the refrigerating system, the machine should be returned to the manufacturer.

Before conducting any type of maintenance or cleaning intervention reported in this paragraph, it is necessary to section the machine from the electrical power supply; do so by removing the plug from the power socket.



DANGER: the manufacturer declines all responsibility for any damage to property and/or persons deriving from improper interventions conducted by unqualified, untrained, inadequately equipped or unauthorised staff.

5.1.1. Safety Signs

To conduct correct maintenance and cleaning operations, it is indispensable to take into consideration the indications reported below.

- ▶ During interventions, it is necessary to signal machine intervention using specific signs (these signs are positioned in such a manner to prevent any undesired intervention on the machine).
- ▶ During the interventions **only authorised staff** can access the work area.



ATTENTION: the maintenance and cleaning operations must only be conducted by expert and specialist staff that have read and understood all the indications reported in this Use and Maintenance Handbook.



DANGER: only dismantle the parts of the machine actually necessary to conduct the specific maintenance operation. Furthermore, before re-delivering the machine to operators, it is necessary to verify its integrity and functionality.

- ▶ All the materials with environmental impact which must be eliminated after maintenance interventions must be disposed of according to norms in force.



ATTENTION:: to dispose of materials with high environmental impact, if necessary, appoint specialist structures.

In any case, to conduct all the maintenance and cleaning operations reported below on the machine, the following Individual Protection Devices are necessary:



5.1.2. Verification of Material Availability

With an advance of at least **60 days** from the fixed date for maintenance interventions, conduct a detailed examination of the necessary material:

1. check the material is in the warehouse,
2. if necessary, ask the manufacturer's Technical Office for the missing pieces, at least **30 days** in advance.

5.2. Cleaning and maintenance



DANGER: the manufacturer declines all responsibility for any damage to property and/or persons deriving from incorrect or incomplete maintenance.



DANGER: before conducting any planned ordinary maintenance interventions, ensure the machine is sectioned from the power supply; also wait for any hot surfaces to cool.



ATTENTION: in case of replacement of machine components, they must be replaced with identical and original components.



ATTENTION: Any measures taken to braze on a product category risk PED ≥ 1 , must be conducted by qualified professionals.

5.2.1. Interventions and relevant frequency

- ▶ Visually check the entire refrigerating circuit, even inside the machines, to search for refrigerant leaks, which are also announced by traces of lubricating oil. Promptly intervene and examine in further depth if in doubt. Check for refrigerant gas leaks every 6 months.
If you uncover leakage, you must immediately intervene and check again **within 30 days** to make sure that the repair was successful.
- ▶ Check, **every four months**, regular flow of the refrigerant through the sight-glass present on the liquid line.

- ▶ Check, **every four months**, the oil level through the specific sight-glass (where included) placed on the housing of the compressor.
- ▶ Check, **every four months**, the noise level of the compressor. This operation must be performed with caution, since it requires that the system be working; check for the presence of clicking sounds or vibrations, which may be a symptom of breakage or of excessive mechanical play between the moving parts.
- ▶ **Regularly** check that the condensed water discharge is not clogged and that the water discharge coil is efficient (where included).
- ▶ In machines equipped with an hydraulic system, **regularly** check the level of water and glycol. If it is not sufficient, add the right amount. It is forbidden to use the system at a temperature below -5°C with the water+glycol mixture with which the machine is provided.
- ▶ You can lift the cap to inspect the evaporator. **Regularly** check that the evaporator functions properly.

**ATTENTION:**

on completion of each maintenance and cleaning operation, reset all the fastened protections.

5.3. Out of service, dismantling and demolition

To perform these dismantling and demolition operations, the following Individual Protection Devices are necessary:



5.3.1. Machine placed out of service

To place a machine out of service for a long period, follow the operations below:

1. Remove machine voltage.
2. Clean the machine.
3. Also conduct the maintenance operations and then cover the machine with a sheet.

5.3.2. Dismantling

If it is necessary to dismantle the machine, follow the procedures indicated below.

1. Isolate the machine from electrical power.
2. Refer to the *Paragraph 4.4.1 – De-installation in Chapter 4 – Transport and Installation*, proceed to de-install the machine; also contact the manufacturer's Technical Office to obtain the necessary support during this intervention.
3. To proceed to moving the machine components, work according to the instructions reported in *Paragraph 4.2 – Transport and Movement in Chapter 4 – Transport and Installation*.
4. Organise the components adequately based on the fact they have to be transported to another location (refer to *Paragraph 4.2 – Transport and Movement in Chapter 4 – Transport and Installation*), which must be stored (refer to *Paragraph 4.4 - Storage in Chapter 4 – Transport and Installation*) or demolished (refer to *Paragraph 6.3.3 - Demolition*).

**DANGER:**

the manufacturer declines all responsibility for any damage to property and/or persons deriving from improper interventions conducted by unqualified, untrained, inadequately equipped or unauthorised staff.

5.3.3. Demolition and disposal

When the machine has reached the end of its lifecycle, before proceeding to final disposal, it is necessary to perform a series of operations to minimise environmental impact linked to the disposal of the machine components, as requested by the norms in force on waste disposal.

These operations are:

1. Separate and store the parts with environmental impact, or rather:
 - a. separate the various parts that could cause pollution;
 - b. select the materials to encourage their recycling, dividing them for differentiated disposal (in particular select the plastic or rubber elements).
2. The gas contained in this system **must not** be dispersed in the environment. Thermal insulation of the buffer and oil in the compressor must undergo differentiated collection; for this reason, we recommend you dispose of the generator only in specialist collection centres and not as normal iron scrap, following the norm directives in force.
3. Dispose of the casing, or rather:
 - a. having removed and stored the polluting elements, entrust disposal of the casing to specialist structures.

ATTENTION:

on demolishing the machine, ensure the identification plate of the machine and the relevant technical documentation can no longer be used.

It is the faculty of the client to return these elements to the manufacturer's Technical Office for their destruction.

Simple conservation in an inaccessible location of the aforementioned elements is not permitted.

On completion of the interventions, communicate to the manufacturer's Technical Office that the machine has been disposed of.



6. Faults search

	POSSIBLE CAUSES	SOLUTIONS
A	<p><u>The compressor does not start up and does not release a humming sound</u></p> <ol style="list-style-type: none"> 1 Lack of voltage. Start-up relay with open contacts. 2 Thermal protector is intervening. 3 Loose electrical connections or wrong electrical connections. 	<ol style="list-style-type: none"> 1 Check the supply line or substitute the relay. 2 Check the electrical connections. 3 Tighten the connections or carry them out again in compliance to the electrical wiring diagram.
B	<p><u>The compressor does not start up (but releases a humming sound) and the thermal protector intervenes</u></p> <ol style="list-style-type: none"> 1 Wrong electrical connections. 2 Low voltage supply to the compressor. 3 Faulty start-up of the condenser. 4 The relay doesn't close. 5 The winding on the electrical motor is interrupted or in short circuit. 	<ol style="list-style-type: none"> 1 Re-do the connections. 2 Identify the cause and eliminate it. 3 Identify the cause and replace the condenser. 4 Identify the cause and substitute the relay if necessary. 5 Substitute the compressor.
C	<p><u>The compressor starts up, but the relay doesn't open</u></p> <ol style="list-style-type: none"> 1 Wrong electrical connections. 2 Low voltage supply to the compressor. 3 Relay blocked in closure. 4 Excessive discharge pressure. 5 The winding on the electrical motor is interrupted or in short circuit. 	<ol style="list-style-type: none"> 1 Check the electrical circuit. 2 Identify the cause and eliminate it. 3 Identify the cause and eliminate it. 4 Identify the cause and substitute the relay if necessary. 5 Replace the compressor.
D	<p><u>Intervention of the thermal protector</u></p> <ol style="list-style-type: none"> 1 Low voltage supply to the compressor (unbalanced phases on the tri-phase motors). 2 Defective thermal protector. 3 Defective electric-run condenser. 4 Excessive discharge pressure. 5 High suction pressure. 6 Overheated compressor, hot return gas. 7 Winding of the compressor motor in short circuit. 	<ol style="list-style-type: none"> 1 Identify the cause and eliminate it. 2 Check its characteristics and replace it if necessary. 3 Identify the cause and eliminate it. 4 Check the ventilation and any potential restrictions or obstructions in the system circuit. 5 Check the sizing of the system. Replace the condensing unit with a more powerful one, if necessary. 6 Check the refrigerant load; if need be, repair the loss and add gas if necessary till the charge stated in the label. 7 Replace the compressor.
E	<p><u>The compressor starts up and circulates, the functioning cycles are of brief duration</u></p> <ol style="list-style-type: none"> 1 Thermal protector. 2 Thermostat. 3 Intervention of the high pressure switch, due to the insufficient cooling of the condenser. 4 Intervention of the high pressure switch, due to the excessive load of refrigerant gas. 5 Intervention of the low pressure switch, due to the scarce load of refrigerant gas. 6 Intervention of the low pressure switch, due to the restriction or clogging of the expansion valve. 	<ol style="list-style-type: none"> 1 See previous point (thermal protector intervention). 2 Small differential; correct the regulation. 3 Check the correct functioning of the motor fan or clean the condenser. 4 Reduce the load of refrigerant gas. 5 Repair the loss and add refrigerant gas. 6 Replace the expansion valve.
F	<p><u>The compressor operates uninterruptedly or for long periods</u></p> <ol style="list-style-type: none"> 1 Scarce load of refrigerant gas. 2 Thermostat with contacts locked in closure. 3 System not sufficiently sized in function of the load. 4 Excessive load to cool or insufficient insulation. 5 Evaporator covered with ice. 6 Restriction in the system circuit. 7 Clogged condenser. 	<ol style="list-style-type: none"> 1 Repair the loss and add refrigerant gas till the charge stated in the label. 2 Replace the thermostat. 3 Replace the system with a more powerful one. 4 Reduce the load and improve insulation, if possible. 5 Perform defrosting till the charge stated in the label. 6 Identify the resistance and eliminate it. 7 Clean the condenser.
G	<p><u>Electric-run condenser damaged, interrupted, or in short circuit</u></p> <ol style="list-style-type: none"> 1 Wrong electric-run condenser. 	<ol style="list-style-type: none"> 1 Replace the condenser with the correct type.
H	<p><u>Start-up relay defective or burnt out</u></p> <ol style="list-style-type: none"> 1 Wrong relay. 2 Relay mounted in the incorrect position. 3 Wrong electric-run condenser. 	<ol style="list-style-type: none"> 1 Replace the relay with the correct one. 2 Re-assemble the relay in the correct position. 3 Replace the condenser with the correct type.
I	<p><u>Cold-room temperature too high</u></p> <ol style="list-style-type: none"> 1 Thermostat regulated too high. 2 Undersized expansion valve. 3 Undersized evaporator. 4 Insufficient air circulation. 	<ol style="list-style-type: none"> 1 Regulate it correctly. 2 Replace the expansion valve with a suitable one. 3 Replace it, increasing the surface of the evaporator. 4 Improve air circulation,
L	<p><u>Frosted suction piping</u></p> <ol style="list-style-type: none"> 1 Expansion valve with excessive passage of gas or oversized. 2 Expansion valve locked in open position. 3 Evaporator fan does not work. 4 Gas load too high. 	<ol style="list-style-type: none"> 1 Adjust the valve or substitute it with a correctly sized one. 2 Clean the valve of foreign substances and replace it, if necessary. 3 Identify the cause and eliminate it. 4 Reduce the load.

Schema frigorifero Refrigerator diagram

Figura 6 – Circuito mono-compressore raffreddamento ad aria / Mono-compressor circuit air cooling



Figura 7 – Circuito mono-compressore raffreddamento ad acqua / Mono-compressor circuit water cooling



Figura 8 – Circuito bi-compressore raffreddamento ad aria / Dual compressor circuit air cooling

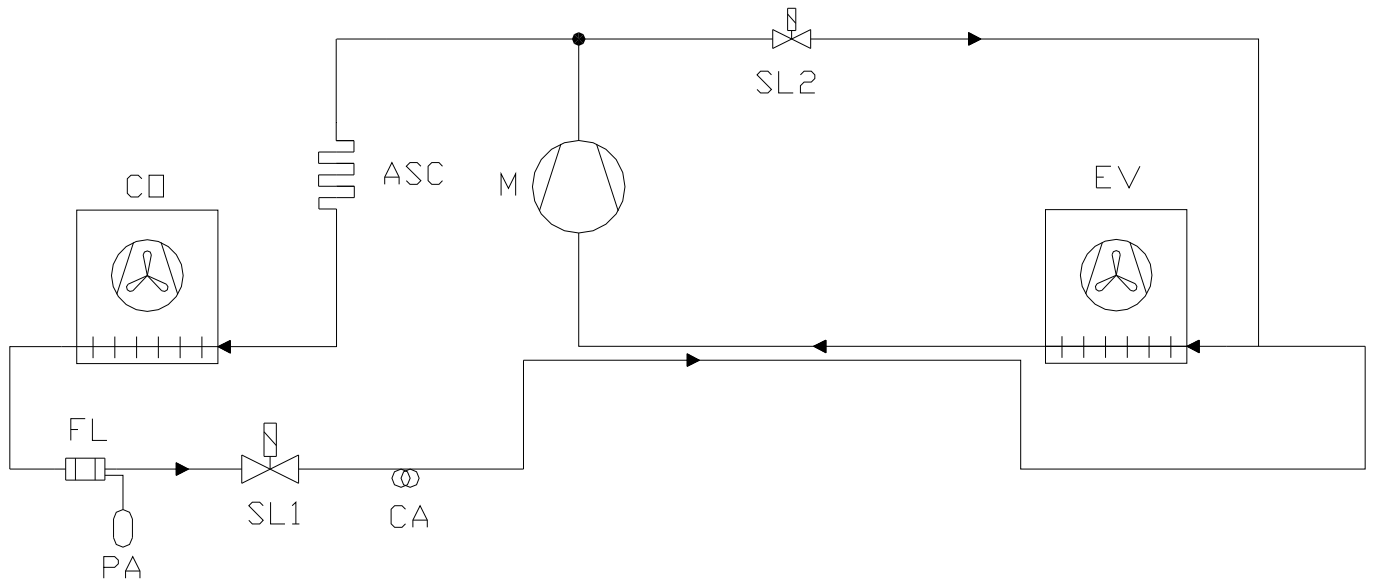

Figura 9 – Circuito bi-compressore raffreddamento ad acqua / Dual compressor circuit water cooling

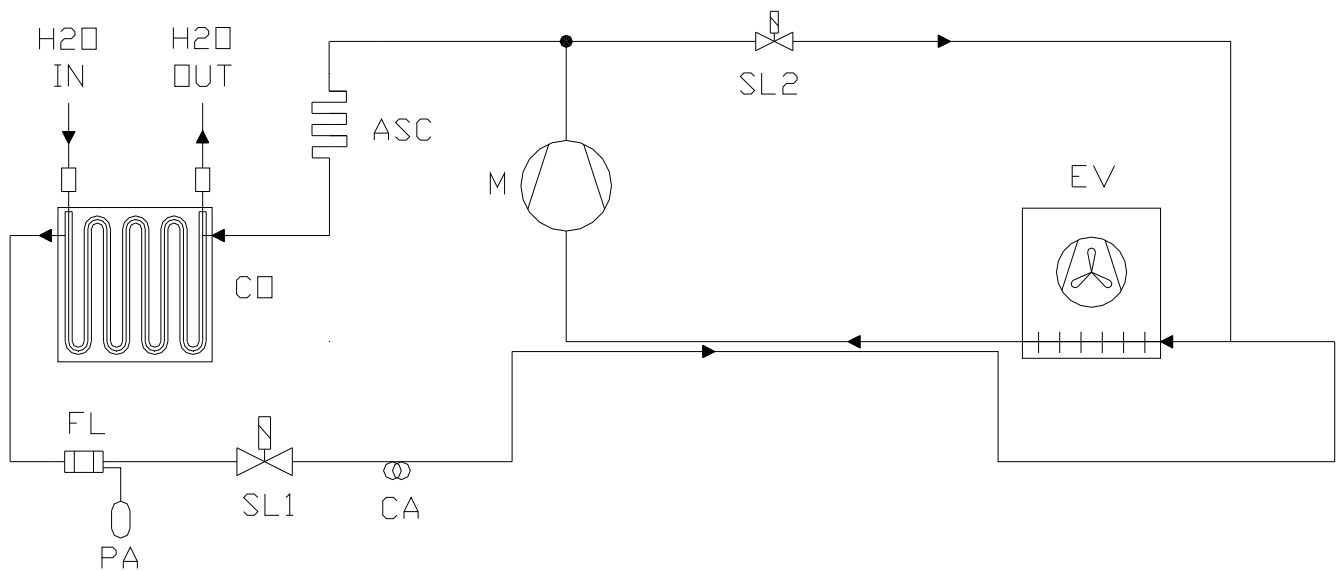
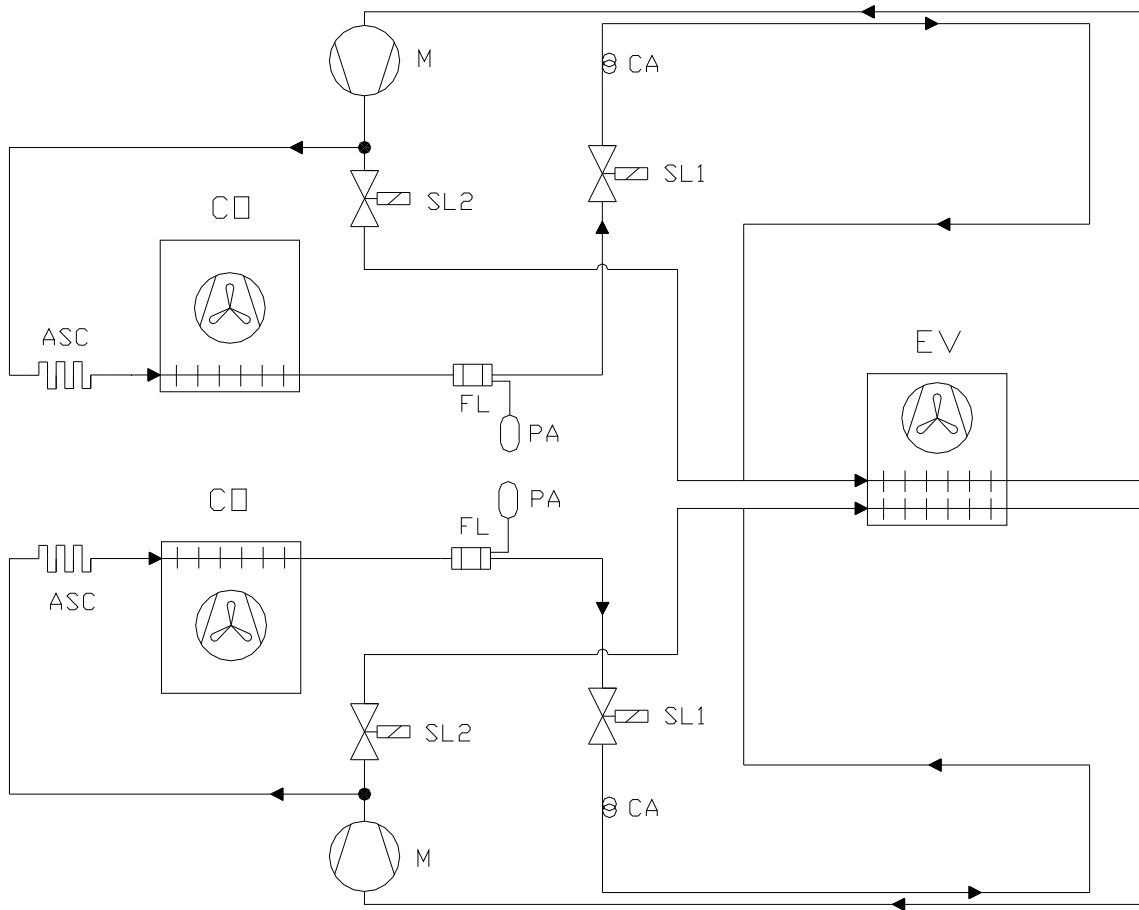
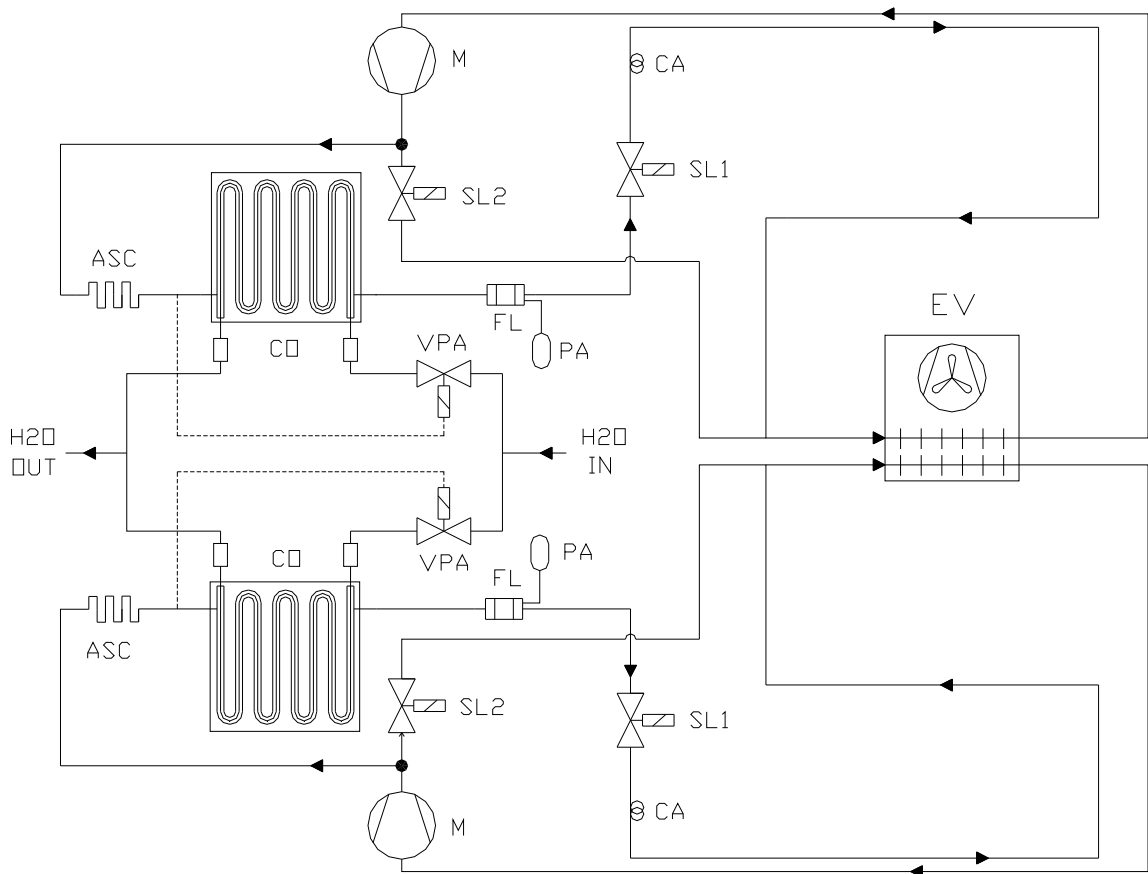

CO =	Condensatore / Condenser	SL2 =	Valvola Solenoide Gas Caldo / Hot gas solenoid valve
M =	Compressore / Compressor	EV =	Evaporatore / Evaporator
PA =	Pressostato di alta / High pressure switch	CA =	Capillare / Capillary tube
FL =	Filtro deidratatore / Drier filter	ASC =	Tubazione per evaporazione acqua di condensa Condensate water evaporating pipe
SL1 =	Valvola Solenoide del liquido / Liquid solenoid valve	VPA =	Valvola controllo pressione acqua Check valve pressure water

	SL1	SL2	VPA
MBP – ARIA AIR	–	•	–
MBP – ACQUA WATER	–	•	•
LBP – ARIA AIR	•	•	–
LBP – ACQUA WATER	•	•	•