



## **MOD : TA-85/IVAC**

**Production code : 7217042Aura 35+ + PIL/Aura 35+**

**05/2025**



TA-85/IVAC

- The machine is not suitable for the packaging of toxic, corrosive, irritant or potentially explosive materials.
- All persons responsible for the operation of this machine must at least fully read and understand the chapters about the operation and safety provided in these operating instructions.
- *All persons responsible for the assembly, installation, maintenance and/or repairs must fully read and understand these operating instructions.*
- *The user is at all times responsible for the interpretation and use of this manual. Contact the owner or the manager in case of questions or doubts about the correct interpretation.*
- *This manual should be kept near the machine and should be within reach for its users.*
- *All major maintenance work, modifications to the machine and observations must be kept in a logbook; see Logbook on page 69.*
- *Modifications to the installation/machine are not allowed without the prior written consent of the supplier.*
- *For specific maintenance work not included in this manual, please contact the supplier.*
- *Comply with the safety requirements as set out in Safety on page 9 at all times.*
- *The correct operation and safety of the system can only be guaranteed if the recommended maintenance is performed on time and properly.*
- *Illustrations shown may differ from your machine.*

# Contents

<b>List of Figures.....</b>	<b>5</b>
<b>1 Preamble.....</b>	<b>6</b>
1.1 List of the Symbols Used in this Manual.....	6
1.2 Qualified personnel.....	6
1.3 Storing the manual.....	7
1.4 Regulatory information.....	7
1.5 Terms of Warranty.....	7
1.6 Liability.....	8
1.7 Terms and abbreviations.....	8
<b>2 Safety.....</b>	<b>9</b>
2.1 Pictograms on the Machine.....	9
2.2 General Warnings.....	10
2.3 Warnings During Use.....	11
2.4 Warnings for Operating Personnel.....	12
<b>3 Introduction.....</b>	<b>13</b>
<b>4 Description of the Machine.....</b>	<b>14</b>
4.1 Aura series.....	14
4.1.1 Overview of the Main Components.....	15
4.2 Description of the Packaging Process/Machine Functions.....	16
4.2.1 Packaging Process/Machine Functions.....	16
4.2.2 General Functions.....	18
4.3 Sealing System.....	19
<b>5 Installation.....</b>	<b>20</b>
5.1 Transportation and Installation.....	20
5.2 Connecting the Machine.....	20
5.3 Prior to the First Use.....	21
<b>6 Operation.....</b>	<b>22</b>
6.1 Aura Control System.....	23
6.1.1 Control Panel.....	23
6.1.1.1 Favourites.....	24
6.1.1.2 Product programs.....	25
6.1.1.3 Function programs.....	27
6.1.1.4 Manual use.....	28
6.1.2 Settings.....	29
6.1.2.1 User management.....	29
6.1.2.2 User settings.....	30
6.1.2.3 Maintenance & Service.....	37
6.1.2.4 Import & Export.....	39

6.1.2.5 Test.....	42
6.1.3 Switch user.....	42
6.1.4 Basic operation.....	43
6.1.4.1 Starting the machine.....	43
6.1.4.2 Starting the Packaging Cycle.....	43
6.1.4.3 During the vacuum cycle.....	44
6.1.5 External vacuum.....	45
6.1.6 Guidelines for function values.....	45
6.2 Printer.....	47
6.2.1 Creating a Label.....	47
6.2.2 Replacing a Printer Roll.....	48
6.2.3 Aligning the Printer.....	49
<b>7 Maintenance.....</b>	<b>50</b>
7.1 Maintenance Schedule.....	50
7.2 Cleaning the Machine.....	51
7.3 Replacing the Sealing Wire.....	51
7.4 Replacing the Silicone Rubber of the Silicone Holders.....	53
7.5 Replacing the Lid Gasket.....	54
7.6 Inspecting the Lid Springs.....	55
7.7 Vacuum Pump maintenance.....	55
7.7.1 Overview.....	55
7.7.1.1 Busch pump 8 m <sup>3</sup> /h.....	55
7.7.1.2 Busch pump 16 - 21 m <sup>3</sup> /h.....	56
7.7.1.3 Becker pump 16 - 21 m <sup>3</sup> /h.....	57
7.7.2 Service hatch.....	58
7.7.3 Removing Oil, Refilling Oil.....	58
7.7.4 Replacing the Oil Exhaust Filter.....	59
7.7.4.1 Busch pump 8 m <sup>3</sup> /h.....	59
7.7.4.2 Busch pump 16 - 21 m <sup>3</sup> /h.....	60
7.7.4.3 Becker pump 16 - 21 m <sup>3</sup> /h.....	61
7.7.5 Running the Pump Cleaning Program.....	62
<b>8 Troubleshooting and Error Codes.....</b>	<b>63</b>
<b>9 Disposal.....</b>	<b>65</b>
<b>10 Appendices.....</b>	<b>66</b>
10.1 Technical Data.....	66
10.1.1 Aura series.....	66
10.2 Electrical Installation.....	67
10.3 Vapour Pressure Curve of Water.....	68
10.4 Logbook.....	69

# List of Figures

Figure 1: Overview of the Main Components.....	15
Figure 2: Overview of the Sealing System.....	19
Figure 3: Replacing the Printer Roll.....	48
Figure 4: Aligning the Printer.....	49
Figure 5: Printing the First Label.....	49
Figure 6: Replacing the Sealing Wire.....	52
Figure 7: Replacing the Silicone Rubber of the Silicone Holders.....	53
Figure 8: Replacing the Lid Gasket.....	54
Figure 9: Overview of the Busch pump.....	55
Figure 10: Overview of the Busch pump.....	56
Figure 11: Overview of the Becker pump.....	57
Figure 12: Replacing the Oil Exhaust Filter.....	59
Figure 13: Replacing the Oil Exhaust Filter.....	60
Figure 14: Replacing the Oil Exhaust Filter.....	61
Figure 15: Overview of the Electrical Installation.....	67
Figure 16: Vapour Pressure Curve of Water.....	68

# 1 Preamble

This is the manual for your Henkelman Vacuum Packaging Machine series: /

This manual is intended for anyone who works with or services the machine.

This manual contains information and instructions for installation, operation and maintenance of the machine. We recommend that you carefully read this manual before use and follow the procedures and instructions strictly. This will ensure that you get the best out of the machine and prevents possible accidents and serious injury.

## 1.1 List of the Symbols Used in this Manual

For all operations in which the safety of the operator and/or technician is at stake and where caution should be exercised, the following symbols are used.



Indicates a hazardous situation that, if not avoided, could result in serious injury or death and possibly material damage if one does not follow the safety instructions.



Indicates a hazardous situation that, if not avoided, could result in minor or moderate injury and possibly material damage if one does not follow the safety instructions.



Provides additional information that is helpful to do a task or to avoid problems.



This symbol warns for high voltage.

## 1.2 Qualified personnel

This document is intended for qualified personnel.



The term "qualified personnel" is defined here as individuals who thoroughly understand the equipment and its safe installation, operation or maintenance. Qualified personnel are physically capable of performing the required tasks, are familiar with all relevant and local safety rules and regulations and have been trained to safely install, operate or maintain the equipment. It is the responsibility of the company installing, operating or maintaining this equipment to ensure that its personnel meet these requirements.

## 1.3 Storing the manual

This manual is a part of your product. Store the manual in the immediate vicinity of the product. Always present a copy of the manual to operators and engineers working on the vacuum Packaging Machine.

## 1.4 Regulatory information

The Henkelman Aura Vacuum Packaging Machine is designed to comply with the following directives:

- 2006/42/EC: Machinery Directive
- 2014/30/EG: EMC Directive



The EC declaration is included with the shipment of the machine. A copy is available upon request, please contact the manufacturer.

## 1.5 Terms of Warranty

The warranty is subject to the following limitations. The warranty period for products supplied by Henkelman BV is from the date indicated on the purchase document. This warranty is limited to manufacturing and machining defects and therefore does not cover breakdowns involving any part of the product that is exposed to any form of wear and tear. Normal wear and tear that may be expected with the use of this product is therefore hereby excluded.

- The responsibility of Henkelman BV is limited to replacing defective parts; we shall not acknowledge claims for any other kind of damage or costs.
- The warranty automatically expires in case of overdue or poor maintenance.
- If there are doubts about the maintenance activities or if the machine fails to work correctly, always contact the supplier.
- The warranty does not apply if the defect is the result of incorrect or negligent use, or maintenance that was conducted contrary to the instructions given in this manual.
- The warranty is void in the event of repairs or modifications to the product by third parties.
- Defects due to damage or accidents caused by external factors are excluded from the warranty.
- If we replace parts in compliance with the obligations of this warranty, then the replaced parts become our property.

The provisions regarding the warranty and liability are part of the general terms and conditions of sale, which can be sent to you upon request.

## 1.6 Liability

- We exclude all liability insofar as far as it is not required by law.
- Our liability shall never exceed the total amount of the machine value in question.
- With the exception of the applicable legal regulations of public order and good faith, we are not liable to pay for any damage of any sort whatsoever to the opposite party or to third parties, directly or indirectly, including lost profits, damage to movable or immovable property or personal injury.
- We are in no way liable for damages arising from or resulting from the use of the product used, or the unsuitability thereof for the purpose for which the other party decided to purchase the product.

## 1.7 Terms and abbreviations

Machine	Vacuum Packaging Machine
Pump	Vacuum pump

## 2 Safety

Your Vacuum Packaging Machine has been carefully designed and expertly tested to be operated safely. This is corroborated by the CE-marking. However, there are always dangers and safety risks that cannot be eliminated. These dangers and risks are the result of the use functions of the machine and operation of the machine by the user. This section discusses safety instructions and precautions, how they will be pointed out to you and the requirements the user must meet. It is essential that you are well aware of these safety instructions and requirements and observe them at all times!

### 2.1 Pictograms on the Machine

Pictograms and warnings have been fitted on the machine to warn users of the possible risks.



Warning sign "High Voltage"

- Is located on the back of the machine



Warning sign "Heat"

- Is located on the sealing bars and on the vacuum pump



Warning sign "Gas Connection" (optional)

Forbidden to connect oxygen. Only nutritional gases or inert gases are allowed.

- Is located on the back of the machine

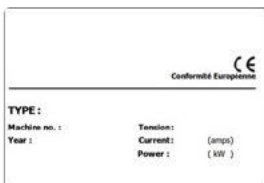

Machine plate

- Is located on the back of the machine



Regularly check whether the pictograms and markings are still clearly recognisable and legible. Replace them if this is not the case.

## 2.2 General Warnings

---



- All persons responsible for the operation of this machine must at least fully read and understand the chapters *Safety* on page 9 and *Operation* on page 22.
- Failure to follow or disregard of the safety instructions may result in serious injury.
- Never pack products that can be damaged by vacuum.
- Never vacuum live animals.
- Warranty and/or liability is void if any damage is caused by repairs and/or modifications that are not authorised by the supplier or any of its distributors.
- In case of malfunction, contact the supplier.
- High pressure cleaning is not allowed. This may cause damage to the electronics and other components.
- Prevent water from entering the ventilation inlet of the chamber or the exhaust of the pump. This causes irreversible damage to the pump.
- The work space around the machine must be safe. The owner of the machine must take the necessary precautions to operate the machine safely.
- It is forbidden to start the machine in an explosive environment.
- The machine has been designed in such a way that production is safe under normal ambient conditions.
- The owner of the machine must ensure that the instructions in this manual are actually complied with.
- The available safety devices may not be removed.
- The correct operation and safety of the system can only be guaranteed if the recommended maintenance is performed on time and properly.
- If work must be carried out on the machine, it must be disconnected and blocked from the power supply and, if applicable, from the air and gas supply.
- The power cord and plug must be accessible at all times. Disconnect the power plug if an error occurs.



- Only a technical expert may perform work on the electrical installation.
- Internal procedures and monitoring must be in place to ensure that all relevant power supplies are disconnected.
- The machine may not be used during cleaning, inspection, repair or maintenance and must be disconnected from the power supply by disconnecting the plug.
- Never perform welding work on the machine without first disconnecting the cable connection to the electrical components.
- Never use the power supply of the control unit to connect other machines.
- All electrical connections must be connected to the terminal strips according to the wiring diagram.

## 2.3 Warnings During Use

---



- Before starting the machine, make sure no work is being performed the installation and that the machine is ready for use.
- The machine may not be operated by unauthorised persons. This should be monitored by the machine operator(s).
- Immediately contact the service technician of your technical department or dealer if something does not seem right, such as unusual vibrations or unusual noise.
- If the gassing option is used, the gas supply must be shut off when the machine is no longer in use. The work area must also be sufficiently ventilated.
- The machine may not be used if the plastic lid shows visible damage or cracks. Contact your dealer for professional service.
- Components of the sealing system can become very hot. Contact with these components may cause injuries.
- Improper use, such as switching off the machine while it is creating a vacuum, is strongly discouraged. Such actions may cause oil leaking back to the vacuum chamber.

## 2.4 Warnings for Operating Personnel

---



- Operating personnel must be 18 years or older.
- Only authorised persons are allowed to perform work on or with the machine.
- Personnel may only perform work for which it was trained. This applies to both maintenance and normal use.
- The machine may only be operated by trained personnel.
- The machine must never be unattended during operation.
- Operating personnel must be familiar with all circumstances, so quick and effective action can be taken in case of an emergency.
- If an operator notices errors or risks or disagrees with safety measures, he or she should report this to the owner or manager.
- Safety shoes are mandatory.
- Appropriate work clothing is mandatory.
- All personnel must obey the safety regulations to avoid danger to themselves and others. Always strictly follow the work instructions.

### 3 Introduction

Henkelman BV is a supplier of ultra-modern vacuum packaging machines. Our machines are developed and manufactured to meet the highest standards. They combine a sleekly build and functional design with optimal ease of use and a long service life. After mounting the plug, it is just a matter of "plug & pack". The clever design ensures compliance with the hygiene standards at all times.

The Aura series consists of high-quality tabletop models designed for professional use, emphasizing user-friendliness and minimal maintenance requirements. These models are crafted to meet the demands of professionals, offering not only exceptional performance but also an intuitive and hassle-free experience for users. Additionally, their design prioritizes ease of maintenance, ensuring that routine upkeep is both straightforward and efficient.

## 4 Description of the Machine

This section provides an short introduction to the machine and an overview c ain components and functions. If detailed information is available in this manual, you will be referred to the specific sections.

### 4.1 Aura series

Basic vacuum packaging machines for basic packaging needs. The Aura series represent a range of compact table-top models.



All Aura models are equipped:

- Pre-programs for a wide range of products
- Standard with Liquid control
- Standard with double seal
- Standard with soft-air
- Standard delivered with insert plates
- Free options: Cut-off and Wide seal
- Paid option: Gas flush

## 4.1.1 Overview of the Main Components

The figure below shows the main components of the Aura series. The model shown may differ from your machine.

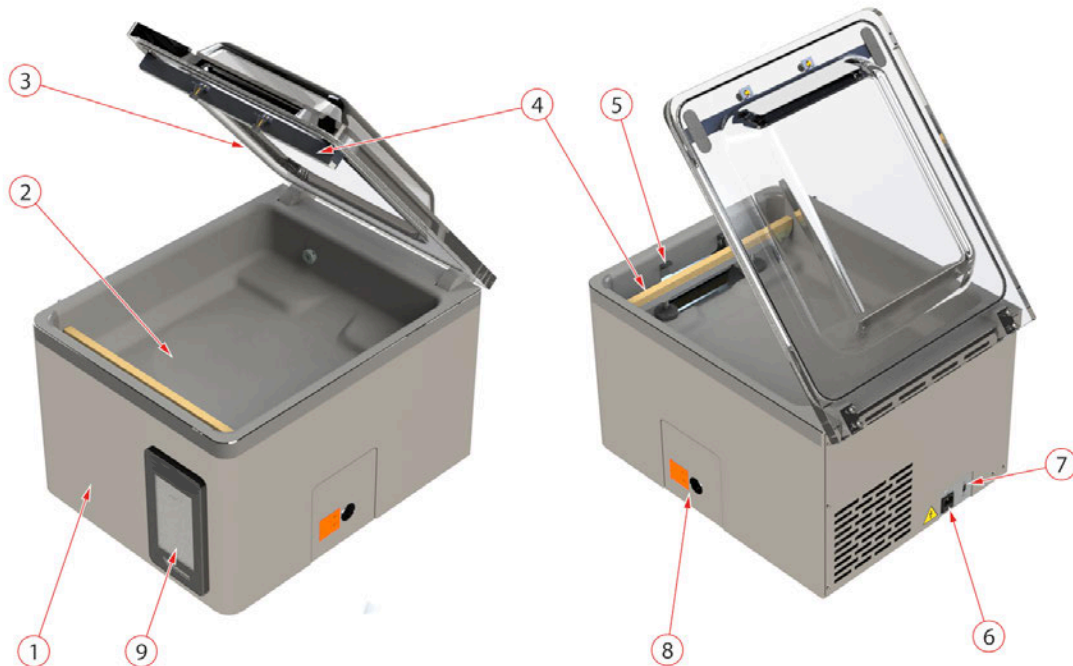

Figure 1: Overview of the Main Components

### 1. Machine housing

The machine housing contains all the components necessary for the functioning of the machine.

### 2. Vacuum chamber

The products to be packaged are placed on the work surface with the openings of the vacuum bags on the sealing position.

### 3. Lid

The lid closes the vacuum chamber during the application of the vacuum. A rubber is mounted in the lid to ensure proper closing. Silicone holders are mounted in the lid as counter beams of the sealing bar(s).

### 4. Seal system

Depending on the model, one or two sealing bars are mounted in the vacuum chamber. These close the vacuum bag.

### 5. Vacuum bag retainer

This system holds the open end of the vacuum bag in place.

### 6. Power connection

This serves to connect the machine to the power supply.

### 7. Circuit breaker

The circuit breaker protects against overload or short circuit.

### 8. Vacuum pump

The vacuum pump creates the vacuum. The hatch can be removed to access the vacuum pump.

## 9. Control panel

This serves to operate the available control functions.

## 4.2 Description of the Packaging Process/Machine Functions

This section provides an overview of the packaging process and available machine functions.



See *Configure Product programs* on page 32 for information about setting the parameters to the correct values.

### 4.2.1 Packaging Process/Machine Functions

This section describes the packaging process and the machine functions. See *Operation* on page 22 for the realization of the specific steps of the procedure.

Step	Process phase	Operation
1.	<b>Preparation</b>	The operator puts the product in a vacuum bag and places it on the work surface with the opening on the sealing position.
2.	<b>Applying vacuum</b>	The vacuum process is initiated by closing the lid.  Depending on the options you selected for your machine and the product you are packaging, the following functions are available:
	<b>Vacuum</b>	During the cycle, the air is removed from the chamber until the set pressure has been reached.
	<b>Vacuum+</b>	Vacuum+ is only available if the vacuum percentage is set to the maximum.  The Vacuum+ option continues the vacuum process for an additional time to allow any entrapped air to escape from the product.
	<b>Gas (optional)</b>	After applying vacuum, a gas is injected into the package to create a modified atmosphere to protect the shape of the product or to increase the shelf life of the product. The value of the gas function can be set in %, mbar or hPa.
	<b>Gas+ (optional)</b>	The Gas+ option continues injecting gas during the closing of the bars to increase the amount of gas in the package.

Step	Process phase	Operation
<b>Liquid Control</b>	<p>With the Liquid Control option, the system is controlled by a highly sensitive sensor. The sensor is able to detect the moment that liquids from the product or the product itself begin to evaporate (boil).</p> <p>At that time the system will proceed to the next step in the process. This will prevent the product from dehydrating, losing weight and/or the vacuum bag from bursting, thus contaminating the seal, the chamber, and the oil in the pump.</p>	
<b>Liquid Control+</b>	<p>The Liquid Control+ function allows you to continue the vacuum process for a certain time after the evaporation point has been reached.</p>	
<b>Red meat</b>	<p>This option is especially designed for the packaging of fresh meat. It is added to the normal vacuum function to prevent degassing of the product during and after the sealing phase. This degassing could create air pockets inside the package.</p>	
<b>Sequential Vacuum</b>	<p>With sequential vacuum, you can alternate vacuum and pause steps to allow air trapped inside a product to escape from the core. A maximum of 5 steps can be programmed.</p>	
<b>Marinating</b>	<p>This function is especially designed to accelerate the marinating of a product. This program allows definition of up to 5 vacuuming steps with intermediate ventilation steps.</p>	
<b>Tenderising</b>	<p>This feature has been designed to keep the chamber at a pre-determined vacuum level for a certain time. This is done to tenderise or degas the product.</p> <p>During the cycle, the air is removed from the chamber until the pre-set value has been reached. Once this value has been reached, the chamber will remain at this vacuum level for the pre-set time.</p>	
<b>Jars</b>	<p>This is a fast program specially designed for vacuum sealing jars. The seal and soft-air phase are shut off during this program. Only undamaged preserving jars with lids suitable for vacuuming must be used.</p> <p>During the cycle, the air is removed from the chamber until the pre-set value has been reached. During the fast decompression the lids are being closed.</p>	

Step	Process phase	Operation
3.	<b>Sealing</b>	The sealing bars are pressed against the vacuum bag and melt the bag closed.
	<b>Seal</b>	During the sealing process, the material of the vacuum bag is heated and pressed together to create a hermetic seal.  Optionally, a cut-off wire is available. The purpose of the cut-off wire is to remove the excess foil.
4.	<b>Decompressing</b>	The vacuum is removed from the vacuum chamber by letting air into the chamber.
	<b>Soft-Air</b>	This function allows air from outside to slowly enter the chamber so the vacuum bag will shape itself slowly around the product. This prevents sharp edges of the product from puncturing the foil and causing leaks.
5.	<b>Opening the vacuum chamber</b>	The lid opens.
6.	<b>Removing the product</b>	The operator can remove the packaged product from the work surface.

#### 4.2.2 General Functions

Function	Operation
<b>Cleaning of the pump oil</b>	The pump cleaning program ensures that the pump is thoroughly rinsed. During the program, the pump and oil reach the operating temperature, so the oil and moisture are separated and any contamination is filtered. The high temperature causes any moisture in the pump to evaporate, thus minimising the risk of corrosion.
<b>Printing (optional)</b>	This function allows the creation of one or more labels per cycle, to be put on the packaging.  The following information can be printed on the label: name of the producer, name of the product, production date, shelf life, achieved vacuum, initials of the user, recommended storage temperature and an information field (for example to indicate the gas used).
<b>External Vacuum (optional)</b>	This function allows special food containers to be vacuumed outside the machine.



Use only undamaged preserving jars with lids suitable for vacuuming.

## 4.3 Sealing System

The sealing system closes the opening(s) of the bag to retain the vacuum and as in the bag. The end of the bag can optionally be cut off by the sealing bar.

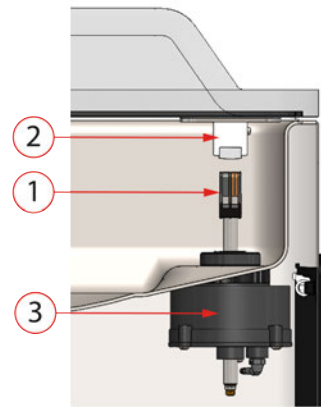

Figure 2: Overview of the Sealing System

### 1. Sealing bar

The sealing bar consists of the following components:

- Sealing wires: during the sealing process, the sealing wires are heated for a certain time causing the edges of the vacuum bag to melt together.
- Cut-off wires (optional): A cut-off wire is heated in such a way that the foil of the bag partially melts, allowing the excess foil of the vacuum bag to be removed easily.
- Teflon tape: sealing and cut-off wires are covered with Teflon tape to prevent the bag from sticking to the sealing bar.

Consult *Replacing the Sealing Wire* on page 51 for more detailed information about maintenance.

### 2. Silicone holder

Opposite the sealing bar is a silicone holder which provides counter pressure on the cylinders (*Replacing the Silicone Rubber of the Silicone Holders* on page 53).

### 3. Sealing mechanism

The sealing bars are pressed onto the vacuum bag by cylinders. By connecting the inlet of the cylinders with the atmospheric pressure outside, they press the sealing bar onto the bag.

## 5 Installation

Consult *Technical Data* on page 66 for the specifications of the machine.



Before installing the machine, carefully read the safety instructions in *Safety* on page 9. Failure to follow or disregard of the safety instructions may result in serious injury.

### 5.1 Transportation and Installation

The machine must be moved and transported in an upright position.

1. Place the machine on a flat, level surface. This is essential to ensure a trouble-free operation of the machine.



Do not position machines with plastic covers in the vicinity of a heat source.



Make sure there is sufficient space (at least 15 cm) around the machine to ensure a proper ventilation.

2. Verify that the machine housing is present and correctly fitted.

### 5.2 Connecting the Machine



Only a technical expert may perform work on the electrical installation.

Make sure the power supply for this machine matches to the voltage and current stated on the machine plate.

1. Fit the connecting cable to the machine. See *Technical Data* on page 66 for the correct electrical connection.
2. Connect the machine to a grounded wall outlet to avoid fire or electric shock.



- The power cable must be free at all times, and nothing may be placed on it.
- The power plug must be accessible at all times. Remove the plug from the power socket when an error occurs, or when maintenance is performed on the machine.
- Immediately replace the power cable if damaged.

3. Optional: Connect the gas supply for the gas flush system.

## 5.3 Prior to the First Use

See *Vacuum Pump maintenance* on page 55 for more information how to perform these steps.

Prior to the first use, the following steps must be performed:



Failure to do so may result in unrepairable damage to the machine.

1. Check the oil sight glass to see if the amount of oil in the pump is sufficient.
2. Optional: If the amount of oil in the pump is insufficient, refill it.
3. Start up the machine. See *Operation* on page 22 for more information.

## 6 Operation

---



- All persons responsible for the operation of this machine must at least fully read and understand the chapters *Safety* on page 9 and *Operation* on page 22.
- Failure to follow or disregard of the safety instructions may result in serious injury.

## 6.1 Aura Control System

### 6.1.1 Control Panel

The control panel allows the machine to be operated and programmes to be changed. This screen presents the user with 9 buttons, providing access to the various functions.

#### 1. Favourites

When this button is pressed, the user is presented with the list of saved favourites. See: *Favourites* on page 24.

#### 2. Product Programs

By pressing this button, users are guided with selecting the most ideal program. See: *Product programs* on page 25 for more details.

#### 3. Function Programs

When this button is pressed, quick access is provided to a selection of functions that are not directly related to a specific product. See *Function programs* on page 27 for details.

#### 4. Manual use

Enables the user to completely define the program as desired. See: *Manual use* on page 28 for details.

#### 5. Settings

The settings menu contains a wide variety of options and features that do not have to be changed on a daily basis, such as import/export, maintenance tests, units, languages and many more.

Depending on the authorisation level signed in settings can be read or written. See *Settings* on page 29

#### 6. Switch user

Several user levels can be set up to provide a hierarchy in the software. E.G. Chefs can adjust and finetune programs where the kitchen help can only use the presets. See *Switch user* on page 42

#### 7. Home

Pressing this button will always revert to the main screen.

#### 8. Clean pump

When this button is pressed a dialog pop up with information about the pump conditioning cycle, the cycle can also be started from this position by closing the lid.

#### 9. Standby button

Serves to turn off the display of the Aura.

A LED will light up when the AURA is in standby mode.



### 6.1.1.1 Favourites

To assist the user a list of favourites are available. This allows the user to have a specific set of programs on speed dial.



### 6.1.1.2 Product programs

To assist the user a set of product programs are predefined. Users are guided with selecting the most ideal program, starting off with the product category.

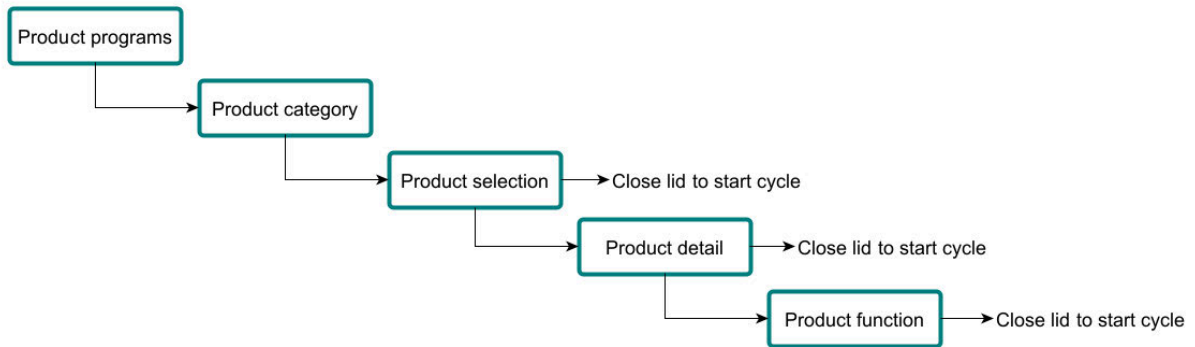

From the home page, **product programs** can be selected.

Next the **product category** can be selected..

The next step is to make the **product selection**. At this point the lid can be closed to start the vacuum cycle.

When more refinement is desired a **product detail** can be selected, this will alter the presets to suit its needs.

At last a **product function** can be added such as functions like marinating, tenderising and sequential.

Closing the lid after every refinement will start the vacuum cycle.

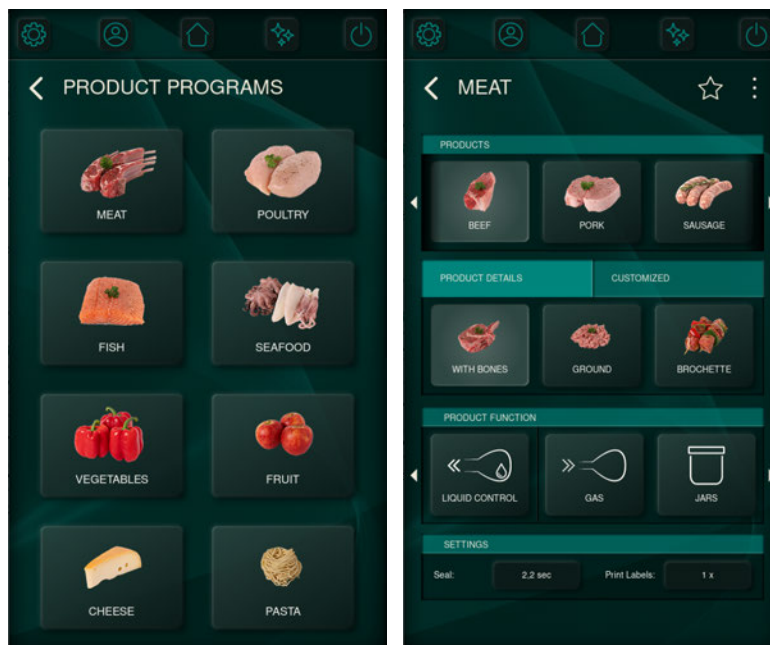

### 6.1.1.2.1 Chefs note

To provide some support during the selection process a chefs note can be added. This specific note can include advice on what to keep in mind when packaging the product t additional product functions are advised and many more.

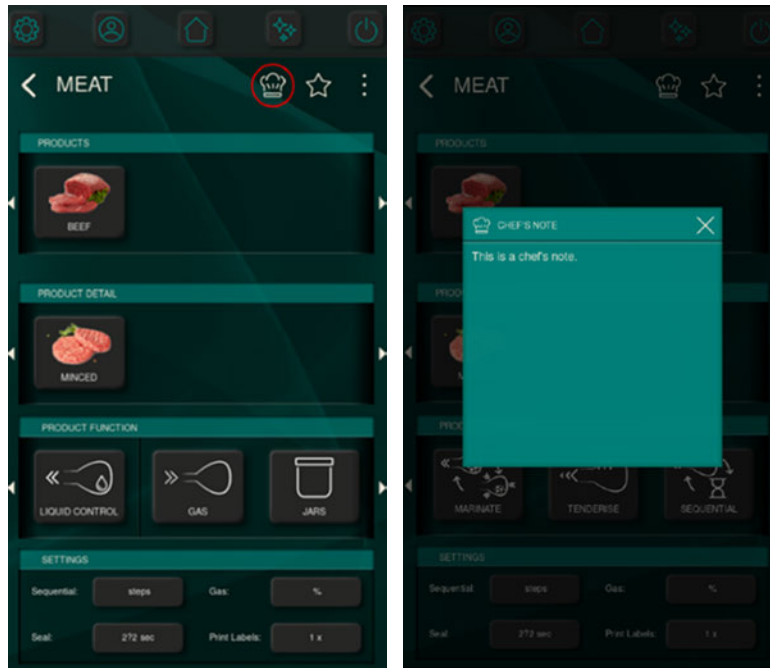

### 6.1.1.2.2 Mark favourites

When the Star icon is pressed the selected program will be marked as favourite and is added to the product favourites list, which is easily accessed from the home screen. This allows the user to have a specific set of programs on speed dial.

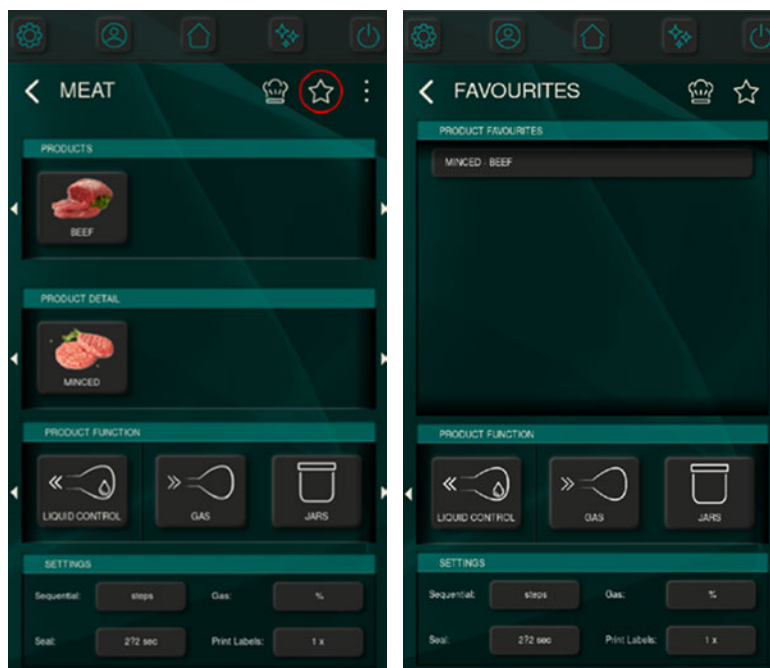

### 6.1.1.3 Function programs

The function programs menu provides quick access to a selection of functions that are not directly related to a specific product. The amount of parameters available under the function program is condensed to the most influential, so that the user can quickly start the process.

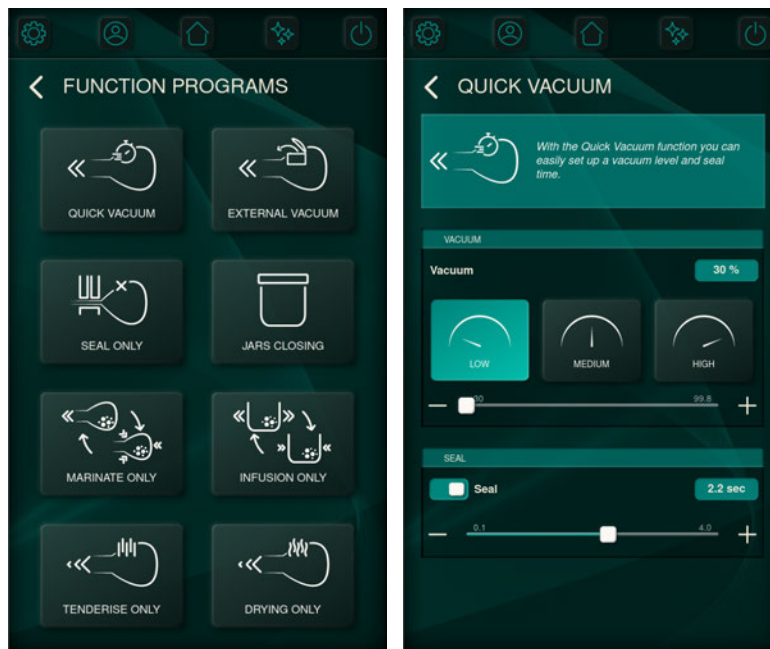

#### 6.1.1.4 Manual use

Selecting the 'MANUAL USE' from the home screen allows the user to completely define the programs as desired. Swiping through the menus will give you all the change parameters regarding vacuuming, gas flush<sup>1</sup>, sealing, aerating, print label info<sup>2</sup> as well as the parameters that define the product functions such as tenderizing and marinating.

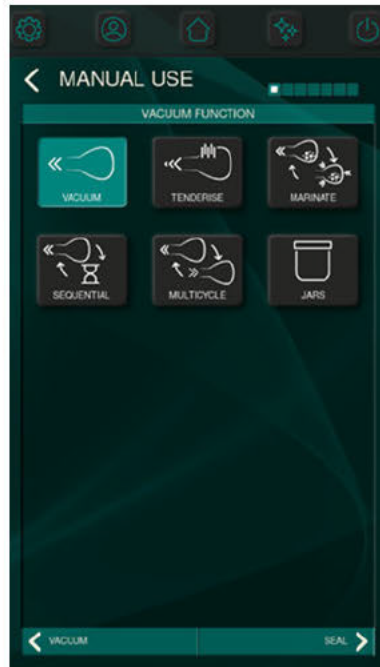

Never use a gas mixture containing more than 20% oxygen or other explosive gases. This may cause life-threatening explosions. Only nutritional gases or inert gases are allowed.

---

<sup>1</sup> If the gas system is installed.

<sup>2</sup> If a label printer is connected.

## 6.1.2 Settings

Access to the settings menu is possible directly from the home screen, as demonstrated in Chapter *Control Panel* on page 23

In the settings menu, you will find options that don't require daily adjustments. This menu also offers extended customization possibilities for those seeking to fine-tune their preferences.

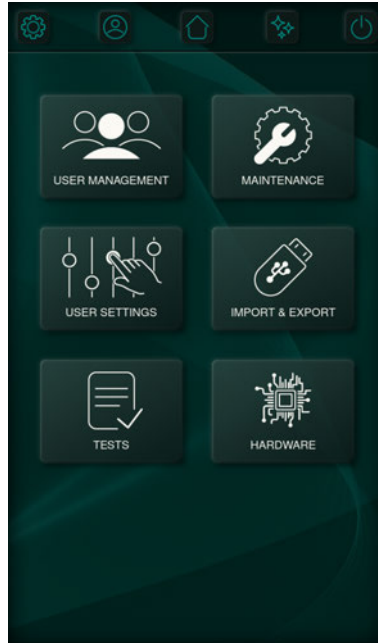

### 6.1.2.1 User management

The user management menu facilitates the creation, modification, and viewing of user profiles. It offers distinct roles tailored to user needs. Basic users can execute fundamental actions like program execution for a straightforward experience. In contrast, owners have advanced privileges, enabling them to fine-tune system settings, modify existing programs, and craft new ones.

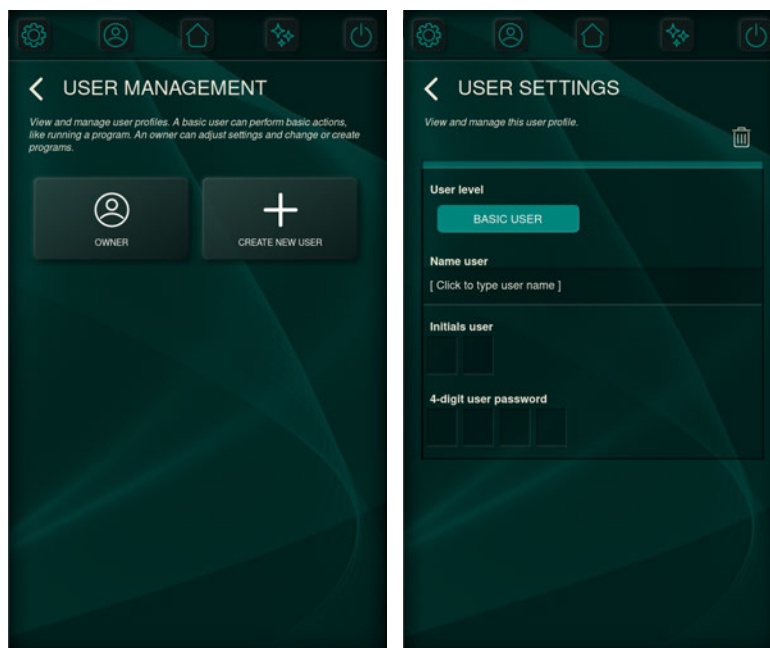

### 6.1.2.2 User settings

Within the user settings menu, users can access a secondary level of personalization. This advanced level of customization allows users to modify aspects related to the user interface, including the visibility of programs and functions.

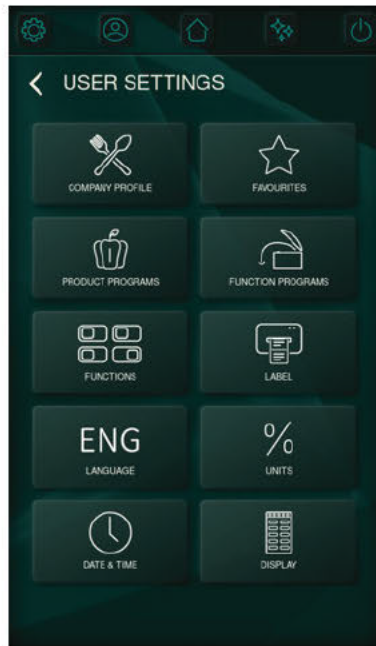

#### 6.1.2.2.1 Company profile

By selecting a company profile, you create a better fitting initial configuration of the programs and functions. This configuration can be further tweaked in the *User settings* on page 30.



Beware, selecting a company profile undoes all manual configuration actions.



### 6.1.2.2.2 Configure favourites

This menu is responsible for configuring the product programs listed in the favorites menu. By using the up and down buttons, you can rearrange the order in which programs appear in the favorites menu on the home screen. If you wish to remove a product from the list, simply select the program and deselect the star button. Rest assured, any changes made in this menu are automatically saved when you exit, ensuring that your preferences are retained.



### 6.1.2.2.3 Configure Product programs

To improve the efficiency and user comfort product programs can be ordered, hidden and deleted.

Use the eye button to show or hide a product program, hidden programs will not be visible in the product program menu. Use the left and right arrow buttons to change the order of the product programs. The trash can icon can be used to permanently delete a program (only possible for custom programs).

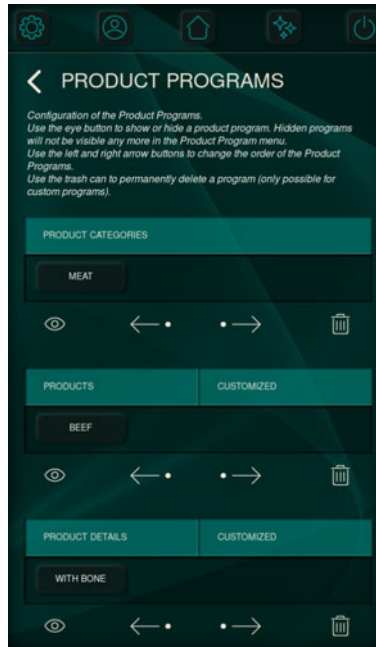

#### 6.1.2.2.4 Configure function programs

Optimizing the arrangement of function programs and concealing unnecessary ones enhances the overall user experience. You can utilize the up and down arrow buttons to determine the order in which functions are presented, while the eye button allows you to hide functions that are not needed.

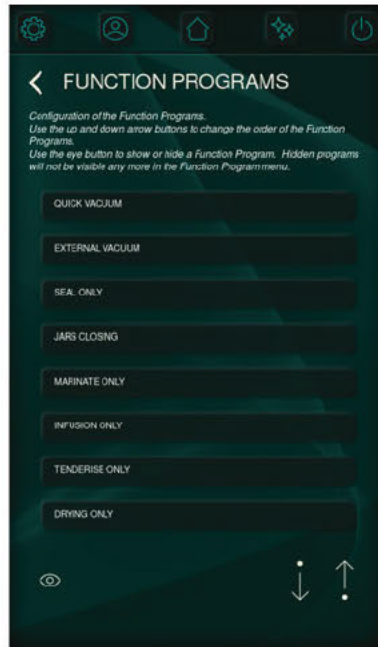

Function programs cannot be deleted

### 6.1.2.2.5 Configure functions

The number of functions available for use is determined within the functions menu. When a function is switched off, it becomes invisible and cannot be further configured. In cases where it has already been utilized in pre-existing programs

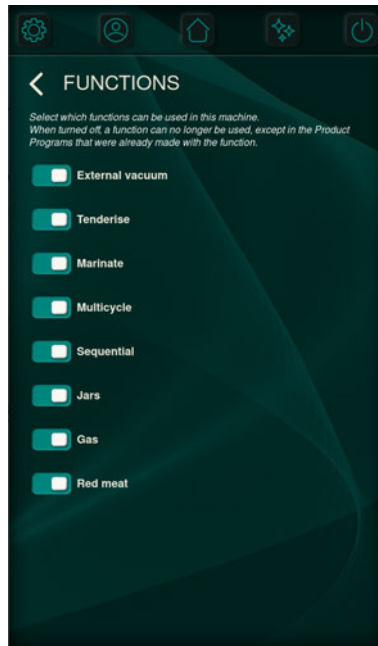

### 6.1.2.2.6 Configure labels

If the machine is equipped with a label printer a default label can be defined. However, printable information can still be altered in the manual use or product programs workflow.

#### Printable label data:

- Customer name
- Information
- Date
- Expiry date based on storage life
- Storage temperature
- Achieved vacuum
- User name

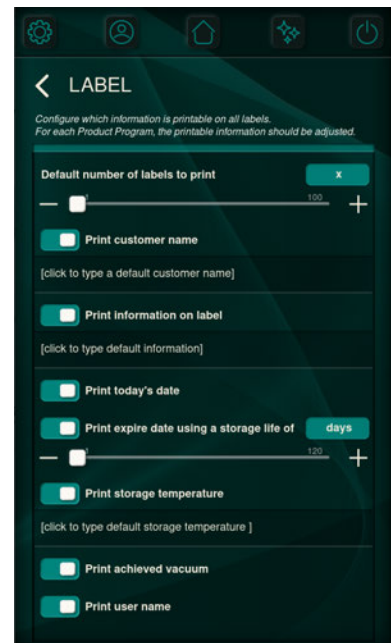

### 6.1.2.2.7 Configure Date&Time, Language and Units

The date and time settings can be changed to all the standard formats. The set date and time is also linked to HACCP data and can be printed on the labels.

A selection of languages and units can be chosen.

Units for temperature and vacuum also define the way they are displayed on the printed labels.



Settings are saved when the menu is closed.

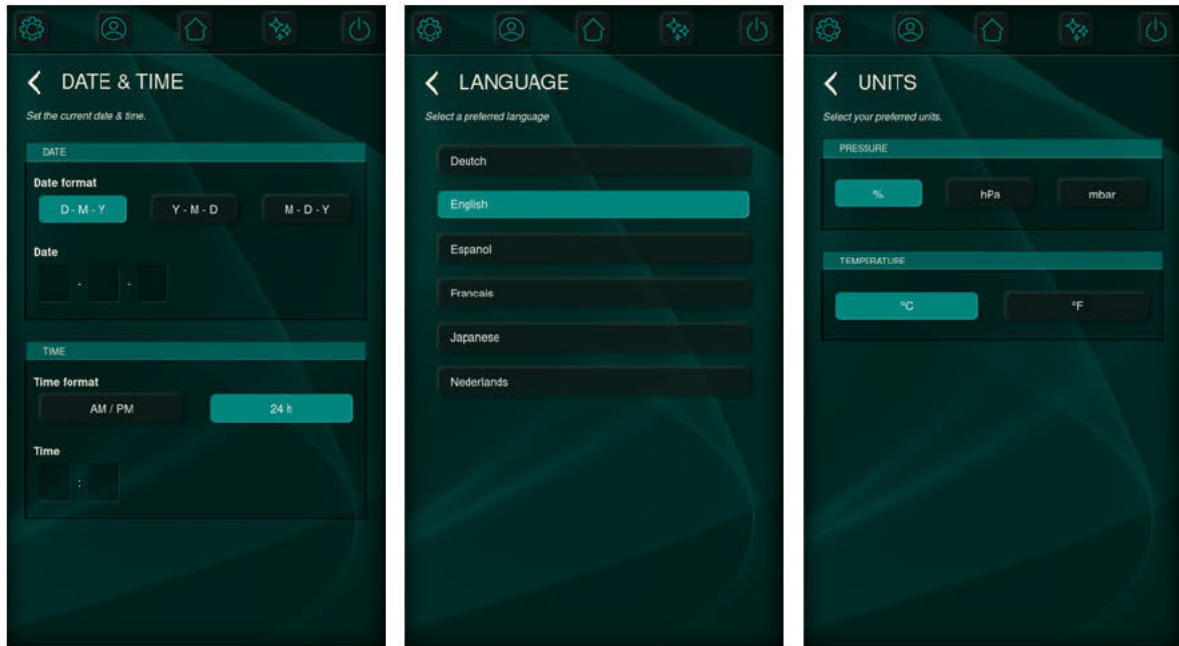

### 6.1.2.2.8 Configure display

Depending on the environment where the machine is used, a specific level brightness can be desired. The display configuration screen provides settings for:

- Brightness
- Inactivity-timer for dimming the display
- Inactivity timer for switching off the display
- Colour of the LED which shows the machine is in standby mode. The colour of this LED can be customized by selecting one of the four preset option

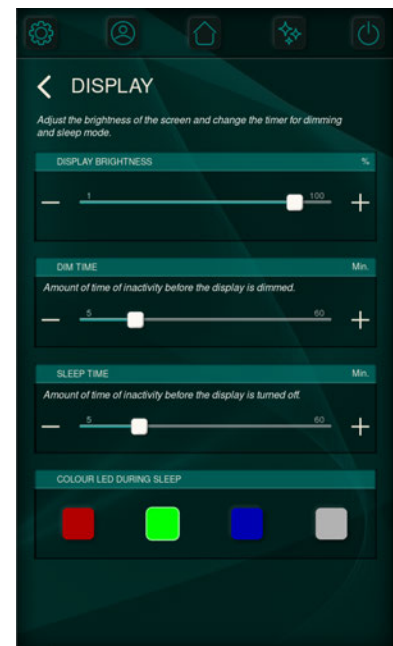

### 6.1.2.3 Maintenance & Service

The machine is equipped with multiple maintenance indicators to ensure its optimal performance. These indicators will signal when it's time to replace the oil, oil mist filter, or when the pump cleaning program should be initiated.

The underlying menus have the following information and settings available:

- When the last operation was done
- What the set interval is
- Reset the interval

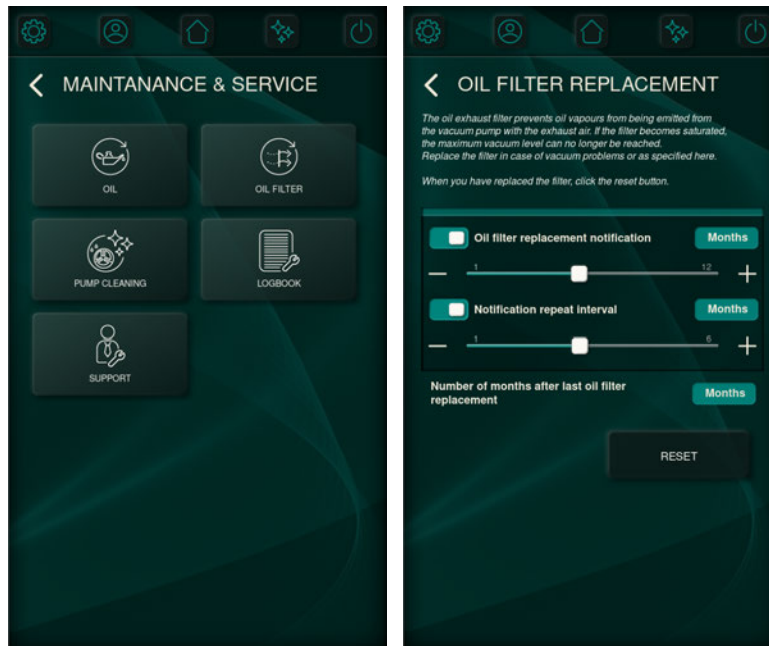

### 6.1.2.3.1 Logbook

A logbook has been integrated to aid service providers in managing service data. It contains a summary of maintenance cycles and recorded logs. Service providers can re users to share this logbook, which can be achieved by exporting the logs to a USB drive and forwarding them via email.

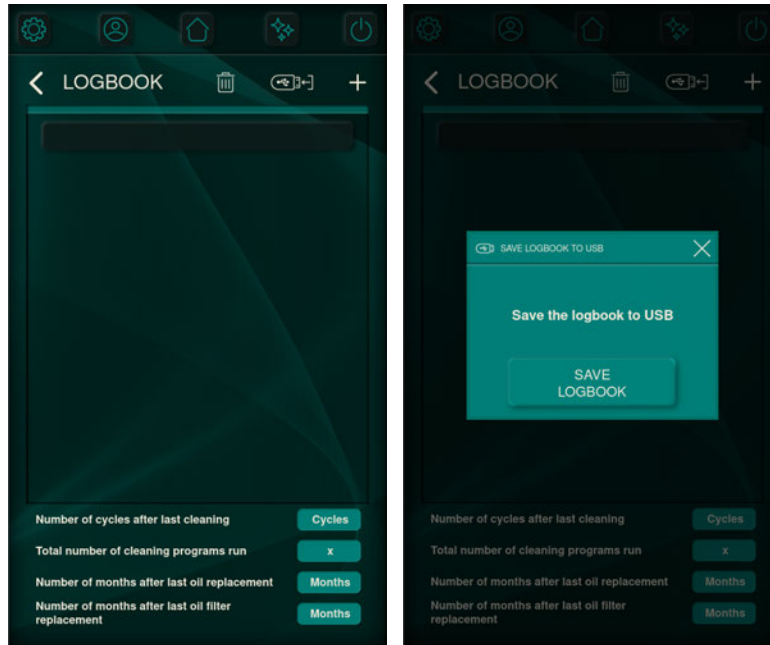

### 6.1.2.3.2 Support

If you require any assistance with the machine, the support menu offers the contact information for the dealer responsible for the installation or supply of the machine. Alternatively, you can scan the QR code to access the support website and access further information.

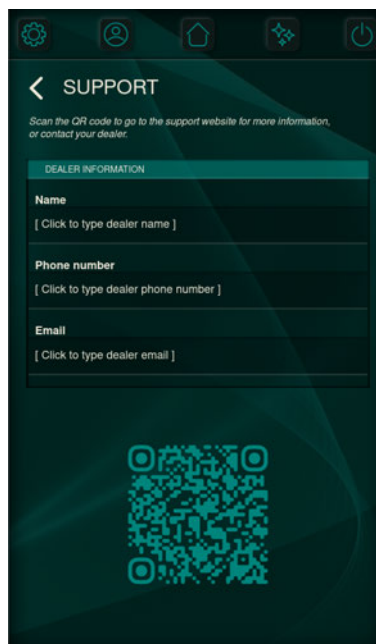

#### 6.1.2.4 Import & Export

By incorporating various import and export capabilities, machines can easily be upgraded to the latest standards. This combined with continuous improvements in the software -programs and functions, result in a better general user experience.

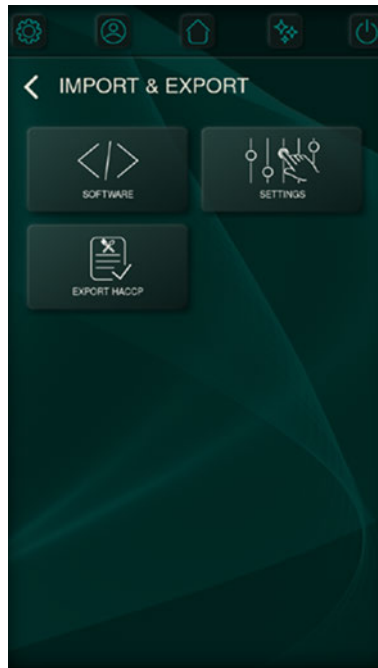

### 6.1.2.4.1 Software updates

Software updates are divided into two categories: GUI (Graphical User Interface) and firmware. Firmware is responsible for defining the operation and communication of the with hardware components, while the GUI dictates the visual interface and its interactions with various on-screen elements.

Current firmware and GUI versions are displayed on the screen, updating can be accomplished by inserting a USB drive containing the specific GUI or Firmware and then pressing the corresponding button.



#### 6.1.2.4.2 Import & Export settings

Settings define all things that are configurable, adjustable and that can be set. A settings file can consist of all settings, but can also consist of only some settings, like (some) product programs or contact details.

Importing and exporting settings allows quick and easy synchronization of machines. Inserting an USB and import/export will read/write the designated information.

Reset to factory settings will revert all manual set setting back to default.

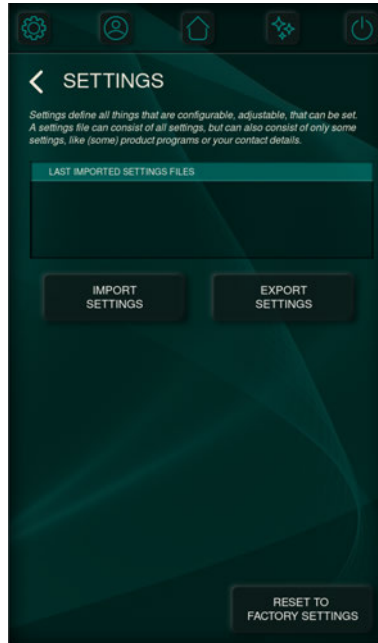

### 6.1.2.5 Test

A variety of tests have been integrated to identify malfunctions or evaluate the machine's condition. These tests range from a basic output test, leak assessment, to a comprehensive service analysis. These can:

- Reveal the presence and extent of machine leaks
- The final vacuum level and how long it takes to reach it
- The proper functionality of numerous hardware components

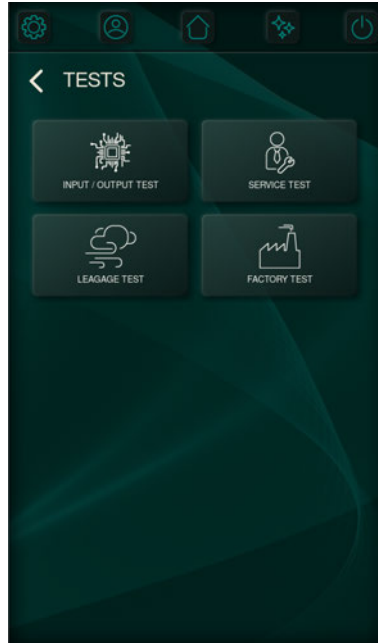

### 6.1.3 Switch user

The switch user menu can be accessed from the home screen as seen in chapter *Control Panel* on page 23

Access to relevant settings is granted based on the authorized level of the user that is signed in. The default Owner code is **1324**.

New user profiles can be defined, which is explained in chapter *User management* on page 29

User information is can be printed on the label and is stored for HACCP purposes

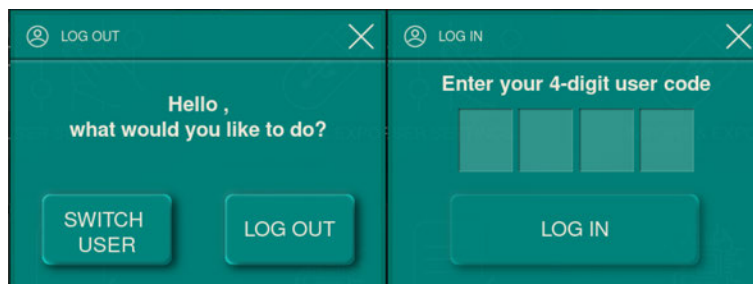

## 6.1.4 Basic operation

### 6.1.4.1 Starting the machine

1. Plug in the machine (see *Electrical Installation* on page 67). The display will light up and is ready for use.

When the vacuum pump needs to be cleaned, the machine shows the warning message “pump cleaning needed” after power on. Close the machine lid while the message is showing to immediately run the pump cleaning program. Refer to *Running the Pump Cleaning Program* on page 62

### 6.1.4.2 Starting the Packaging Cycle

The machine must be started in accordance with *Starting the machine* on page 43 before starting a packaging cycle.

1. Select the desired program.
2. Put the product/products in the vacuum bag.
3. Place the vacuum bag in/on the vacuum chamber. Make sure the opening(s) is/are correctly placed with regard to the seal position(s).
4. Close the lid.  
The packaging cycle will start.

### 6.1.4.3 During the vacuum cycle

When the lid is closed the vacuum cycle will start. The cycle can always be terminated by pressing the **STOP** button. Steps can be skipped/ended prematurely by pressing the **Next step** button.

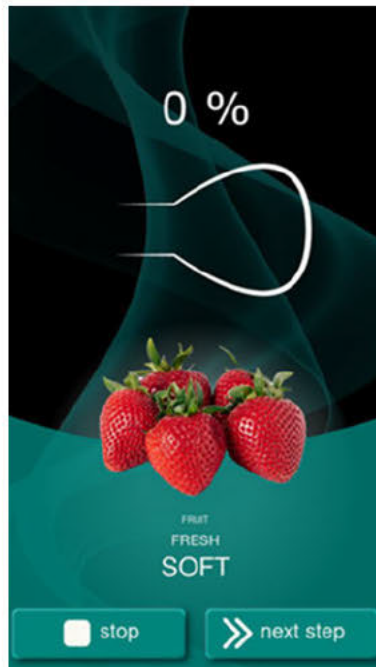

When packaging moisture-containing products, such as soups and sauces, it is important to closely monitor the vacuuming process. The moment bubbles are formed or the product starts to bubble, you should immediately proceed to the next step in the cycle. Enabling Liquid Control assists detecting the evaporation point and prevents spillage and dehydration.

## 6.1.5 External vacuum

The External Vacuum function allows special food containers to be vacuum extracted outside of the machine.



Check in advance whether the relevant gastronorm container can withstand and hold a vacuum.

To select the External Vacuum option, follow the steps below.

1. Select the **External Vacuum** program.
  2. Connect the external vacuum hose to the machine by placing the adapter over the suction inlet (1) in the vacuum chamber.
  3. To connect the external vacuum hose to the food container
    - a. Connect the external vacuum hose adapter (3) to the valve of the food container.
    - b. Slide the sliding valve (2) towards the hose (closed position).
  4. Press the **Start** button to start the vacuum cycle. The food container will be vacuum extracted.
  5. Slide the sliding valve of the adapter towards the gastronorm container (open position) and remove the external vacuum hose from the food container.
- Select the **External Vacuum** program. See *Function programs* on page 27.
  - Connect the external vacuum hose to the machine by placing the adapter over the suction inlet (1) in the vacuum chamber.
  - To connect the external vacuum hose to the food container:
    1. Connect the external vacuum hose adapter (3) to the valve of the food container.
    2. Slide the sliding valve (2) towards the hose (closed position).

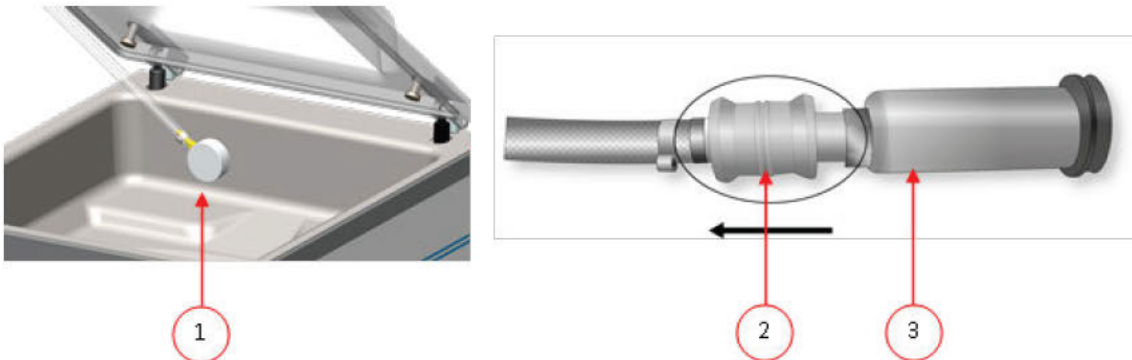

## 6.1.6 Guidelines for function values

For each function, values can be set if you are authorized as an owner. In order to understand the consequence of the set value, the table below explains the consequences of giving a low or high value for each function.

For the values in the table below, the following rule of thumb applies to setting a value in mbar. These values may vary slightly, depending on the humidity.

- 99% = 10 mbar
- 0% = 1013 mbar

Function	Range	Conditions
Vacuum	30 – 99.8%	Rule of thumb: the higher the vacuum, the less oxygen remains in the package and the longer the shelf life of the product. There are exceptions to this rule.
Vacuum+	0 – 60 seconds	This is the time the vacuuming will continue after the maximum vacuum has been reached. This to allow entrapped air to escape from the product. Please note that the vacuum must be set to the maximum.
Gas	30 – 98%	For some products it may be desirable to insert gas into the packaging to increase the shelf life of the product.
Gas+	0.1 – 1 second	For some products it may be desirable to insert additional gas into the packaging to create a "balloon packaging". This allows for a better protection of a fragile product. The recommended value for Gas+ is 0.7 seconds.
Red meat	0.1 – 1 second	When packaging large pieces of fresh meat, the product continues to degas during the sealing phase. Since the opening of the vacuum bag is already closed, air pockets may form inside the package after decompressing. This function prevents these air pockets.
Liquid control	30 – 99.8%	If the pressure is reduced, the boiling point of liquids will be decreased. As a result of this law of nature, a product may start boiling. In addition to contamination of the machine, this will reduce the weight and quality of the product to be packaged. By enabling the Liquid Control function, this special sensor will detect the evaporation point, and the program will stop vacuuming and proceed to the next step in the packaging process. The value that can be set is the maximum achievable vacuum value. Please keep in mind that this maximum vacuum value can only be achieved as long as the product does not start boiling.
LiquidControl+	0.1– 5 seconds	This is the time the vacuuming will continue after detection of the evaporation point. Because of the evaporation, a minor shock wave may occur, pushing all the remaining air from the bag. The best way to determine the right time is trial and error.
Sequential Vacuum	30 – 99.8%	If the value for the Vacuum+ time is insufficiently effective for the entrapped air to escape, the Sequential Vacuum can be enabled. In maximum five steps, vacuuming is alternated with maintaining time. Each step increases the vacuum reached in the previous step.

Function	Range	Conditions
Seal time	0.1-4.0 seconds	This is the time that the sealing wire and/or the cut-off wire are heated. The longer the time, _____ more heat is transferred to the bag.
Cleaning of the pump	15 minutes	Fixed value.



The vacuum in the chamber must be at least 30% at the moment of sealing.

If the pressure is reduced, the boiling point of liquids will be decreased (see *Vapour Pressure Curve of Water* on page 68). As a result, a product may start boiling. This can cause contamination of the machine, and will reduce the weight and quality of the product to be packaged.

When packaging moisture-containing products, such as soups and sauces, it is important to closely monitor the vacuuming process. If bubbles are forming or the product starts to boil, you should immediately proceed to the next step in the cycle. A higher vacuum can be achieved by letting products cool down sufficiently prior to starting the vacuuming process.

When packaging moisture-containing products, it is important to run the pump cleaning program at least once a week. When moisture-containing products are vacuumed on a daily basis, it is recommended to run the pump cleaning program at the end of every day.

## 6.2 Printer

A printer can be connected to the machine to print package labels.

### 6.2.1 Creating a Label

Labels can be added in the menus before starting any program. To add/edit labels press the Labels button and enter the desired information:

1. Customer name
2. Label number
3. Name
4. Info
5. Use by / Storage life
6. Storage temperature
7. Print customer name Y/N
8. Print info Y/N
9. Print achieved vacuum Y/N
10. Print expiry date Y/N
11. Print user Y/N
12. Print storage temperature Y/N

You can also select the number of labels you require per cycle. If you require an additional label after the complete cycle has ended and all labels have already been printed, select the **Print extra label** option. This will print the last printed label again.

## 6.2.2 Replacing a Printer Roll

Follow the steps below to place the label roll in the printer.



Despite the inner diameter of the label roll being bigger than the holder, the roll can be used without any issues.

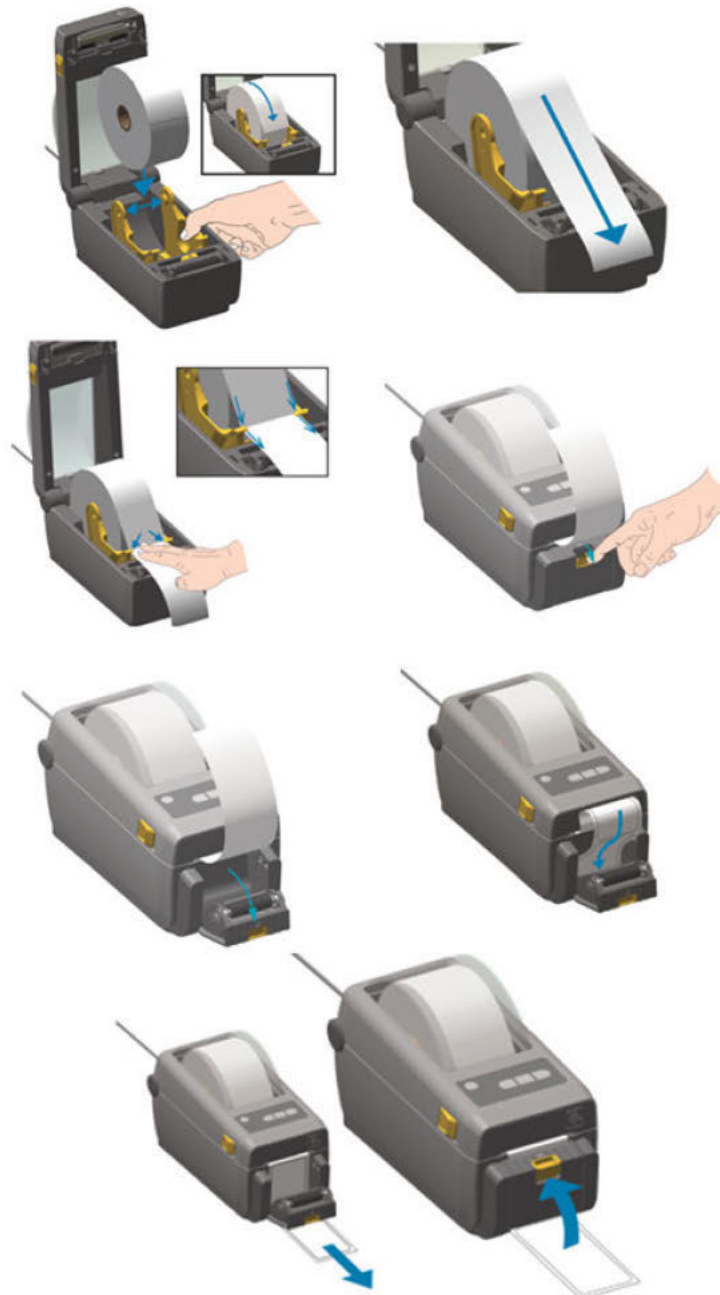

Figure 3: Replacing the Printer Roll

### 6.2.3 Aligning the Printer

1. Switch on the printer and make sure the indication light is green.
2. Press the **Pause** and **Cancel** button simultaneously for 2 seconds.

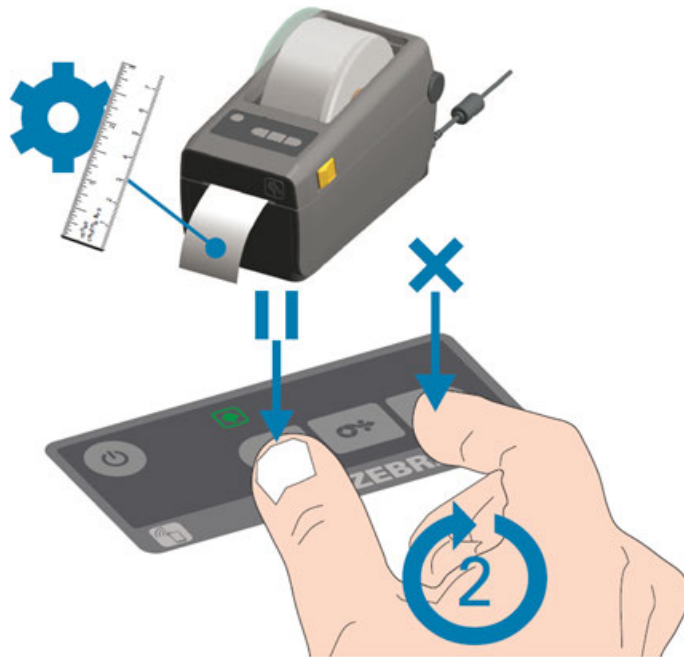

Figure 4: Aligning the Printer

The printer will print several labels and determine the correct position.

3. Press the **Feed** and **Cancel** button simultaneously for 2 seconds.

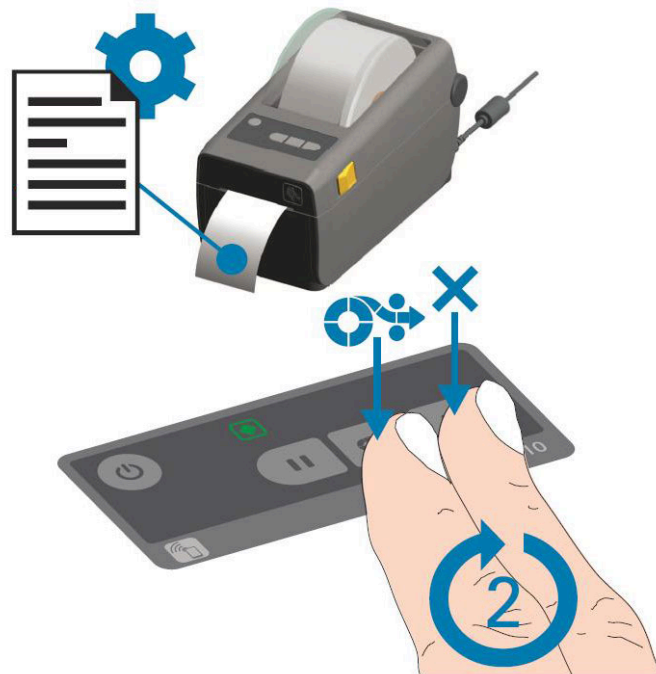

Figure 5: Printing the First Label

The printer will print the first label.

4. Remove the first printed label to print the next labels.

## 7 Maintenance

When carrying out maintenance work, always observe the following safety ru



- Always disconnect the power supply by disconnecting the plug.
- Always disconnect the gas supply (if applicable).



- Only trained technicians are authorised to perform the described maintenance activities.
- Test the machine after carrying out maintenance work or repairs to make sure the machine can be used safely.

### 7.1 Maintenance Schedule

The diagram below shows the maintenance activities that must be performed and the interval with which these activities must be performed.

For specific descriptions for performing maintenance activities, consult the appropriate section.

Activity *	1-D	1-W	1-M	6-M	1-Y	4-Y
<b>Cleaning</b>						
Cleaning the machine.	X					
<b>Inspections</b>						
Check the oil level.		X				
Run the pump cleaning program **.		X				
Inspect the sealing bars.		X				
Inspect the silicone rubber of the silicone holders.		X				
Inspect the lid gasket.		X				
Check the plastic lid for cracks (if applicable).		X				
Inspect the lid springs. Pay additional attention to damage and the fastenings of the lid springs.					X	
<b>Lubrication</b>						
Replace the oil of the vacuum pump. See <i>Technical Data</i> on page 66 for the type of oil.				X		

Activity *	1-D	1-W	1-M	6-M	1-Y	4-Y
<b>Replacement</b>						
Replace the sealing wires.				X		
Replace the silicone rubber of the silicone holders.				X		
Replace the lid gasket.				X		
Replace the oil exhaust filter.					X	
Contact your dealer for professional servicing.					X	
Replace the plastic lid (if applicable).						X

\* 1-D = Daily, 1-W = Weekly, 1-M = Every month, 6-M = Every 6 months, 1-Y = Annually, 4-Y = Every 4 years

\*\* In case of packing damp products this is not enough, then this should be done daily.

## 7.2 Cleaning the Machine



- Never clean the machine using a high pressure cleaner.
- Do not use any aggressive or toxic cleaning agents.
- Do not use any cleaning agents containing solvents.

Clean the surfaces with a soft, damp cloth. You can also apply a cleaning agent to the machine and wash it with clean water.

## 7.3 Replacing the Sealing Wire

Depending on the specifications of your machine, you can have one of the following (combinations of) sealing wires:

- Wide seal: one wide sealing wire
- Double seal: two sealing wires
- Trenn seal: one sealing wire and one cutting wire

The process of replacing the sealing wires is the same for all types.

Replace the sealing wires if the wire and/or the Teflon tape are damaged, or as specified in *Maintenance Schedule* on page 50.



Table 1: Removing the sealing bar

Table 2:

1. Remove the sealing bar by lifting it from the cylinders. See *Replacing the Sealing Wire* on page 51.

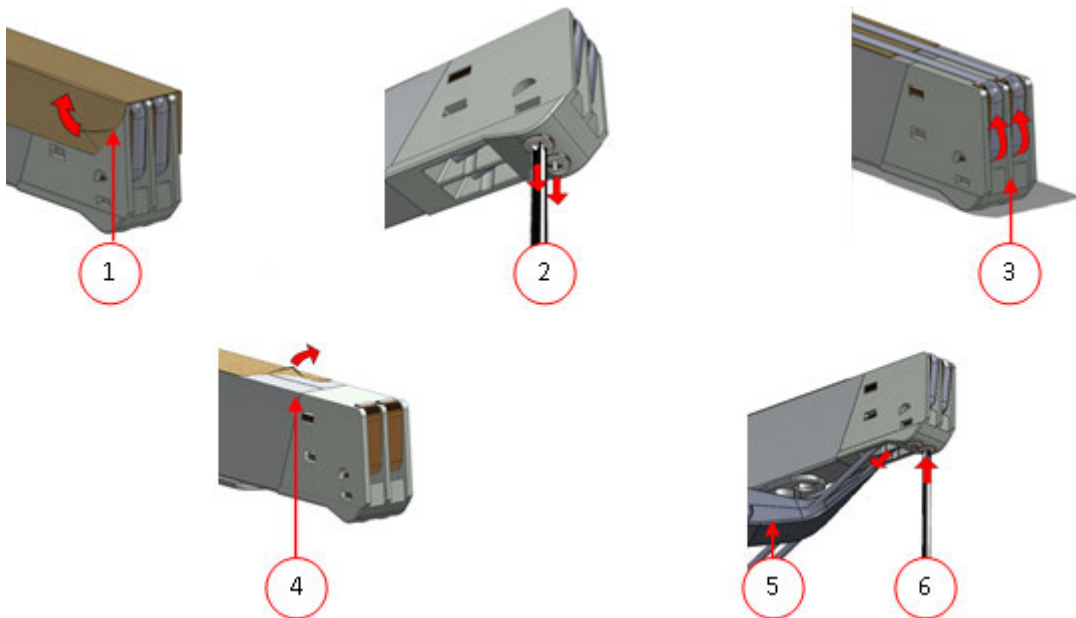

Figure 6: Replacing the Sealing Wire

2. Remove the Teflon tape (1) that protects the sealing wire.
3. Remove the screws (2) at the bottom of the sealing bar and remove the sealing wires (3).
4. Replace the Teflon tape on the sealing bar.
  - a. Pull the Teflon tape from the top of the sealing bar (4).

- b. Clean the sealing bar with a dust-free cloth.
- c. Apply a new piece of Teflon tape of the same length on the sealing bar.
5. Replace the sealing wires.
  - a. Cut a new piece of sealing wire or cutting wire at the length of the sealing bar plus approximately 15 cm.
  - b. First place the wire on one side of the sealing bar by tightening the screws (2).
  - c. Place the other end of the wire in its location and tension it with pliers. Now fasten it by tightening the screws.
  - d. Cut both ends of the wire.
6. Replace the Teflon tape on the sealing wire.
  - a. Cut a piece of Teflon tape at the length of the sealing bar plus approximately 5 cm.
  - b. Attach the tape over the sealing wires on the sealing bar evenly and without folds.
  - c. Cut the tape.
7. Place the sealing bar back in its position.

## 7.4 Replacing the Silicone Rubber of the Silicone Holders

To ensure a seal of good quality, the silicone rubber may not be damaged and the surface must be smooth. Mechanical contact or burning by the sealing wire may damage the rubber.

Replace the silicone rubber if damaged or as specified in *Maintenance Schedule* on page 50.

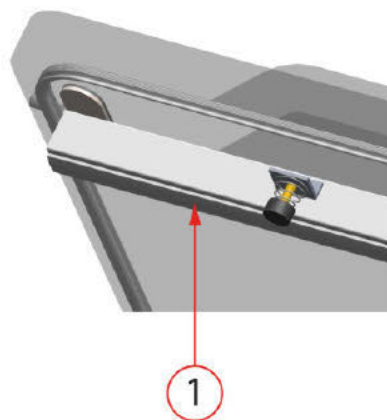

*Figure 7: Replacing the Silicone Rubber of the Silicone Holders*

1. Pull the old silicone rubber from the holder, see *Figure 7: Replacing the Silicone Rubber of the Silicone Holders* on page 53.
2. Cut a new piece of silicone rubber. Make sure it is the same length as the holder.



If the rubber is too short or too long, this may cause problems with the seal of the bag.

3. Install the new piece of silicone rubber by pressing it into the recess of the silicone holder.

Ensure that the silicone rubber is fully and uniformly placed in the recess. It is also important that the surface of the silicone rubber is smooth after it is in place, and that it shows no signs of stress.

## 7.5 Replacing the Lid Gasket

The lid gasket ensures the vacuum chamber is fully closed during the machine cycle. This is essential to reach the maximum vacuum level. Due to extreme pressure differences, the gasket wears and should therefore be replaced regularly.

Replace the lid gasket if damaged or as specified in *Maintenance Schedule* on page 50.

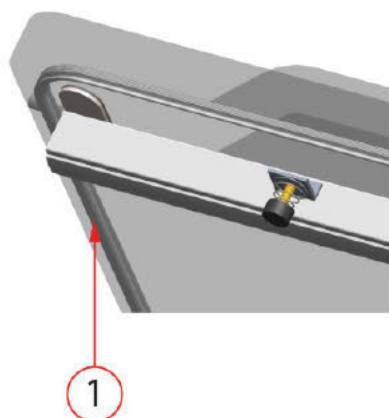

Figure 8: Replacing the Lid Gasket

1. Pull the old gasket loose to remove it.
2. Cut a new piece of rubber.



Preferably cut the new piece of rubber slightly longer than the old piece.

The edges must be cut straight.



If the lid gasket is too short or too long, this may cause problems when closing the lid or it may cause leakage.

3. Install the new gasket by pressing it into the gasket slot. The lip of the gasket must face downwards and outwards.

The gasket should be placed in the slot evenly and without any tension. The edges must be placed closely together to prevent leakage.

## 7.6 Inspecting the Lid Springs

1. Check the fastenings of the lid springs for wear, corrosion and damage.
2. Check the lid springs for wear and damage.



In the case of leakage, please contact your service dealer.

## 7.7 Vacuum Pump maintenance

The vacuum pump creates the vacuum. Regular maintenance of the pump is very important.

### 7.7.1 Overview

Depending of the configuration the machine is equipped with one of the following pumps:

#### 7.7.1.1 Busch pump 8 m<sup>3</sup>/h

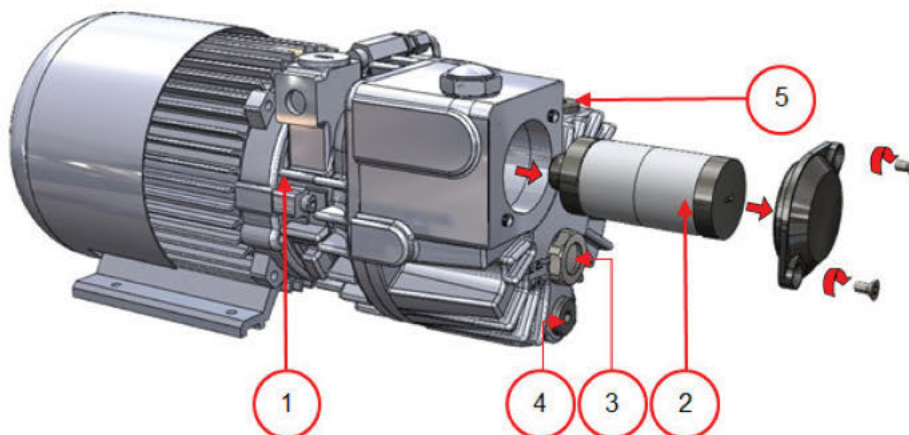

Figure 9: Overview of the Busch pump

1. **Vacuum pump** - Creates the vacuum for the process.
2. **Oil exhaust filter** - Filters the air by capturing oil vapours.
3. **Oil sight glass** - Indicates the maximum and minimum oil levels of the vacuum pump.
4. **Oil drain plug** - Removing the oil drain plug allows the oil to be drained.
5. **Oil filler plug** - Removing the oil filler plug allows the oil to be refilled.

### 7.7.1.2 Busch pump 16 - 21 m<sup>3</sup>/h

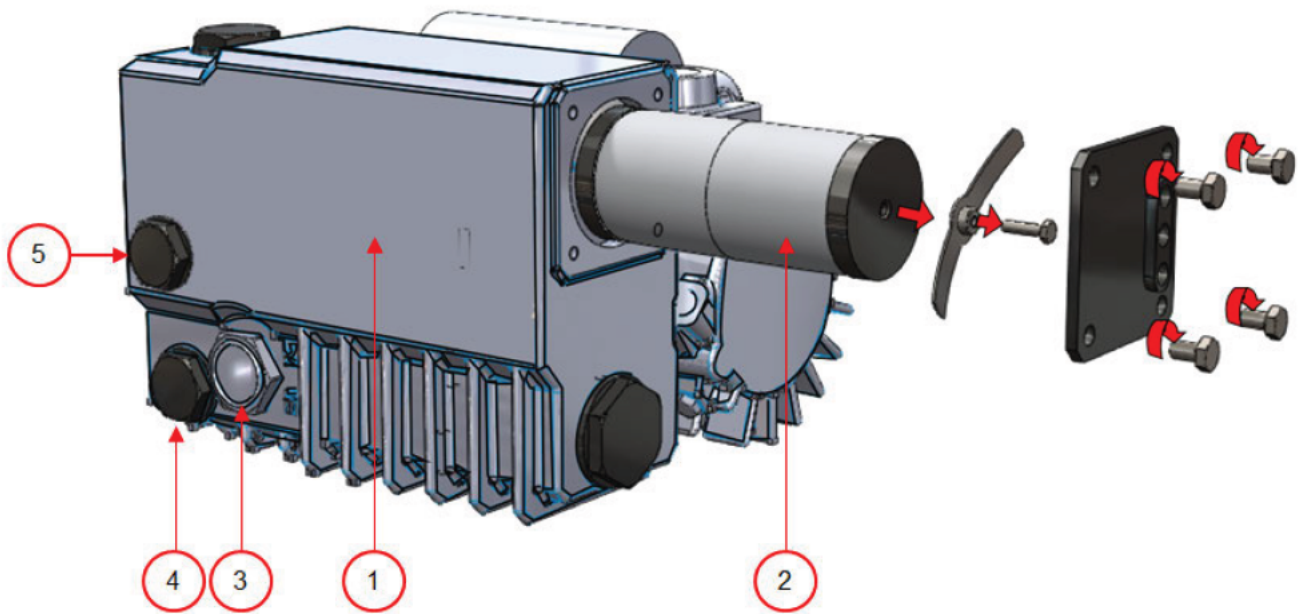

Figure 10: Overview of the Busch pump

1. **Vacuum pump** - Creates the vacuum for the process.
2. **Oil exhaust filter** - Filters the air by capturing oil vapours.
3. **Oil sight glass** - Indicates the maximum and minimum oil levels of the vacuum pump.
4. **Oil drain plug** - Removing the oil drain plug allows the oil to be drained.
5. **Oil filler plug** - Removing the oil filler plug allows the oil to be refilled.

### 7.7.1.3 Becker pump 16 - 21 m<sup>3</sup>/h

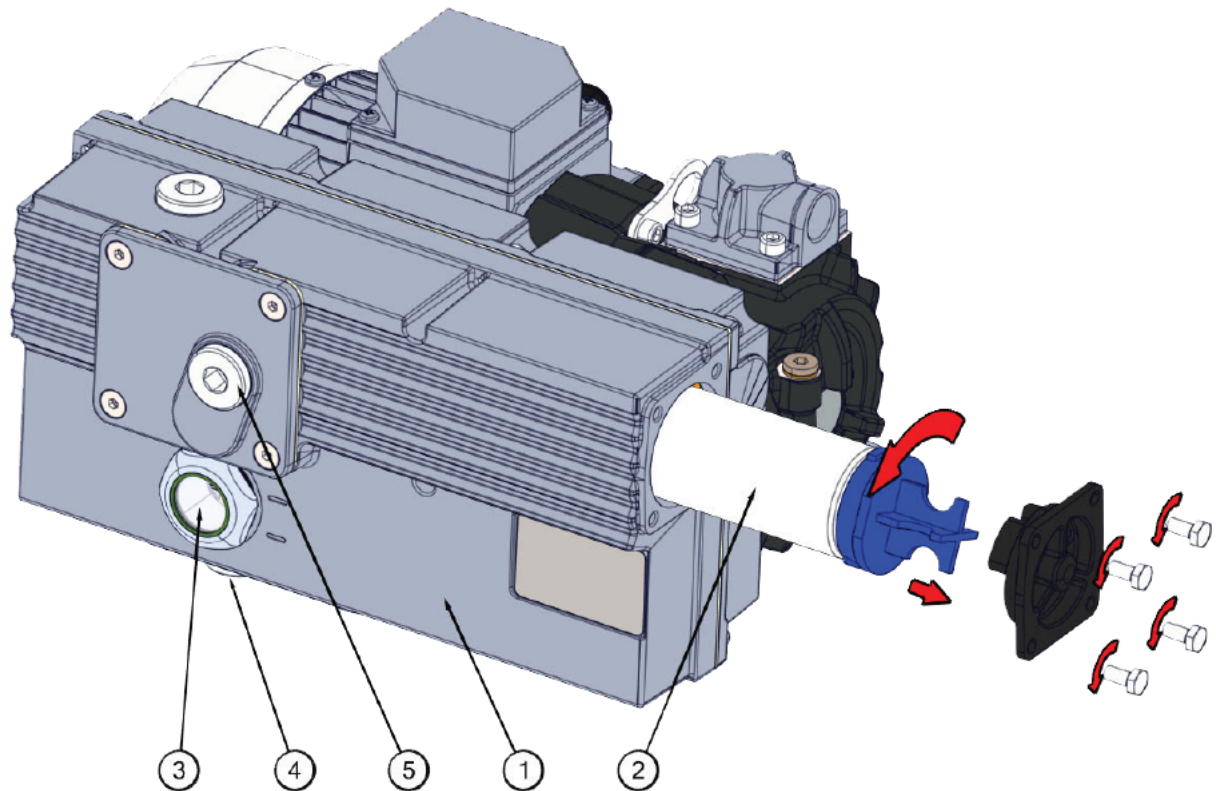
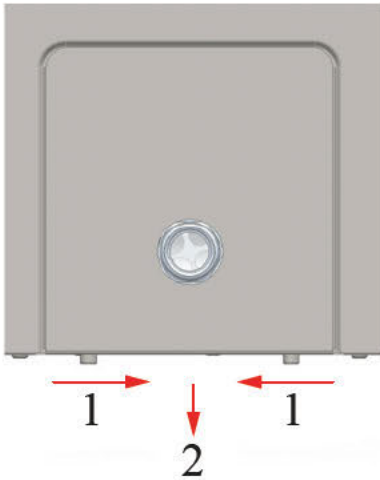

Figure 11: Overview of the Becker pump

1. **Vacuum pump** - Creates the vacuum for the process.
2. **Oil exhaust filter** - Filters the air by capturing oil vapours.
3. **Oil sight glass** - Indicates the maximum and minimum oil levels of the vacuum pump.
4. **Oil drain plug** - Removing the oil drain plug allows the oil to be drained.
5. **Oil filler plug** - Removing the oil filler plug allows the oil to be refilled.

## 7.7.2 Service hatch

A maintenance hatch can be found on the side of the machine. When the two protruding heads are slid towards each other followed by a downward sliding motion the hatch is removed, revealing the oil fill and drain openings of the pump.



## 7.7.3 Removing Oil, Refilling Oil

This section describes how to remove oil from the pump and how to refill the oil.

See *Overview* on page 55 for the pump fitted in the machine and an overview of the parts.



The oil in the vacuum pump may be hot. Avoid contact with hot oil when removing the oil.



The use of Personal protection Equipment with the corresponding CE marking is recommended.

If the machine remains unused for a prolonged period of time, the oil must be removed from the pump. This is necessary because moisture and dirt in the oil may affect the pump, causing the pump to jam at the next use.

Follow the steps below to remove the oil from the pump:

1. Place a drip pan under the oil drain plug.
2. Remove the oil drain plug.  
The oil will drain from the pump.
3. Replace the oil drain plug.

Follow the steps below to add oil to the pump. You can follow these steps after all oil has been removed, but also to refill oil.

4. Remove the oil filler plug.
5. Add oil until the oil level is between the minimum and maximum levels of the oil sight glass.
6. Replace the oil filler plug.

## 7.7.4 Replacing the Oil Exhaust Filter



The use of Personal protection Equipment with the corresponding CE marking is recommended.

The oil exhaust filter prevents oil vapours from being emitted from the vacuum pump with the exhaust air. If the filter becomes saturated, the maximum vacuum level can no longer be reached. Replace the filter in case of vacuum problems or as specified in *Maintenance Schedule* on page 50.

### 7.7.4.1 Busch pump 8 m<sup>3</sup>/h

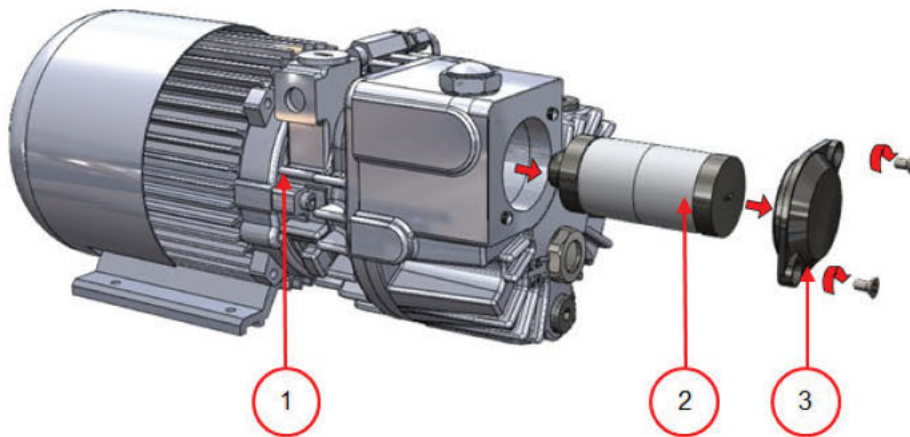

Figure 12: Replacing the Oil Exhaust Filter

Follow the steps below to remove the old oil exhaust filter:

1. Remove the filter cover (3) of the vacuum pump (1) and put it aside.
2. Remove the oil exhaust filter (2) from the vacuum pump.

Follow the steps below to install a new oil exhaust filter:

3. Turn the new filter into the vacuum pump.  
Make sure the O-ring is properly placed on the filter inlet.
4. Mount the filter cover placed aside.

### 7.7.4.2 Busch pump 16 - 21 m<sup>3</sup>/h

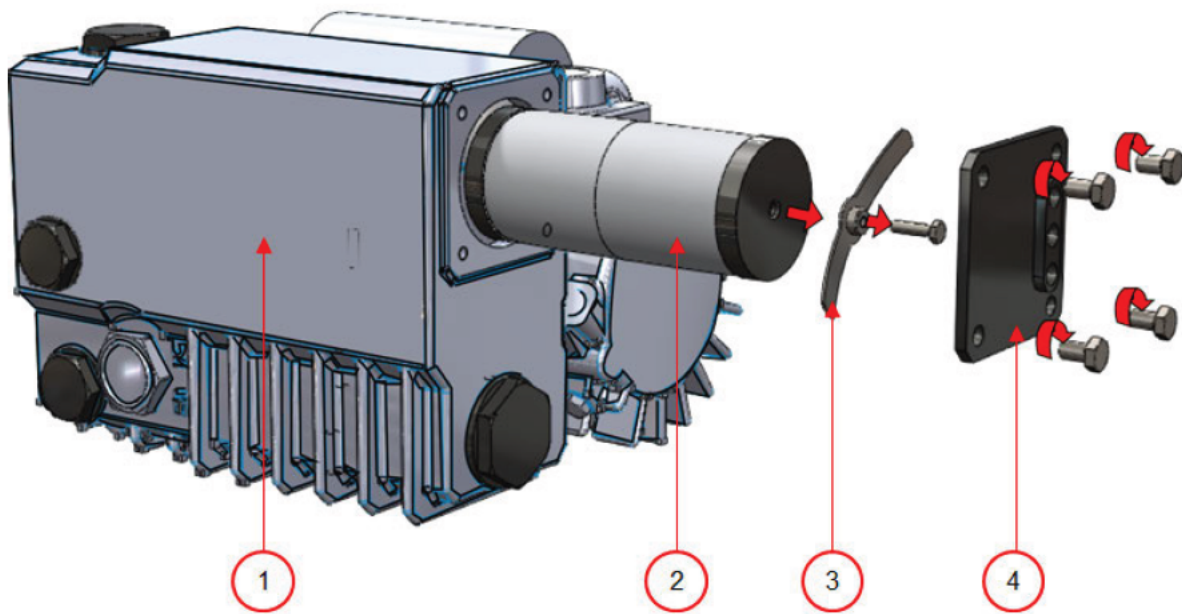

Figure 13: Replacing the Oil Exhaust Filter

Follow the steps below to remove the old oil exhaust filter:

1. Remove the filter cover (4) of the vacuum pump (1) and put it aside.
2. Remove the leaf spring (3) and put it aside.
3. Remove the old filter (2).

Follow the steps below to install a new oil exhaust filter:

4. Insert the new filter into the vacuum pump.  
Make sure the O-ring is properly placed on the filter inlet.
5. Mount the leaf spring placed aside.
6. Mount the filter cover placed aside.

### 7.7.4.3 Becker pump 16 - 21 m<sup>3</sup>/h

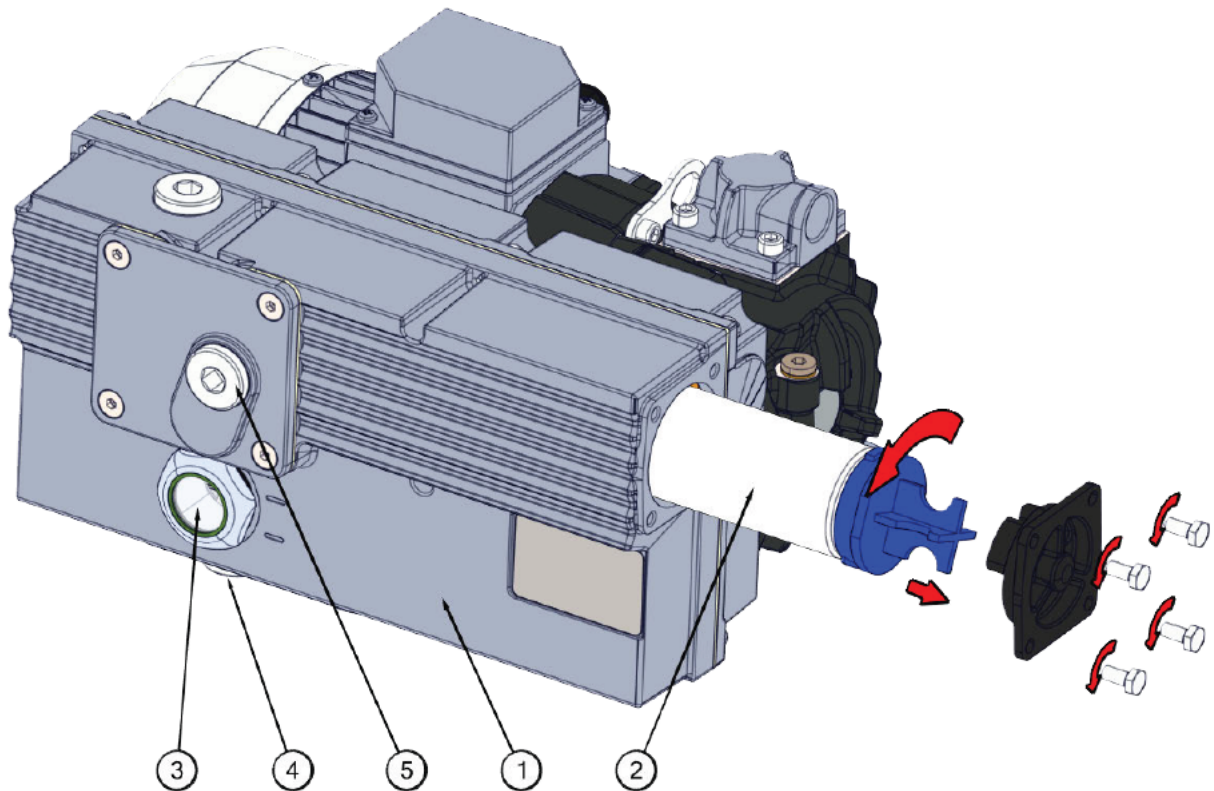

Figure 14: Replacing the Oil Exhaust Filter

Follow the steps below to remove the old oil exhaust filter:

1. Loosen the four screw (3) holding the filter cover (4) and remove the cover.
2. Turn the old filterer (2) 90° counter clockwise and pull it out of the pump housing (1).
3. Place the old filter in a suitable container to prevent any spilling.

Follow the steps below to install a new oil exhaust filter:

4. Insert the new filter into the vacuum pump.
5. Turn the filter 90° clockwise until it snaps into place.
6. Mount the filter cover and tighten the four screws.

Make sure the O-ring is properly placed.

## 7.7.5 Running the Pump Cleaning Program

The pump cleaning program runs the vacuum pump for 15 minutes. During the program, the pump and the oil reach the operating temperature. Moisture in the pump is absorbed by the oil. The high temperature causes any moisture in the pump to evaporate, and minimises the risk of corrosion.

It is advisable to run the program before using the machine for the first time, after the machine has been stationary for a lengthy period of time, and especially prior to changing oil.

Run the pump cleaning program every week. If you package moisture-containing products, such as soups and sauces, the pump cleaning program should be run every day.

1. Select the pump cleaning program.

Press the **Pump cleaning** button (8). When this button is pressed a dialog pop up with information about the pump conditioning cycle. The cycle can be started from this position by closing the lid.



2. Close the lid to start the pump cleaning program.  
The pump cleaning program will run for 15 minutes.

## 8 Troubleshooting and Error Codes

The tables below show the possible malfunctions and the corresponding causes as well as the steps to be taken.

Malfunction	Activity	More information
Control panel does not illuminate.	<ul style="list-style-type: none"> <li>Connect the machine to the power supply.</li> </ul>	<p><i>Connecting the Machine</i> on page 20</p> <p><i>Electrical Installation</i> on page 67</p>
The control panel is on, but there is no activity after closing the lid.	<ul style="list-style-type: none"> <li>Check or adjust the switch of the lid.</li> </ul>	Contact your supplier.
Insufficient end vacuum.	<ul style="list-style-type: none"> <li>Check the vacuum settings of the program and adjust them.</li> <li>Make sure that the extraction opening is not covered.</li> <li>Check the oil level in the pump.</li> <li>Check/replace the oil exhaust filter.</li> <li>Check/replace the lid gasket.</li> </ul>	<p><i>Operation</i> on page 22.</p> <p><i>Vacuum Pump maintenance</i> on page 55.</p> <p><i>Replacing the Oil Exhaust Filter</i> on page 59.</p> <p><i>Replacing the Lid Gasket</i> on page 54.</p>
Vacuum process is slow.	<ul style="list-style-type: none"> <li>Make sure that the extraction opening is not covered.</li> <li>Check the oil level in the pump.</li> <li>Check/replace the oil exhaust filter.</li> </ul>	<i>Replacing the Oil Exhaust Filter</i> on page 59.

Malfunction	Activity	More information
Vacuum bag is not sealed correctly.	<ul style="list-style-type: none"> <li>• Pull the sealing bar out of the machine and clean the contact surfaces in the mounting holes of the sealing bar.</li> <li>• Check the seal settings of the program and adjust them.</li> <li>• Check/replace the Teflon tape and the sealing wires.</li> <li>• Check/replace the silicone rubber of the silicone holders.</li> <li>• Check the inside of the vacuum for contamination and clean it.</li> </ul>	<p><i>Operation</i> page 22.</p> <p><i>Replacing the Sealing Wire</i> on page 51.</p> <p><i>Replacing the Silicone Rubber of the Silicone Holders</i> on page 53.</p>

## Error messages

Malfunction	Activity	More information
Cycle aborted!	<ul style="list-style-type: none"> <li>• Check whether the lid is open.</li> <li>• Close the lid.</li> </ul>	Do not open the lid before the program is finished.
Pressure sensor failure!	<ul style="list-style-type: none"> <li>• Check whether the sensor is connected.</li> </ul>	In case the malfunction reoccurs, contact your supplier.
Pump cleaning needed!	<ul style="list-style-type: none"> <li>• Run the pump cleaning program.</li> </ul>	Start the pump cleaning program by closing the lid. The program takes 15 minutes.
Oil change needed!	<ul style="list-style-type: none"> <li>• A service check is needed.</li> </ul>	<p>Activity: A service check is needed</p> <p>For more information: contact your supplier</p>

## 9 Disposal



Do not dispose of oil and components as household waste. When replacing oil or components at the end of the service life, ensure that all materials are collected and disposed or reused in a legal and environmentally sound manner.

## 10 Appendices

### 10.1 Technical Data

#### 10.1.1 Aura series

Aura	35	35+	42	42+	42XL	42XL+
<b>General</b>						
Ambient temperature during operation	5 to 30°C	5 to 30°C	5 to 30°C	5 to 30°C	5 to 30°C	5 to 30°C
Machine working conditions: relative humidity (non-condensing)	10-90%	10-90%	10-90%	10-90%	10-90%	10-90%
Sound emission	< 70 dB(A)	< 70 dB(A)	< 70 dB(A)	< 70 dB(A)	< 70 dB(A)	< 70 dB(A)
Maximum daily production	5 hrs/day	5 hrs/day	5 hrs/day	5 hrs/day	5 hrs/day	5 hrs/day
<b>Dimensions of the machine</b>						
Width	451 mm	451 mm	491 mm	491 mm	491 mm	491 mm
Length	543 mm	543 mm	523 mm	523 mm	613 mm	613 mm
Height	454 mm	454 mm	464 mm	464 mm	469 mm	469 mm
Weight	36 kg	41 kg	57 kg	61 kg	68 kg	72 kg
<b>Maximum product height</b>	150 mm	150 mm	180 mm		180 mm	
<b>Electrical connection</b>						
Supply voltage	*	*	*	*	*	*
Connected load	*	*	*	*	*	*
<b>Vacuum pump</b>						
Capacity	8 m <sup>3</sup> /h	16 m <sup>3</sup> /h	16 m <sup>3</sup> /h	21 m <sup>3</sup> /h	16 m <sup>3</sup> /h	21 m <sup>3</sup> /h
Oil	0.25 litre	0.3 litre	0.3 litre	0.5 litre	0.3 litre	0.5 litre
Type of synthetic oil	Foodmax Air 32	Foodmax Air 32	Foodmax Air 32	Foodmax Air 32	Foodmax Air 32	Foodmax Air 32
Ambient temperature synthetic oil	-10 to 40°C**	-10 to 40°C**	-10 to 40°C**	-10 to 40°C**	-10 to 40°C**	-10 to 40°C**

\*See machine plate.

\*\*For different temperatures, please contact your dealer.

## 10.2 Electrical Installation

The electrical installation provides power for the vacuum pump, the seal system and the operation of the machine.

See the electrical diagram for the further structure and operation of the electrical installation. Please contact your supplier for the electrical diagram.



Only a technical expert may perform work on the electrical installation.

The machine consists of the following electrical components:



Figure 15: Overview of the Electrical Installation

### 1. Power connection

This serves to connect the machine to the power supply.

### 2. Control panel

This serves to operate the control functions. Your machine has the following control option:

- *Aura Control System* on page 23

## 10.3 Vapour Pressure Curve of Water

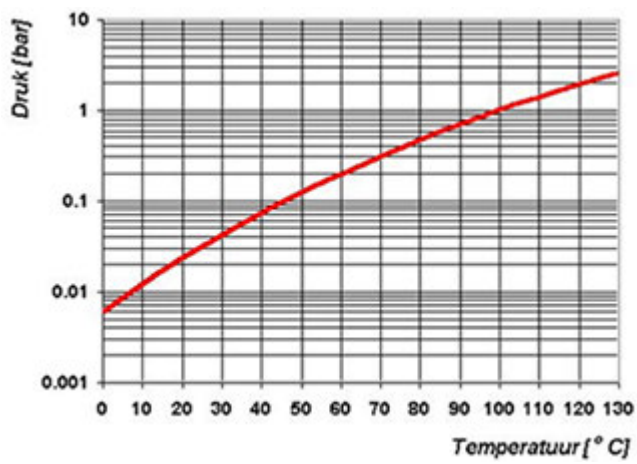

Figure 16: Vapour Pressure Curve of Water

