

09/2016

Mod: SDGT/10-CL

Production code: 646572



Diamond
catering equipment

Convection Oven Natural Gas Convection Oven 10GN 1/1

ITEM # _____

MODEL # _____

NAME # _____

SIS # _____

AIA # _____



Convection Oven

Natural Gas Convection Oven 10GN 1/1

646572 (HOR101GKG)

10 1/1 GN grids Convection oven, gas, with high resolution touch screen control, direct steam (humidifier with 11 settings), 2 cooking modes (manual, recipe program) and automatic cleaning system functions

Short Form Specification

Item No.

10GN 1/1 gas convection oven performs all of the functions of a convection oven and has a boilerless steaming function to add and retain moisture for high quality, consistent cooking cycles. Cooking modes include a convection (hot air) cycle (25° C-300°C) with an automatic moistener with 11 settings from zero to high moisture, programmability to save recipes, automatic pre-heating, a hold function and automatic rapid cooling. All 304 Stainless steel construction, seamless hygienic cooking chamber with all rounded corners. Double thermo-glazed door with open frame construction for cool outside door panel. IPX5 spray water protection certification. Features USB connection, HACCP management.

Automatic and built-in self cleaning system with Economizer functions to save energy, water and rinse aid.

Main Features

- Dry hot convection cycle (max 300 °C) ideal for low humidity cooking. Automatic moistener (11 settings) for boiler-less steam generation:
 - 0 = no additional moisture (browning, au gratin, baking, pre-cooked food)
 - 1-2 = low moisture (small portions of meat and fish)
 - 3-4 = medium low moisture (large pieces of meat, reheating, roasted chicken and proving)
 - 5-6 = medium moisture (roasted vegetable and first step of roasted meat & fish)
 - 7-8 = medium-high moisture (stewed vegetables)
 - 9-10 = high moisture (poached meat and jacket potatoes)
- Programmability: up to 1000 recipes can be stored in the oven's memory to replicate the same recipe at all times. Includes also 16-step cooking programs.
- Variable fan speed (radial fan): full speed, half speed and pulse ventilation available.
- Hold function for keeping food warm at the end of a cycle.
- Automatic and manual rapid cooling activation when going from a higher to a lower temperature.
- MultiTimer function to manage a sequence of up to 14 different cooking cycles, improving flexibility and ensuring excellent cooking results. Can be saved up to 70 multitimers programs.
- HACCP data management
- USB connection: to download HACCP and FSC data, upload the recipes and interface setting.
- Single sensor core temperature probe included.
- Make-it-mine feature to allow user to personalize all user main interfaces in the "Setting" mode and block editing and deleting of stored programs.
- Supplied with n.1 tray rack 1/1GN, 65 mm pitch.
- Automatic cleaning system: 4 different pre-set cycles to clean the cooking cell, according to the actual requirements. The cleaning system is built-in (no need for add-ons).
- Perfect evenness: blows fresh air from the outside through the bi-functional fan, which pushes the air that has been preheated in the meantime, into the cooking chamber, guaranteeing the evenness of the cooking process.

Construction

- IPX 5 spray water protection certification for easy cleaning.
- 304 AISI stainless steel construction throughout.
- Seamless hygienic cooking chamber with all rounded corners for easy cleaning.
- Swing hinged front panel for easy service access to main components.
- Double thermo-glazed door with open frame construction, for cool outside door panel. Swing hinged easy-release inner glass on door for easy cleaning.

APPROVAL: _____

Optional Accessories

- EXHAUST HOOD WITHOUT FAN F. 6&10GN1/1- PNC 640791
LW
- EXHAUST HOOD WITH FAN FOR 6&10 GN1/1- PNC 640792
LW
- WATER SOFTNER WITH CARTRIDGE C500 PNC 920002
- WATER SOFTENER WITH CARTRIDGE STEAM PNC 920003
1200
- AUTOMATIC WATER SOFTENER FOR OVENS PNC 921305
- RESIN SANITIZER FOR WATER SOFTENER PNC 921306
- WHEEL KIT FOR BASE OF 6&10X1/1 & 2/1 LW PNC 922003
- TROLLEY FOR SLIDE-IN RACK 6&10X1/1GN PNC 922004
- TRAY RACK+WHEELS 10X1/1GN, 65MM PITCH PNC 922006
- TRAY RACK+WHEELS 8X1/1GN, 80MM PITCH PNC 922009
- KIT 4 ADJUSTABLE FEET PNC 922012
- THERMAL COVER FOR 10X1/1GN-LW PNC 922013
- BANQUET RACK-30PLATES-65MM PNC 922015
PITCH-10GN1/1
- PAIR OF 1/1GN AISI 304 S/S GRIDS PNC 922017
- TRAY SUPPORT FOR 6&10 GN1/1 OVEN PNC 922021
BASES
- 2 GRIDS GN 1/1 FOR CHICKENS (8 PER GRID) PNC 922036
- PASTRY 8X(400X600)RACK+ PNC 922066
WHL-80MM,10X1/1
- BANQUET RACK-23PLATES-85MM PNC 922071
PITCH-10GN1/1
- SLIDE-IN RACK+HANDLE FOR 6&10 GN1/1- PNC 922074
LW
- 1 GRID GN1/2 FOR 4 WHOLE CHICKENS PNC 922086
(1.2KG)
- TRAY RACK+REINF.10X1/1GN, 64MM PITCH- PNC 922099
LW
- EXTERNAL CONN. KIT FOR DETERG./RINSE PNC 922169
AID
- RETRACTABLE HOSE REEL SPRAY UNIT PNC 922170
- EXTERNAL SIDE SPRAY UNIT PNC 922171
- FAT FILTER FOR OVENS 10X1/1-2/1 PNC 922178
- TRAY(400X600X38)5 ROWS-PERF.ALUM/ PNC 922189
SILICON
- BAKING TRAY(400X600X20)4 EDGES-PERF. PNC 922190
ALUM
- BAKING TRAY(400X600X20)4 EDGES- PNC 922191
ALUMINIUM
- OPEN BASE+TRAY SUPPORT 6&10X1/1GN LW PNC 922195
- BASKET FOR DETERGENT TANK-WALL PNC 922209
MOUNTED
- HOLDER FOR DETERGENT TANK ON OPEN PNC 922212
BASE
- CUPB. BASE+TRAY SUPP-6&10 GN1/1 OVENS PNC 922226
LW
- FLUE CONDENSER FOR GAS OVENS-LW PNC 922235
- 2 FRYING BASKETS FOR OVENS PNC 922239
- HEAT SHIELD FOR STACKED OVEN 6GN ON PNC 922245
10GN
- CONTROL PANEL FILTER-6&10 GN1/1 OVENS- PNC 922246
LW
- HEAT SHIELD FOR 10 GN 1/1 OVENS PNC 922251
- DOUBLE-CLICK CLOSING CATCH FOR OVEN PNC 922265
DOOR
- 1 GRID GN1/1 FOR 8 WHOLE CHICKENS PNC 922266
(1.2KG)
- KIT INTEGRATED HACCP FOR OVENS PNC 922275
- KIT TO CONVERT FROM NATURAL GAS TO LPG PNC 922277
- USB PROBE FOR SOUS-VIDE COOKING PNC 922281
- DRAIN KIT (D=50MM) OVENS 6&10 GN 1/1-2/1 PNC 922283
- PASTRY RUNNERS (400X600) 6&10GN1/1 BASES PNC 922286
- GREASE COLLECTION KIT (TRAY+TROLLEY) PNC 922287
- BAKING TRAY FOR BAGUETTE GN 1/1 PNC 922288
- EGG FRYER FOR 8 EGGS - GN 1/1 PNC 922290
- KIT BAKERY RACK FOR 10 GN1/1 OVENS PNC 922292
- FLAT BAKING TRAY WITH 2 EDGES-GN 1/1 PNC 922299
- POTATO BAKER GN 1/1 FOR 28 POTATOES PNC 922300
- STACKING KIT-GAS 6X1/1 ON GAS 6&10X1/1 PNC 922318
- KIT FLANGED FEET PNC 922320
- GREASE COLLECTION TRAY 100 MM PNC 922321
- TROLLEY FOR MOBILE RACK STACKED OVEN PNC 922323
- UNIVERSAL SKEWER RACK PNC 922326
- 4 LONG SKEWERS PNC 922327
- GREASE COLLECTION TRAY 40 MM PNC 922329
- WHEELS FOR STACK.2X6GN1/1-6GN1/1+10GN1/1 PNC 922333
- SMOKER FOR LW/CW OVENS PNC 922338
- CHIMNEY ADAPTOR PNC 922346
- KIT CHECK VALVE - UNI EN 1717 PNC 922347
- MULTIPURPOSE HOOK PNC 922348
- FLAT BAKING TRAY WITH 2 EDGES-GN1/1 PNC 925006

**Convection Oven
Natural Gas Convection Oven 10GN 1/1**

The company reserves the right to make modifications to the products
without prior notice. All information correct at time of printing.



Convection Oven Natural Gas Convection Oven 10GN 1/1

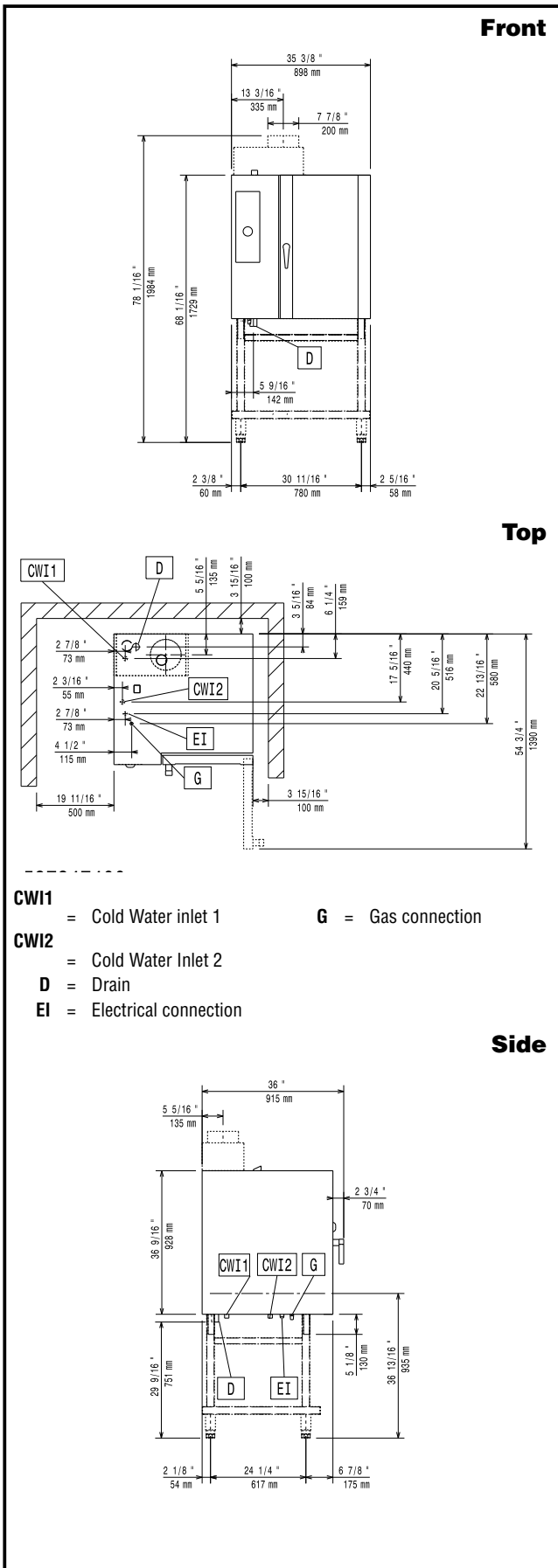

Electric

Supply voltage:
646572 (HOR101GKG) 230 V/1N ph/50/60 Hz

Electrical power max.: 0.3 kW

Circuit breaker required

Gas

ISO 7/1 gas connection diameter: 1/2" MNPT

Natural gas:

Pressure: 7" w.c. (17.4 mbar)

Heating elements: 68180 BTU (20 kW)

Total thermal load: 68180 BTU (20 kW)

Water:

Water inlet "CW" connection: 3/4"

Total hardness: 5-50 ppm

Pressure, bar min/max: 1.5-4.5 bar

Drain "D": 1"1/4"

Electrolux recommends the use of treated water, based on testing of specific water conditions.

Please refer to user manual for detailed water quality information.

Installation:

Clearance: 5 cm rear and right hand sides.

Suggested clearance for service access: 50 cm left hand side.

Capacity:

GN: 10 - 1/1 Gastronorm

Max load capacity: 50 kg

Key Information:

External dimensions, Height: 1058 mm

External dimensions, Width: 898 mm

External dimensions, Depth: 915 mm

Net weight: 147 kg

Shipping weight: 167 kg

Shipping volume: 1.19 m³