

04/2017

Mod: ML80-PU

Production code: LM 80 PEDP



Diamond
catering equipment

Lavatrice LM 80, Essiccatoio ES 80
Washing Machine LM 80, Tumble dryer ES 80
LM 80 Waschmaschine, ES 80 Trockner
Lavadora LM 80, Secadora ES 80
Machine à laver LM 80, Séchoir ES 80
Стиральная машина LM 80, Сушильная машина ES 80



	LM 80 PEDP	LM 80 PEDV	ES 80 PEE	ES 80 PEHP
	POMPA DI SCARICO DRAIN PUMP ABLAUFPUMPE BOMBA DE DRENAJE POMPE DE VIDANGE СТОК НАСОС Art n° 428272	VALVOLA DI SCARICO DRAIN VALVE ABLASSVENTIL VÁLVULA DE DRENAJE VANNE DE VIDANGE дренажный вентиль Art n° 428271	VENTILATO EXHAUST FAN ABLUF EXTRACTOR DE AIRE VENTILATEUR ВЫТЯЖНОЙ ВЕНТИЛЯТОР Art n° 456338	POMPA DI CALORE HEIZUNG PUMP HEIZUNG PUMP BOMBA DE CALOR CHAUFFAGE POMPE Циркуляционный насос Art n° 455616
Capacità (1:7,5 - 1:16) [kg] Capacity (1:7,5 - 1:16) [kg] Füllgewicht (1:7,5 - 1:16) [kg] Capacidad (1:7,5 - 1:16) [kg] Capacité (1:7,5 - 1:16) [kg] Загрузка (1:7,5 - 1:16) [кг]	8	8	8	8
	(cotone, cotton, baumwolle, algodón, coton, хлопок)	(cotone, cotton, baumwolle, algodón, coton, хлопок)	(cotone, cotton, baumwolle, algodón, coton, хлопок)	(cotone, cotton, baumwolle, algodón, coton, хлопок)
Larghezza [mm] Width [mm] Breite [mm] Anchura [mm] Largeur [mm] Ширина [mm]	595	595	595	595
Profondità porta chiusa / porta aperta [mm] Depth door close / door open [mm] geschlossene Tür/geöffnete Tür Tiefe [mm] Profundidad puerta cerrada / puerta abierta [mm] Profondeur porte fermé / porte ouverte [mm] Глубина дверь закрыт / дверь открыт [mm]	700 / 1066	700 / 1066	745 / 1170	745 / 1170
Altezza senza piedini [mm] Height without adjustable feet [mm] Höhe ohne FüÙe [mm] Altura sin pies [mm] Hauteur sans pieds [mm] Высота без ножек [mm]	850	850	850	850
Altezza massima piedini (mm) Rubber feet maximum height (mm) Maximale Höhe Beine (mm) Patas de altura maxima (mm) Pieds de hauteur maximale (mm) Максимум ноги высота (mm)	15	15	15	15
Volume imballo [m ³] Packing volume [m ³] Verpackung Volumen [m ³] Volumen embalaje [m ³] Volume emballage [m ³] Объём упаковки [м ³]	0.456	0.456	0.476	0.476

	LM 80 PEDP POMPA DI SCARICO DRAIN PUMP ABLAUFPUMPE BOMBA DE DRENAJE POMPE DE VIDANGE СТОК НАСОС Art n° 428272	LM 80 PEDV VALVOLA DI SCARICO DRAIN VALVE ABLASSVENTIL VÁLVULA DE DRENAJE VANNE DE VIDANGE дренажный вентиль Art n° 428271	ES 80 PEE VENTILATO EXHAUST FAN ABLUF EXTRACTOR DE AIRE VENTILATEUR ВЫТЯЖНОЙ ВЕНТИЛЯТОР Art n° 456338	ES 80 PEHP POMPA DI CALORE HEATING PUMP HEIZUNG PUMP BOMBA DE CALOR CHAUFFAGE POMPE Циркуляционный насос Art n° 455616
Peso netto [Kg] Net weight [Kg] Nettogewicht [Kg] Peso neto [Kg] Poids net [Kg] Вес нетто [Kg]	92	92	45	62
Umidità residua dopo la centrifuga [%] After spin residual humidity [%] restliche Feuchtigkeit nach Schleuder [%] Humidez residual despues de la centrifuga[%] Humidité résiduelle après essorage [%] Остаточная влажность после отжима [%]	58	58	---	---
Velocità di centrifuga [rpm] Spin speed [rpm] Schleuder Drehzahl [rpm] Velocidad centrifugadora [rpm] Vitesse essorage [rpm] Скорость отжима [об/мин]	1200	1200	---	---
Volume Cestello (lt) Drum Volume (lt) Volume Warenkorb (lt) Cesta Volumen (lt) Volume Panier (lt) Объем корзины (lt)	80	80	145	145
Classe Energetica Energy Class Energie-Effizienzklasse Clasificación Energética Classe énergétique Класс энергопотребления	A++	A++	A++	---
Grado di Protezione IP IP Class of Protection Code IP-Schutzziffern Grado de protección IP Indice de protection IP IP (степень защиты оболочки)	X4	X4	X4	X4
Potenza elettrica di installazione [kW] Installation electrical power [kW] Installationsleistung [kW] Potencia electrica de instalación [kW] Puissance électrique installation [kW] Мощность [кВт]	4.6	4.6	3.30	0.9
Rumorosità [dB] Noise [dB] Geräusch [dB] Intensidad acústica [dB] Bruit [dB] шумность [дБ]	69	69	66	66

	LM 80 PEDP POMPA DI SCARICO DRAIN PUMP ABLAUFPUMPE BOMBA DE DRENAJE POMPE DE VIDANGE СТОК НАСОС Art n° 428272	LM 80 PEDV VALVOLA DI SCARICO DRAIN VALVE ABLASSVENTIL VÁLVULA DE DRENAJE VANNE DE VIDANGE дренажный вентиль Art n° 428271	ES 80 PEE VENTILATO EXHAUST FAN ABLUF EXTRACTOR DE AIRE VENTILATEUR ВЫТЯЖНОЙ ВЕНТИЛЯТОР Art n° 456338	ES 80 PEHP POMPA DI CALORE HEATING PUMP HEIZUNG PUMP BOMBA DE CALOR CHAUFFAGE POMPE Циркуляционный насос Art n° 455616
Connessione elettrica Electrical connection Elektrische Anschluss Conexión electrica Connexion électrique Вид нагрева	1ph 230V 3ph 400V+N 50 Hz	1ph 230V 3ph 400V+N 50 Hz	1ph230V (Shucko) 50 Hz	1ph230V (Shucko) 50 Hz
Fusibile [A] Fuse [A] Schütz [A] Fusible [A] Coupe – circuit [A] Предохранитель [A]	16A (1ph 230V) 10A (3ph 400V+N)	16A (1ph 230V) 10A (3ph 400V+N)	16	10
Lunghezza cavo alimentazione [mm] Supply cable length [mm] Versorgung Kabel Länge [mm] Largura cable alimentación [mm] Longueur câble alimentation [mm] Длина питающего провода [мм]	2100	2100	2100	2100
Conessioni acqua Water connexion Wasser Anschluss Conexiones agua Connexion eau Соединение воды	¾"	¾"	---	---
Pressione di alimentazione acqua [MPa] Water pressure [MPa] Wasser Versorgung Druck [MPa] Presión de alimentación agua [MPa] Pression alimentation eau [MPa] Давление воды [MPa]	0.1 - 1	0.1 - 1	---	---
Lunghezza tubi di carico [mm] – Allacciamento acqua ["] Inlet tube length [mm] – Water Connection ["] Ladung Rohr Länge [mm] – Wasseranschluss ["] Largura conductos de descargas [mm] - Conexión de agua ["] Longueur tuyau [mm] - Connexion Eau ["] Длина труба подвода воды [mm] - Подключение воды ["]	1500 – ¾" (PEX tubing)	1500 – ¾" (PEX tubing)	---	---
Lunghezza tubo di scarico e diametro [mm] Drain tube length and diameter [mm] Ausladung Rohr Länge und Durchmesser [mm] Largura conductos de descargas y el diámetro [mm] Longueur du tuyau vidange et le diamètre [mm] Длина выхлопной трубы и диаметр [мм]	1550 – Ø20 (polypropylene tubing)	---- Ø50	---	---
Lunghezza scarico condensa [mm] Condenses drain length [mm] Kondensablauf Länge [mm] Largura descarga de condensación [mm] Longueur tuyau vidange condenseur [mm] Длина выброса конденсата [мм]	---	---	3000	---

	LM 80 PEDP POMPA DI SCARICO DRAIN PUMP ABLAUFPUMPE BOMBA DE DRENAJE POMPE DE VIDANGE СТОК НАСОС Art n° 428272	LM 80 PEDV VALVOLA DI SCARICO DRAIN VALVE ABLASSVENTIL VÁLVULA DE DRENAJE VANNE DE VIDANGE дренажный вентиль Art n° 428271	ES 80 PEE VENTILATO EXHAUST FAN ABLUFT EXTRACTOR DE AIRE VENTILATEUR ВЫТЯЖНОЙ ВЕНТИЛЯТОР Art n° 456338	ES 80 PEHP POMPA DI CALORE HEATING PUMP HEIZUNG PUMP BOMBA DE CALOR CHAUFFAGE POMPE Циркуляционный насос Art n° 455616
Serbatoio acqua [lt] Water container [lt] Reservoir d'eau [lt] Wasserbecken [lt] Tanque agua [lt] Емкость для воды [lt]	---	---	---	3.5

PLM 8

Rear

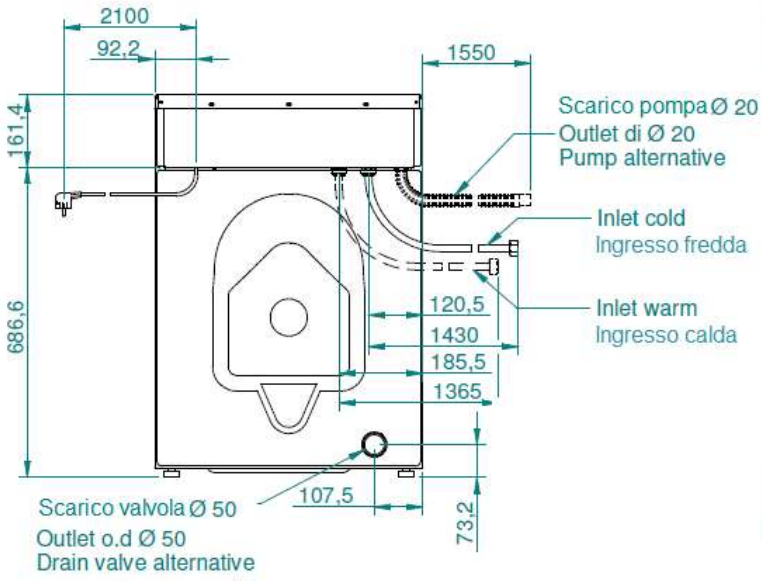

Right

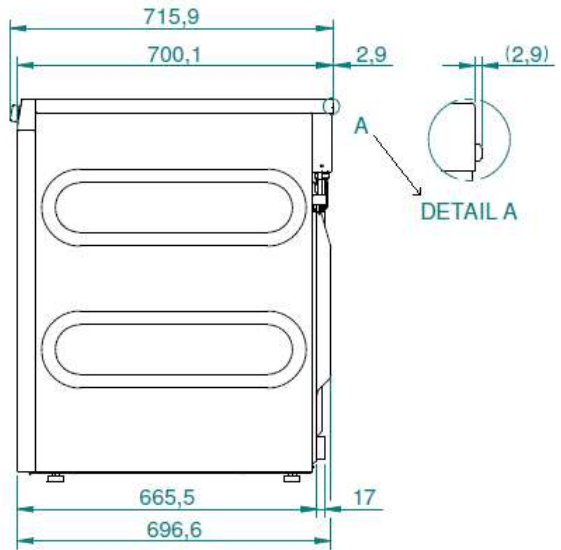

Top

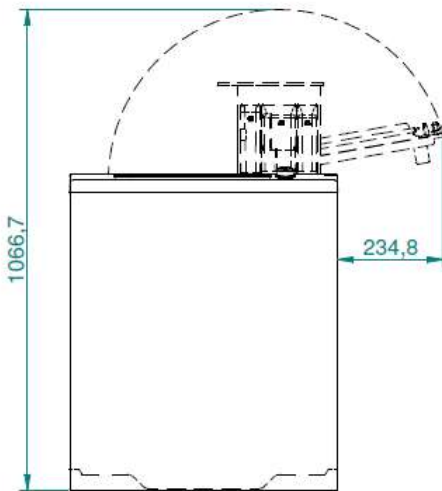

Front

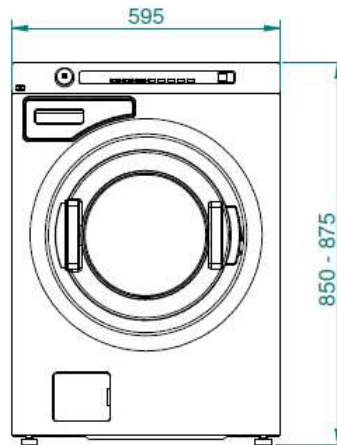

PES 8

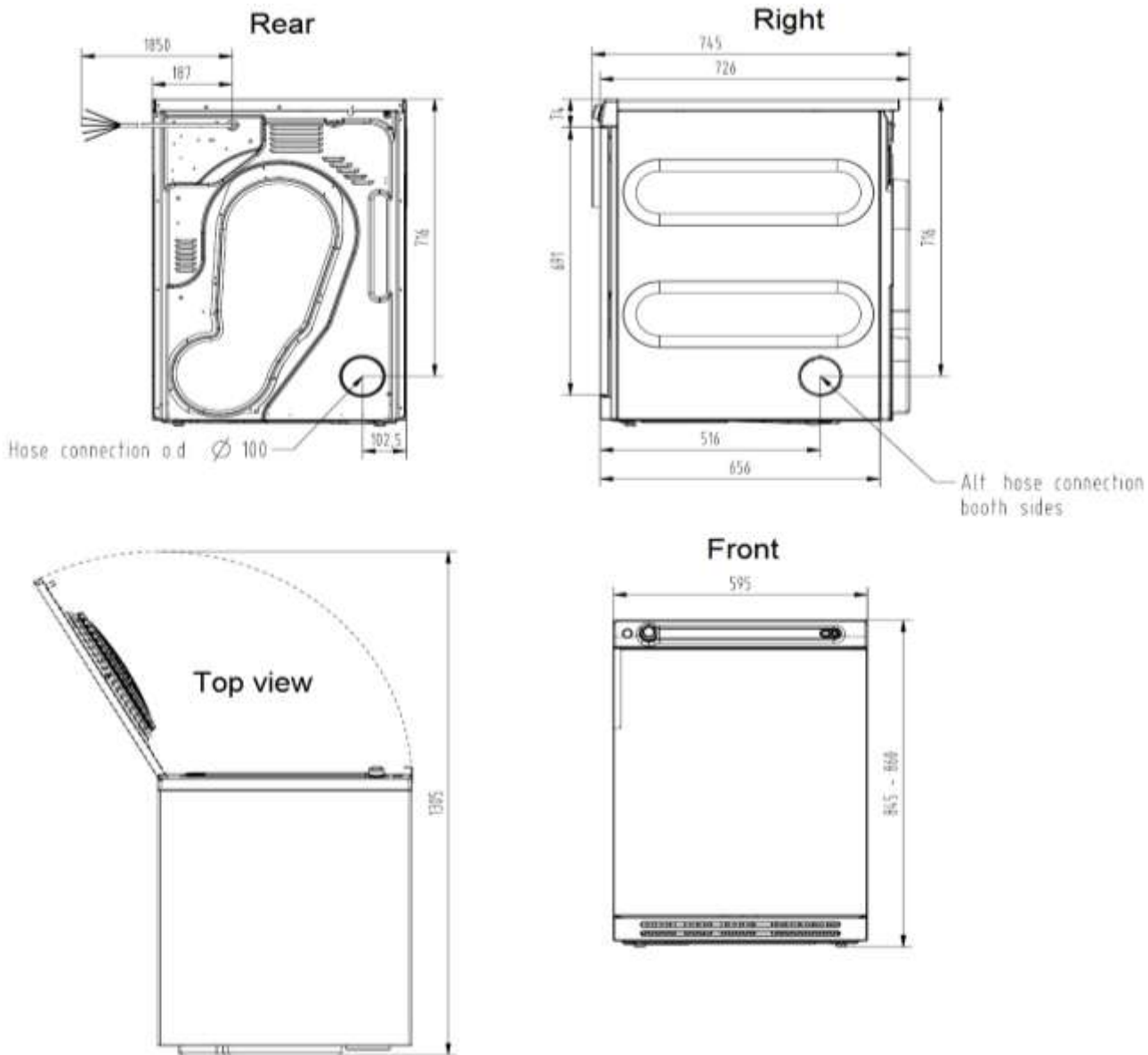

DISPOSIZIONE PIEDINI - RUBBER FEET DISPLACEMENT

VISTA DA SOPRA - TOP VIEW

