



MOD: FD53AL/T2V-L-230/3-

Production code : 11056080

01/2024

ENGLISH

MARKING PLATE	15
SERIAL LABEL.....	15
GENERAL INFORMATION	15
THE IMPORTANCE OF THE MANUAL	15
WARRANTY.....	15
NOISE INFORMATION	15
SAFETY WARNINGS	16
RESIDUAL RISKS	17
TECHNICAL DATA	17
CHARACTERISTICS OF THE MACHINE	17
USE LIMITATION	17
INSTALLATION	18
REQUIREMENTS TO BE USED.....	18
INSTALLATION.....	18
ELECTRIC CONNECTION.....	19
FUNCTIONING	19
SAFETY DEVICES.....	19
CONTROL DEVICES.....	20
USE OF MACHINE	21
ADVICE TO CORRECTLY USE THE MIXER	22
FUNCTIONING ANOMALIES.....	23
MAINTENANCE	24
CLEANING	25
TENSIONING OF THE UPPER CHAIN	25
TENSIONING OF THE UPPER CHAIN.....	25
DEMOLITION AND DISPOSAL	25

MARKING PLATE

SERIAL LABEL

The plate bears in readable and indelible way the following data:

- Name of the manufacturer;
- CE marking;
- Model (MOD);
- Electric power (kW/A);
- "Made in Italy"
- Serial number ;
- Electric voltage and frequency (Volt/Hz);
- Year of construction ;
- Weight of the spiral mixer;

GENERAL INFORMATION

THE IMPORTANCE OF THE MANUAL

Before using the concerned spiral mixer, it is compulsory to read and understand this manual in all its parts.

This manual must always be available for the "authorized operators" and has to be placed and preserved close to the oven.

The manufacturer declines all liability for eventual damages to persons, animals, and things caused by the inobservance of the regulations described in this manual.

This manual is an integral part of the spiral mixer and must be preserved until its final dismantling.

The "authorized operators" must perform on the spiral mixer exclusively interventions for which they are specifically competent.

WARRANTY

The duration of the warranty is one year and starts from the date of the fiscal receipt issued at the time of purchase.

Within this period, the details will be replaced or repaired free of charge and only at our factory that, for well-established and unequivocal causes, will result in manufacturing defects, with the exception of electrical components and those subject to wear.

Shipping costs and labor costs are excluded from the warranty.

The warranty is void in the cases in which it is ascertained that the damage has been caused by: transport, incorrect or insufficient maintenance, lack of operators, tampering, repairs performed by unauthorized personnel, failure to comply with the provisions of the manual.

Any recourse against the manufacturer for direct or indirect damages resulting from the time when the machine will remain inoperative is excluded:

failure, waiting for repairs, or in any case referable to the non-physical presence of the equipment.



THE TAMPERING AND/OR REPLACEMENT OF PARTS WITH NON ORIGINAL SPARE PARTS CAUSE THE DECAY OF THE WARRANTY And RELEASE THE MANUFACTURER FROM ANY LIABILITY.

NOISE INFORMATION

The A-weighted sound pressure level measured on an identical sample machine was consistently lower than 80 dB (A).

If the working environment has a noise level higher than 80 dB (A), the employer is obliged to inform and train the operator on the risks arising from exposure to noise and take appropriate measures in agreement with the competent doctor

SAFETY WARNINGS

Although the machine complies with the safety requirements of the reference standards, electrical, mechanical, hygienic, it can be dangerous if:

- Used for purposes and conditions other than those provided by the manufacturer.
- Protections are tampered with.
- The prescriptions for: Installation - Commissioning - Use - Maintenance are not observed.

ATTENTION

In order to prevent dangerous conditions and / or possible injuries caused by: electric current, mechanical parts, fire or of a hygienic nature, the following safety warnings must be observed.

A - KEEP YOUR OWN WORKPLACE IN ORDER.

The disorder involves a danger of accidents.

B - EVALUATING THE ENVIRONMENTAL CONDITIONS.

Do not use the machine in a humid, wet or insufficiently lit environment, near flammable liquids or gases.

C - KEEP CHILDREN AND NON-EMPLOYEES AWAY.

Do not allow them to approach the machine or the workplace.

D - USE THE MACHINE UNDER THE PLATE POWER AND FOR THE ONLY PERMITTED USE.

Without overload, it will work better and safer.

E - DRESS IN AN ADEQUATE WAY.

Do not wear loose clothes or accessories that can get caught in moving parts. Use non-slip shoes. For reasons of hygiene as well as safety, for long hair use the appropriate mesh and gloves for hands.

F - PROTECT THE POWER SUPPLY CABLE.

Do not pull the cord to unplug the plug; do not expose the cable to high temperatures, in contact with sharp edges, water or solvents.

G - AVOID INSURING POSITIONS. Search for the most suitable position that always ensures balance.

H - ALWAYS PAY THE MAXIMUM ATTENTION.

Observe your work. Do not use the machine when you are distracted.

I - EXTENDED OPEN AIR CABLES. They must not be used.

L - MACHINE IN FUNCTION UNATTENDED. It must not be left

M - DISCONNECT THE PLUG FROM THE SOCKET.

At the end of each use, before cleaning, maintenance or moving the machine.

N - CHECK THAT THE MACHINE IS NOT DAMAGED.

Before using the machine, carefully check the efficiency of the safety devices. Check that the moving parts are not blocked, that there are no damaged components, that all parts have been correctly assembled and that all conditions that could affect the correct operation of the machine are optimal.

O - MAKE THE MACHINE BY QUALIFIED PERSONNEL REPAIR.

Repairs must only be performed by qualified persons using original spare parts. Failure to comply with these provisions may constitute an element of danger for the user.

P - THE LABELS ARE ANTI-ACCIDENTIAL DEVICES, therefore they must always be perfectly legible. If they are damaged and illegible, it is mandatory to replace them

RESIDUAL RISKS

Loading, unloading and movement of the machine	- Machine falls - Packaging falls	- Handle the machine carefully, packaged or not.
Wrong machine installation	- Electrical discharges - Lightning strike	- The mains voltage and frequency as outlined on the machine plate. - The power socie must be connected to the earthing. - The electricity supply line of the machine, upstream of the socket must be equipped with protection using a differential switch, coordinated with the main earthing system.
Closure panels, chambre in which voltage is present	- Electrocutation	- Do not open the panels without disconnecting the plug in advance.
Work without guards	- Electrocutation - Catching - Crushing - Abrasion	- Do not remove the guards during machine use.
Cleaning the parts in contact with the mixture	- Electrocutation - Electrical discharges	- The machine must always be cleaned when it is off, without mains power (cut mains voltage, i.e. disconnect the plug).

TECHNICAL DATA

CHARACTERISTICS OF THE MACHINE

The electric spiral mixer, produced in versions "5", "10", "15", "20", "30", "40", "50", "60" was designed to blend both soft and hard mixtures (mix and/or knead), made of flour, salt, yeast, fats and liquids (water, oil, ...) exclusively for foodstuff use.

Every mixer is composed of:

- a steel structure protected by a heat resistant varnish;
- the bowl, the spiral, the central dough-breaker and the protection grate are all in stainless steel ; the bowl and the spiral they both rotate clockwise



- chain drive with oil bath gear motor;
- the moving parts are on ball bearing;
- 4 castors , 2 of these with brake, in nylon;
- operation with single-phase or three-phase motor, one speed; on request: three-phase motor with 2 speeds;
- Electric circuit fed by a cable to the network to which are connected at low tension (24V) the control devices to start, to stop, and of the safety devices. Among these internal blocking of the moving parts activated by the movement of the mobile protection of the pan

The machine, designed in compliance with European Directives, is built to safeguard the user from risks relating to its use. For this reason, the machine is equipped with specific guards that must not be tampered with for any reason, in order to avoid risks due to contact with moving parts.

USE LIMITATION

	5	10	15	20	30	40	50	60
PRODUCTION CAPACITY kg/h The data refer to a normal mix of ten/twelve minutes	29	35	48	56	88	112	128	144

INSTALLATION

REQUIREMENTS TO BE USED

The environmental conditions of the place where the machine is installed must have the following characteristics:

- be dry
- heat sources that are adequately distant
- adequate ventilation and lighting complying with the hygiene and safety standards required by current laws.
- The support surface must be horizontal, must not be placed in the immediate vicinity of the machine obstacles of any kind that may affect the normal ventilation of the same.

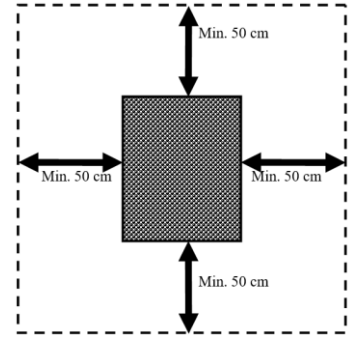

IMPORTANT

In compliance with current laws, the electrical network must be equipped with an automatic differential switch with characteristics appropriate to those of the machine in which the opening distance of the contacts is at least 3 mm; indispensable, moreover, an efficient grounding system.

Check that the supply voltage and the frequency of the system are compatible with the values shown both in the **technical features** and on the plate on the back of the machine.

INSTALLATION

IMPORTANT

All installation and maintenance operations must be carried out by qualified personnel authorized by the manufacturer, who declines all responsibility deriving from incorrect installation or tampering.

The machine is supplied on pallets in a closed package with cardboard. To lift the machine, you need a forklift or a transpallet. If the machine is lifted with the aid of ropes or belts, pass them under the pallet. To remove the machine from the packaging, you can use straps positioned under the machine and hooked to a forklift truck (FIG.3).

NOTE

All the details relating to the packaging must be disposed of according to the regulations in force.

After removing the machine from the packaging proceed as follows:

- Place the machine in the intended location.
- Remove the protective film, where present, avoiding the use of tools that can damage the surfaces.
- If the machine has the wheels mounted, make sure that they are locked with the brake, pushing the lever "A" downwards until it stops (FIG.4).
- If the machine is unstable put under the feet or wheels pieces of hard rubber.

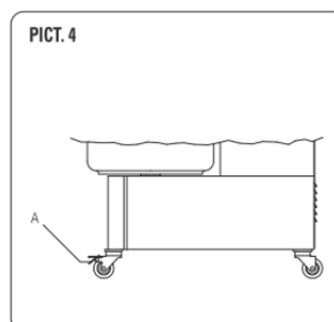
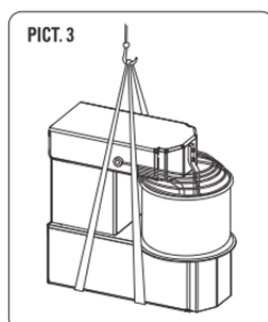

In the normal working conditions and to have the best exploration of the potentiality of the machine, the operator needs the area represented in pict. below

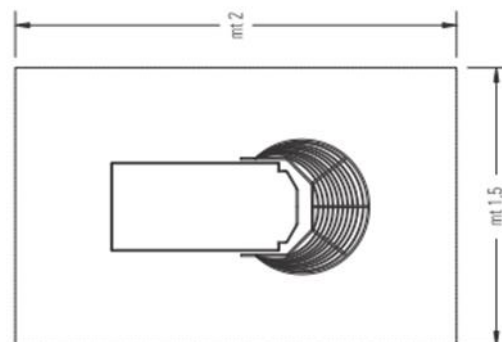

ELECTRIC CONNECTION

The machine is connected to the mains power supply by means of the supplied power cord, which must be fitted by a specialized and qualified staff, with its 16 / 32 A for 3-pole cable (F, N, T) for single-phase and 4 / 5-pole cable (3F, T / 3F, N, T) for three-phase versions.

The mains socket must be easily accessible, it must not require any movement.

The distance between the machine and the socket must be such that it does not cause the power cord to tension, also the cable must never be under the supports of the machine.

IMPORTANT

It is mandatory that the system is equipped with earth connection and differential switch in compliance with the laws in force.

FUNCTIONING

SAFETY DEVICES

The machine is equipped with adequate safety devices made of fixed guards, and an adequate distance between the bowl and the machine casing, with the scope of avoiding contact of parts of the human body (upper limbs) with the rotating bowl during the work phase, to eliminate the risks of dragging or crushing. The machine is equipped with a lid sensor on the open bowl, with the scope of avoiding contact of parts of the human body (upper limbs) with the moving parts during the work phase, to eliminate risks of dragging, crushing and abrasion.



DO NOT REMOVE THE GUARDS DURING USE OF THE MACHINE. THE MANUFACTURER CANNOT BE HELD IN ANY WAY LIABLE FOR NON COMPLIANCE WITH THE AFOREMENTIONED INSTRUCTIONS.

Whit reference to figure 8, the guards are:

- I – moving protection grate
- L – Device proving that the top and the protection cover are up or down (only on tilting head mixers)
- M, M1 – Check pin of the top (down position, only on tilting head mixers)
- N – Device proving that the bowl is in or out (only on tilting head mixers)
- O – Blocking disk of the bowl (only on tilting head mixers)

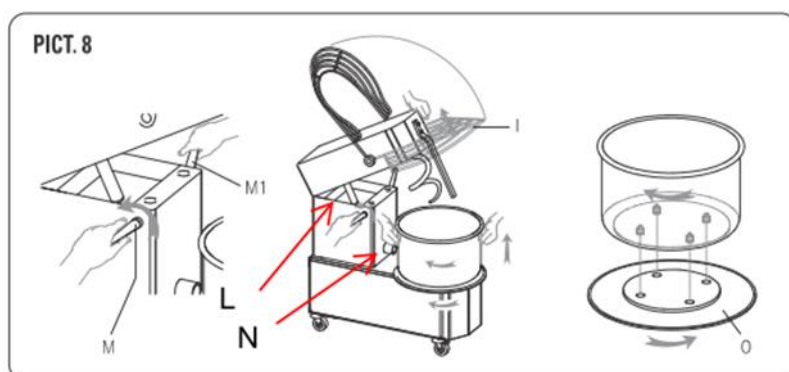

Before operating the machine, the protection I (PICT. 9) must be completely lowered. For tilting head mixers it must be checked that the bowl is correctly inserted and blocked by the disk 0 and that the top is down and blocked by the check pin M (this must be completely inserted).



CONTROL DEVICES

Depending on the model, the machine is equipped with the following control devices:

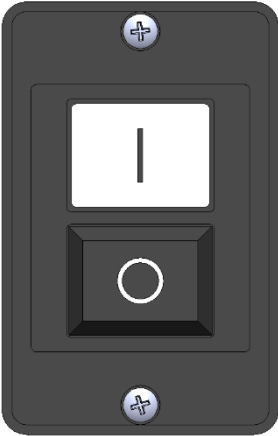
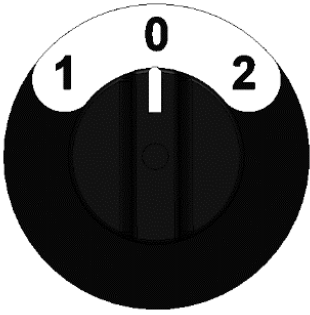
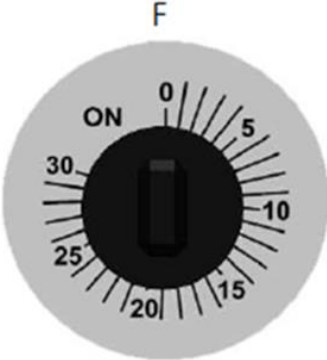
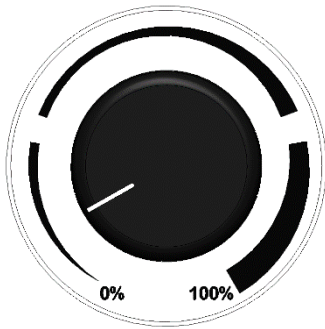
			
FIG. 5	FIG. 6	FIG. 7	FIG. 8
COMMAND	ACTION		POSITION
<i>ON - OFF SWITCH (FIG. 5)</i>			
A) ON button	Activates (1) movement of the rotating parts.		Side of machine
B) OFF button	Stops (0) movement of the rotating parts.		Side of machine
<i>TIMER (FIG. 7)</i>			
F) Timer	allows the machine to start up and allows setting the working time		Side of machine
<i>SPEED SELECTOR (FIG. 6)</i>			
Pos. 0	Stops movement of the rotating parts.		Side of machine
Pos. 1	Activates movement of the rotating parts at first speed.		Side of machine
Pos. 2	Activates movement of the rotating parts at second speed.		Side of machine
<i>INVERTER (FIG. 8)</i>			
Speed control	Turning the knob, increases / decreases the speed of the tank and the spiral		Side of machine

Functional check first start:

After inserting the power cord plug into the mains socket, the machine is ready for functional verification.

- **Before starting the machine, make sure that all the protections are correctly installed.**
- **When first starting, check that the spiral and the bowl rotate both clockwise. If this were not to reverse the arrangement of the phases.**

USE OF MACHINE

Below, a series of sequences are described, for the correct use of the machine:



BEFORE STARTING WORK MAKE SURE THAT THE MACHINE IS PERFECTLY CLEAN IN PARTICULAR, THE SURFACES OF BOWL, THE SPIRAL AND OF THE CENTRAL COLUMN THAT HAVE CONTACT WITH THE FOOD PRODUCTS. IF NECESSARY CLEAN THEM FOLLOWING INDICATIONS.

Lift the protection "I" and pour the ingredients necessary for the mixture into the bowl, then lower the bowl protection and activate the rotation of the bowl and the spiral as described below.

To visually check the consistency of the dough, or to add further ingredients, it is possible to do it through the protection grid, without lifting it and thus interrupting the operation of the machine.

Lifting the protection, the machine stops: at closing, it is necessary to press button 1 again to restart the rotation of the bowl.

Start-up situation with "machine off":

- Rotate the protection differential switch to the ON position, coordinated with the main earthing system, placed upstream of the machine in the user's system;
- Turn the timer knob clockwise and select the desired working minutes for the timed cycle.
- Press Button 1 that activates rotation of the bowl and the spiral



CHECK AGAIN THAT IT IS THE BLOW AND THE SPIRAL, WHEEL BOTH CLOCKWISE.

Start-up situation with "machine powered":

To re-start work, following suspension of the work, press button 1 having restored the safety present.

Start-up situation with "machine in emergency mode" (example thermal protection tripped):

- switch off the machine, with the sequence of commands indicated in point "MACHINE SWITCH OFF";
- leave the electric motor to cool for approx. half an hour;
- start the machine, with the sequence indicated in point "START-UP SITUATION WITH MACHINE OFF".

Machine switch off

For total machine switch off, from the work terminated or shut-off condition, you need to:

- Press Button 0 that terminates rotation of the bowl and the spiral.
- Rotate the knob on the timer in position 0.
- Rotate the protection differential switch to the OFF position, coordinated with the main earthing system, placed upstream of the machine in the user's system, which disconnects the machine from the electrical power supply.

Note: In a machine fed electrically by three-phase, if the rotation of the bowl is opposite the way shown by the arrow it is necessary to follow these indications for the functioning and every time you change the electric plug:

- Stop the machine;
- Take the plug out.
- Reverse on the plug the position of two phases (ex. L1 with L2) .
- Restart the machine and verify if the bowl is rotating the right way;
- Start the machine without using it, let it on for about one minute and verify that it is functioning perfectly.

USE OF THE MACHINE WITH RISING TOP AND REMOVABLE BOWL

In order to raise the top and to take off the bowl proceed as follows:

- stop the machine, unplug the machine;
- raise the protection I completely (PICT. 10);
- pull the pin M as far as the top is blocked;
- raise the top by means of the little piston underneath;
- rotate clockwise the disk O as far as the bowl is unlocked;
- raise the bowl and take it off;
- take off the dough.

In order to repositioning of the bowl and top, proceed as follows:

Once the cleaning is done:

- put the bowl back on, and make sure that the four pins underneath are correctly fixed in the four holes "K" of the machine;
- then block the bowl rotating in the opposite direction to the disk "O" (fig.11);
- Put the top down pushing it downwards (PICT. 9) as far as it is blocked by the pin M.

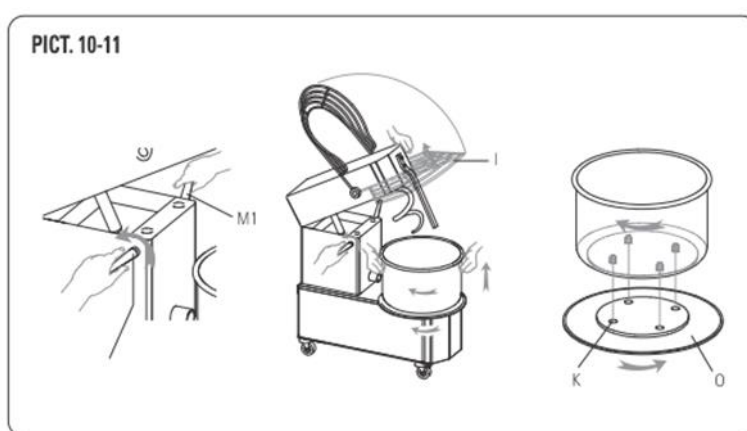

WHEN THE MACHINE IS NOT ACTIVE, SELECT (SWITCH OFF) THE MAIN SYSTEM OF THE ELECTRICAL ENERGY MAINS AND DISCONNECT THE CURRENT SOCKET.

ADVICE TO CORRECTLY USE THE MIXER

The best mixing result can be achieved by proceeding as follows:

- 1- Pour approximately 3/4 of the total water into the tank;
- 2- Set the timer to the desired work time and turn on the mixer. Approximately 15/20 minutes in total;
- 3- Slowly add the flour and yeast;
- 4- Adjust the consistency of the mixture by slowly adding the remaining water (1/4) while continuing to mix;
- 5- Let the machine work for a few minutes and then add the salt;
- 6- If required, add the olive oil slowly while continuing to mix;
- 7- Let the mixer work until the set time has elapsed. Do not exceed 20 minutes.

ATTENTION:

The mixer will not mix properly if flour is poured first followed by water. The mixture will stick to the walls or the flour will remain on the bottom.

If 20 minutes are exceeded, the mixture will overheat and its properties will be altered.

To obtain a correct mixture, all the temperatures involved must be monitored; room, flour, water and temperature released by the mixer during operation (approximately 10°C).

An optimal temperature of the mixture at the end of the cycle ranges from +22°C to +26°C.

STARTING MACHINE

1. Activate all the safety devices;
2. Pressing the button "I" to activate the machine
3. Set the working time of the machine from 1 to 30 min. by turning the timer knob to the desired position
4. Once the set time is over, the timer stops the machine.
5. Press the "0" button to turn off the machine.

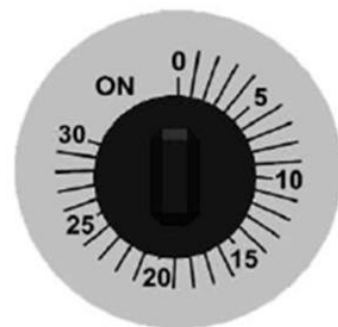
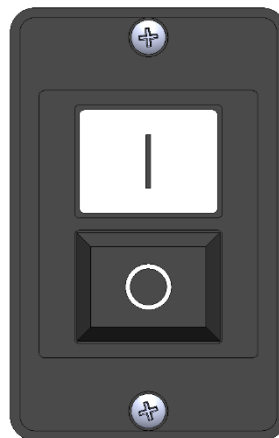

USE OF THE 2 SPEED MACHINE

The machines with three-phase motor can be produced with the second speed. To start these machines, proceed as follows:

1. Start the mixer as previously described in the points 1, 2, 3;
2. Select the desired speed by turning the selector knob to 1 or 2;
3. Once the set time is over, the timer stops the machine.
4. Press the "0" button to turn off the machine.

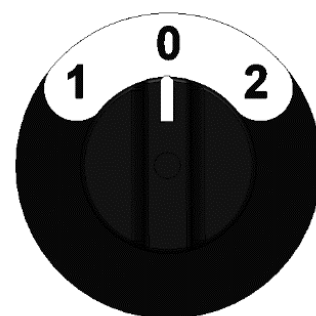

USE OF THE INVERTER MACHINE



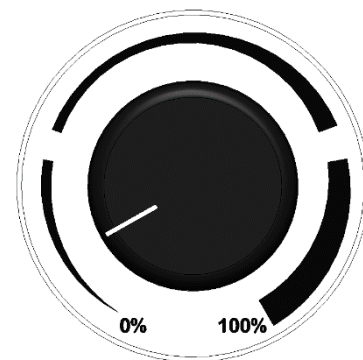

1. Start the mixer as previously described in the points 1, 2, 3;
2. Select the percentage speed by turning the knob of the inverter from 0% = 1st speed to 100% = 2nd speed; Turning the knob from "0%" to "100%" speed increases from minimum to maximum. In the opposite direction, the speed decreases;
3. Once the set time is over, the timer stops the machine.
4. Press the "0" button to turn off the machine.



FUNCTIONING ANOMALIES

PROBLEM	CAUSES	SOLUTIONS
The machine does not start	Lack of electric current	Check the general switch, the plug and the power cord
	The stop button is locked	Press the green button
	The protection grid and / or the lid are raised, or the bowl is not well positioned.	Properly lower both the protection grid and the cover and reposition the bowl
	The timer is in position 0	Set the timer from 1 to 30 minutes or in manual mode
The spiral is not constant in the rotation	The chain is loose	Tighten the chain
The machine stops while it is operating	the fuse does not work	Replace the fuse with another, with the same characteristics

Only for IBV:

LED					CAUSE	SOLUTION
GREEN	Not programmed board or damaged					Replace the board
GREEN			Normal operation			
RED	Normal operation					
RED		Power supply error			The voltage value of the device has too low or device damaged	Check the supply voltage or replace the device
RED				Safety input error	One or more securities are not activated	Check the correct positioning of the safety devices
YELLOW	Engine STOPPED					
YELLOW		Engine running at constant speed				
YELLOW			Engine in speed change phase			

MAINTENANCE

ATTENTION: Before carrying out any maintenance, including cleaning, take the following precautions:

- make sure that the appliance is disconnected from the electrical mains (unplug from the electrical outlet), making sure that the power supply can not be reactivated accidentally;
- Make sure the appliance is completely cooled;
- Use personal protection devices required by current regulations;
- Always operate with appropriate equipment;
- Once the maintenance / repair / cleaning operation has been completed, before putting the appliance back into service, re-install all the protections and safety devices;

CLEANING

ATTENTION: Never use abrasive or corrosive non-food chemical products. Absolutely avoid using water jets, various tools, rough or abrasive media, such as steel scourers, sponges, etc., which can damage surfaces and, in particular, compromise hygiene in terms of hygiene.

Cleaning must be carried out at the end of each use **in observance of the hygiene rules and to protect the machine's functionality**, proceeding as follows:

- Using a wooden or plastic palate first clean the residue of dough;
- with a soft sponge and warm water accurately clean the pan, the spiral, the dough breaker and the mobile protection ;
- dry with kitchen paper, then pass over the parts just mentioned then all the machine with a smooth and cleaned cloth with a specific cleaning products for foods machines.

Note: in the case of a machine with rising top and extractable blow, it is advisable to remove the blow to facilitate cleaning operations;

To maintain the efficiency and security of the machine it is necessary to proceed with periodical maintenance, every 6 months, of the following indications:

TENSIONING OF THE UPPER CHAIN

The chain tension is ensured by the chain tensioner.

If the machine is not equipped with it, if the chain is loose at the control or if the rotation of the spiral is not constant. Unscrew the panel P, (PICT. 14) loosen the screws Q, pull the support of the spiral R as far as the tension of the chain is optimized, lock the support R with the screws Q, put the panel P on once more and fix it.

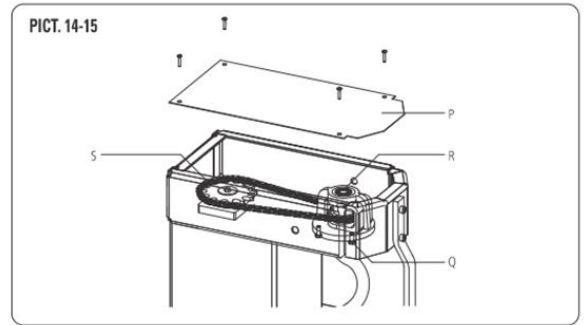

TENSIONING OF THE UPPER CHAIN

To lubricate the chains, proceed as follows:

- unscrewing the fixing screws, take away the upper "P" and the back "V" panels;
- put on the chains S-T (PICT. 15-16) a reasonable amount of proper grease, sufficient to lubricate all the links of the chain;
- mount the 2 panels and secure again with screws.

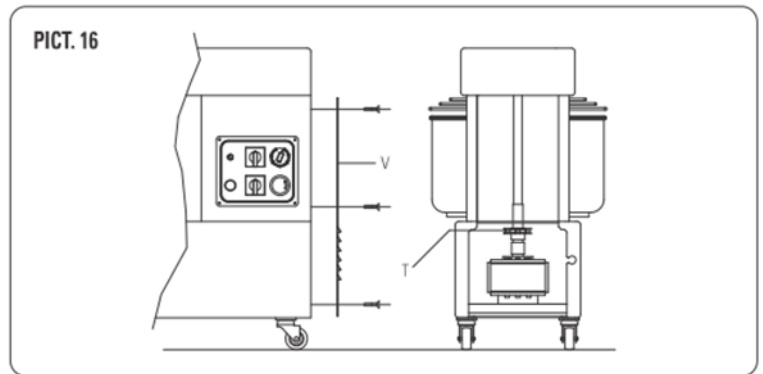

For any maintenance not covered in Ordinary Maintenance, and in the event of malfunctions, only contact the manufacturer.

DEMOLITION AND DISPOSAL



ATTENTION: Demolition and disposal of the machine, are the sole responsibility and responsibility of the owner, who must act in compliance with the laws in force in their country regarding safety, respect and protection of the environment.

When dismantling the machine, compulsorily observe the provisions of the regulations in force. Differentiate the parts making up the oven according to different types of construction materials (plastic, copper, iron, etc.).