



MOD : G60/GPL3T-N

Production code : F60/30GRLG/T

Jet engine compressor drawings

Creative
MARKET

03/2024

Modello/Type: **60/30 GRL**

cod./num. 2531320.00

data/date: 09/05/2013

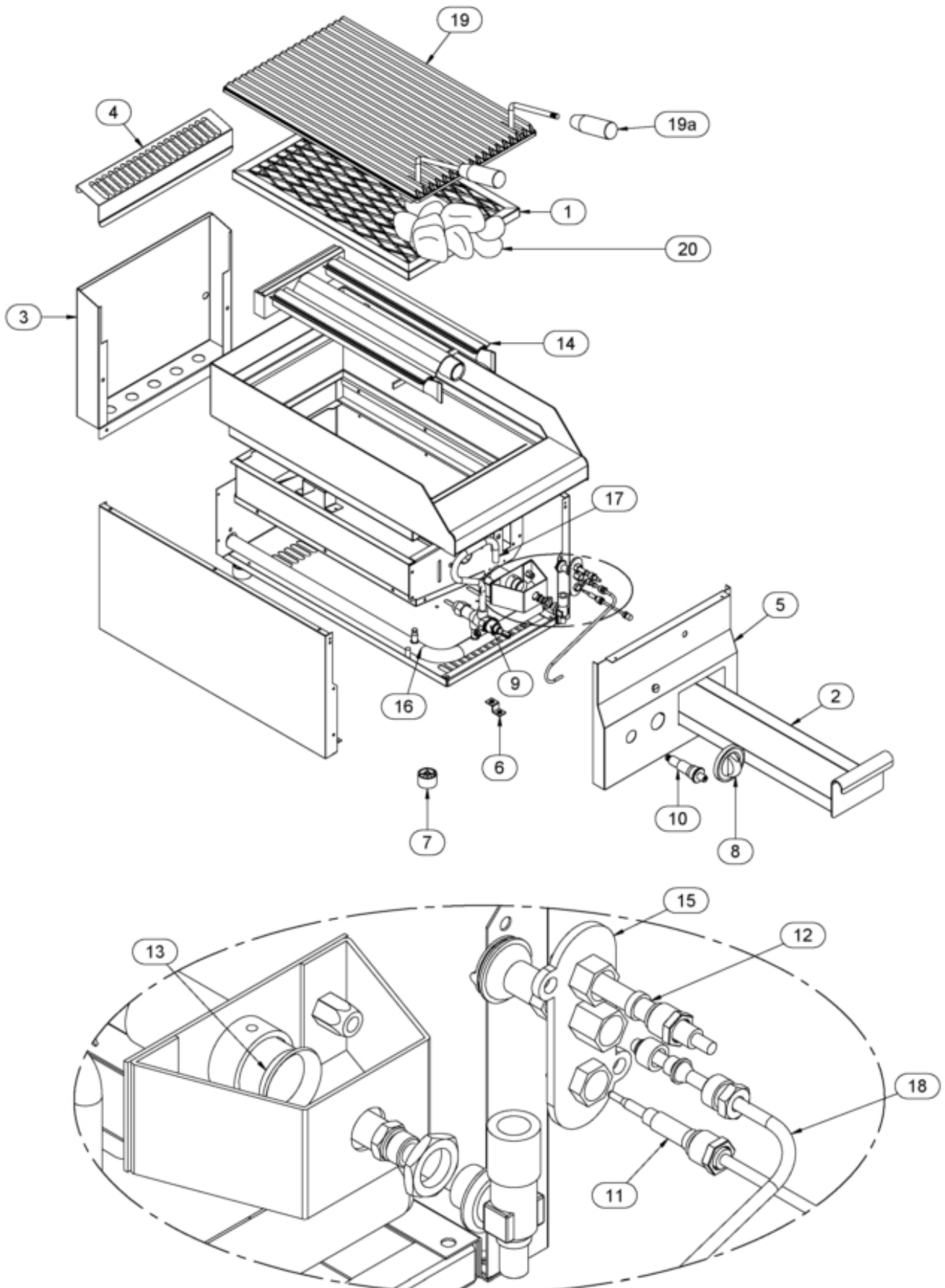

Pos.	Réf.	Description	De	À
0001	6111075.00	ASS. BRACIERE GRL S.600		
0002	6111109.00	ASS.CASSETTO GRL S.6		
0003	621.751.00	SCHIENALE DA 30 S."6"		
0004	611.730.00	ASS.ALZATINA 60/30 FTG		
0005	256.015.00	KIT CRUSCOTTO 60/30 GRL + INDICI		
0006	256.002.00	KIT STAFFA FISS.CRUSCOTTO + VITI		
0007	651.001.13	FOOT DIAM.30 X 20H NEW		
0008	612.079.00	ENS.MANETTE GRISE D62 GAZ PIL.		
0009	671.001.00	ROBINET GAZ DE SECURITE SC PEL 21S		
0010	672.006.00	ALLUMEUR PIEZO		
0011	672.025.00	THERMOCOUPLE L.500		
0012	256.017.00	IGNITION ELECTRODE		
0013	672.133.00	JOURNAL BOX AIR REGULATOR D20X1 GRL		
0014	672.146.00	ASS.BRUCIATORE GRIGLIA GRL S.600		
0015	256.018.00	KIT PILOTA 2VIE 0160 +RAC.+UG.+CAN.		
0016	675.295.00	ASS.RAMPA 60/30 FTG/GRL		
0017	256.019.00	KIT CONDUT.GAS BRUCIATORE GRL S.6		
0018	256.020.00	KIT CONDUT.GAS PILOTA GRL S.6		
0019	256.021.00	KIT GRIGLIA GHISA+IMPUGNAT.GRL S.6		
0020	0855.00001.0	SACCO ROCCIA PIETRA LAVICA		
019a	651.012.00	CYLINDRICAL KNOB MC/28X85 M8		