



MOD : E65/PLCD10T-230V/3-N

Production code : F65/100FTE/CL/T230V/3)

04/2024

Mod.	kW	Volt	Ampere	Hz	Cable	NOTE
_65/100 FT...E...	12	380-415V 3N	20,5	50-60	5G2,5mm ²	

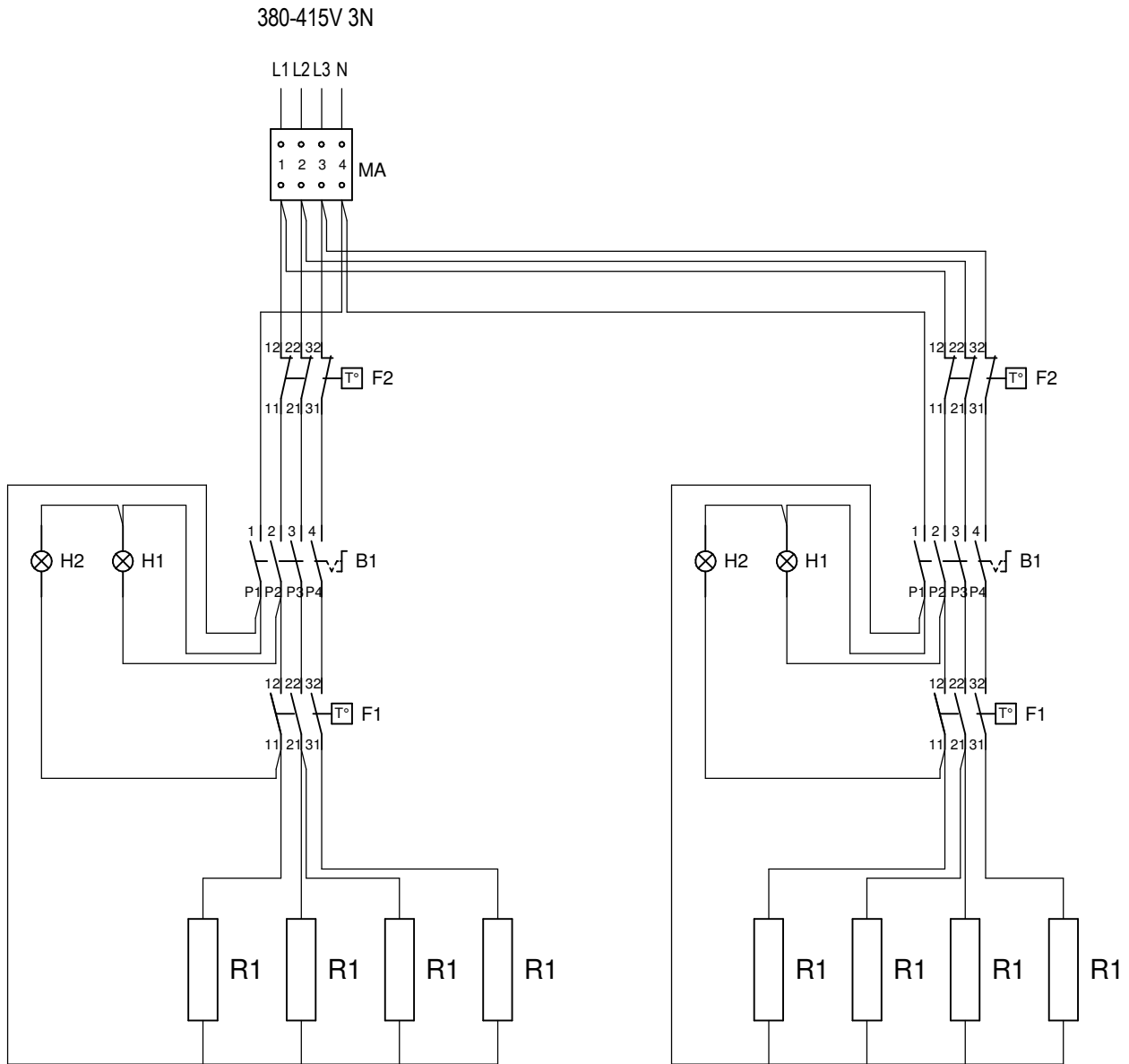

B1	INTERRUTTORE _ INTERRUPTEUR SWITCH _ SCHALTER _ INTERRUPTOR	(EGO 49.41015.300)	COD: 661.000.00
F1	TERMOSTATO _ THERMOSTAT TERMÓSTATO	(EGO 55.34062.803)	COD: 661.007.00
F2	TERMOSTATO SICUREZZA _ THERMOSTAT DE SECURITE SAFETY THERMOSTAT _ TEMPERATURBEGRENZER _ TERMÓSTATO DE SEGURIDAD	(EGO 55.32562.802)	COD: 661.045.00
H1	LAMPADA SPIA VERDE _ LAMPE TEMOIN VERTE GREEN INDICATOR LIGHT _ GRUENE KONTROLLAMPE _ INDICADOR LUMINOSO VERDE		COD: 663.043.00
H2	LAMPADA SPIA ARANCIO _ LAMPE TEMOIN ORANGE ORANGE INDICATOR LIGHT _ ORANGE KONTROLLAMPE _ INDICADOR LUMINOSO NARANJA		COD: 663.044.00
MA	MORSETTIERA ARRIVO LINEA _ BORNES ARRIVE LIGNE POWER INLET TERMINAL BOARD _ ANSCHLUSSBRETT _ BLOQUE TERMINAL LÍNEA	(PA44 16A 450V)	COD: 663.018.00
R1	RESISTENZA _ RESISTANCE HEATING ELEMENT _ HEIZKOERPER _ RESISTENCIA	(1,5kW 230V)	COD: 665.002.00



Prima di intervenire sull' apparecchiatura, scollegare l' alimentazione elettrica - Unplug the power supply before operating on the appliance
 Bevor am gerät arbeiten ausschalten srè die elektrische speisung
 Avant d'intervenir sur l'appareil, déconnectez l'alimentation électrique - Desconnectar el alimentaciòn antes cualquier intervenciòn sobre el aparato

MODELLO:

FRYTOP - GRILLADE - GRILLPLATTEN - GRILLPLAAT

nome:

Lot F.

data:

17/03/2017

modif.:

CODICE:

2511066.00

FOGLIO: 1/1