



MOD : E9/6PQA12-N

Production code : DIPQ912A

09/2023

CODICE DEL DOCUMENTO - DOCUMENT CODE - CODE DU DOCUMENT - CÓDIGO DEL DOCUMENTO - DOKUMENTNUMMER - CÓDIGO DO DOCUMENTO - KOD DOKUMENTU - DOCUMENTCODE - код документа - DOKUMENTKODE - DOKUMENTKOD - DOKUMENTUM KÓDJA:	N° 177376
EDIZIONE - EDITION - ÉDITION - EDICIÓN - AUSGABE - EDIÇÃO - WYDANIE - EDITIE - UTGAVE - UTGÅVA - KIADÁS:	Rev. 11 - 01/2019
TIPO DI DOCUMENTO - TYPE OF DOCUMENT - TYPE DE DOCUMENT - TIPO DE DOCUMENTO - DOKUMENTTYP - TIPO DE DOCUMENTO - TYP DOKUMENTU - DOCUMENTTYPE - тип документа - TYPE DOKUMENT - TYP AV DOKUMENT - DOKUMENTUM TÍPUSA:	M.U.
MODELLO - MODEL - MODÈLE - MODELO - MODELL - модель - MODELL - MODELL:	ELECTRIC
ANNO DI COSTRUZIONE - YEAR OF CONSTRUCTION - ANNÉE DE FABRICATION - AÑO DE FABRICACIÓN - HERSTELLUNGSJAHR - ANO DE FABRICO - ROK PRODUKCJI - BOUWJAAR - ГОД ИЗГОТОВЛЕНИЯ - BYGGEÅR - DE FABRICO - BYGGEÅR - TILLVERKNINGSÅR - GYÁRTÁS ÉVE:	2019
CONFORMITÀ - CONFORMITY - CONFORMITÉ - DECLARACIÓN DE CONFORMIDAD - KONFORMITÄT - CONFORMIDADE - ZGODNOŚĆ - CONFORMITEIT - НОРМАТИВНОЕ СООТВЕТСТВИЕ - SAMSVARSKLÆRING - ÖVERENSSTÄMMELSE - MEGFELELŐSÉG:	CE

Targa di identificazione - Identification plate - Plaque d'identification - Placa de identificación - Typenschild - Placa de identificação - Tabliczka identyfikacyjna - Identificatielabel - Паспортная табличка - ID-skilt - Identifierings skylt - Azonosító tábla.

- A - Indirizzo Costruttore - Manufacturer's Address - Adresse du Fabricant - Dirección del fabricante - Anschrift des Herstellers - Endereço do fabricante - Adres Producenta - Adres Fabrikant - Адрес изготовителя - Adresse produsent - Tillverkarens adress - Gyártó címe.
 B - Apparechiatura Elettrica - Electrical Appliance - Appareil Electrique - Sistema eléctrico - Elektrogerät - Aparelhagem elétrica - Urządzenie Elektryczne - Elektrisch Apparaat - Электрооборудование - Elektrisk apparat - Elektrisk utrustning - Elektromos készülék.
 C - Apparechiatura Gas - Gas Appliance - Appareil à Gaz - Sistema de gas - Gasgerät - Aparelhagem a gás - Urządzenie Gazowe - Gasapparaat - Газовое оборудование - Gassdrevet apparat - Gas utrustning - Gázkészülék.

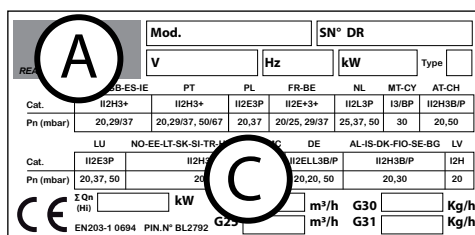
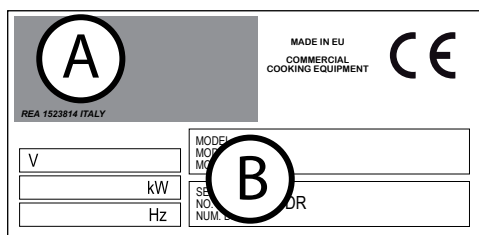

QUADRO NORMATIVO DI RIFERIMENTO - STANDARDS OF REFERENCE TABLEAU NORMATIF DE REFERENCE - MARCO REGLAMENTARIO DE REFERENCIA - REFERENZNORMEN - QUADRO NORMATIVO DE REFERÊNCIA - RAMY REGULACYJNE ODNIESIENIA - TABEL MET NORMREFERENTIES - СПРАВОЧНЫЕ НОРМАТИВНЫЕ СТАНДАРТЫ - RAMMEBETINGELSER - REGELVERK - VONATKOZÓ SZABÁLYOZÁSI KERET

	Regolamento 2016/426/CE Regulation 2016/426 / EC Règlement 2016/426 / CE Reglamento 2016/426 / CE Verordnung 2016/426 / EG Regulamento 2016/426 / CE Verordening 2016/426 / EG Правило 2016/426 / EC Rozporządzenie 2016/426 / WE Förordning 2016/426 / EG Forordning 2016/426 / EF 2016/426 / EK rendelet	Direttiva Bassa Tensione 2014/35/EU Low Voltage Directive 2014/35/EU Directive Basse Tension 2014/35/EU Directiva de baja tensión 2014/35/EU Niederspannungsrichtlinie 2014/35/EU Diretiva baixa tensão 2014/35/EU Dyrektywa Niskonapięciowa 2014/35/EU Richtlijn lage Spanning 2014/35/EU Директива 2014/35/EU ло низковольтному оборудованию Lavspenningsdirektivet 2014/35/EU Lågspänningsdirektivet 2014/35/EU	Direttiva EMC 2014/30/EU EMC Directive 2014/30/EU Directive EMC 2014/30/EU Directiva EMC 2014/30/EU EMV-Richtlinie 2014/30/EU Diretiva EMC 2014/30/EU Dyrektywa EMC 2014/30/EU EMC Richtlijn 2014/30/EU Директива 2014/30/EU ло електромагнитной совместимости EMC Direktivet 2014/30/EU EMC direktivet 2014/30/EU	Smaltimento Apparecchiature elettriche ed elettroniche Waste electrical and electronic equipment Démantèlement des Appareils électriques et électroniques Desguace de equipos eléctricos y electrónicos Entsorgung elektrischer und elektronischer Altgeräte Eliminação das aparelhagens elétricas e eletrónicas Utylizacja odpadów elektrycznych i elektronicznych Afgedankte Elektrische en Elektronische Apparaten Утилизация электрического и электронного оборудования Avhending av elektriske og elektroniske apparater Avtøring av elektriske och elektroniska produkter Elektromos és elektronikus készülékek ártalmatlanítása
GAS-GÁS-GAZ GAZOWY-GAZ - GÁZ ELETTRICO ELECTRIC ELECTRIQUE ELÉCTRICO ELEKTRISCH ELÉTRICO ELEKTRYCZNY ЭЛЕКТРИЧЕСКАЯ ELEKTRISK VILLAMOS		EN 62233:2008; EN 60335-2-36:2002 + A1:2004 + A2:2008 + A11:2012	EN 55014-1:2006 + A1:2009 + A2:2011 EN55014-2:1997 + A1:2001 + A2:2008 EN61000-3-2:2006 + A1:2009 + A2:2009 EN61000-3-3:2008	DIRETTIVA 2011/65/EU (ROHS II) DIRETTIVA 2012/19/EU (WEEE) IRÁNYELV 2012/19/EU

STOVE - SOLID TOP
OPERATING INSTRUCTIONS

EN



01/2019 - Ed 11 - Cod. n° 177376

ELEKTRYCZNY
ELECTRIC
ELEKTRISCH
ELECTRIQUE
ELÉCTRICO
ELÉTRICO
ELETTRICO
ЭЛЕКТРИЧЕСКИЕ ИЗДЕЛИЯ
ELEKTRISK
ELEKTROMOS



0. DOCUMENT IDENTIFICATION

0.1 STANDARDS OF REFERENCE

1. INFORMATION FOR USERS

Foreword - Purpose of document - How to read the document
Keeping the document - Addressees - Operator training program
Pre-arrangements depending on customer - Contents of supply - Intended use
Allowed operational and environmental conditions
Test inspection and warranty - Authorisation

2. GENERAL SAFETY INFORMATION

Foreword - Obligations - Prohibitions - Advice - Recommendations
Indications concerning residual risks
What to do if you smell gas in the room

3. INSTRUCTIONS FOR USE

Location of main components
Knobs, keys and indicator light modes and functions
 Description of stop modes
 Stoppage due to faulty operations
 Emergency stop
 Stoppage during a work phase
Commissioning
 Cleaning at commissioning
Daily activation
Daily and prolonged deactivation
Starting production
 Switching on
 Loading-Unloading the product
 Deactivation

4. ROUTINE MAINTENANCE

Obligations - Prohibitions - Advice - Recommendations
 Daily cleaning
 Cleaning for prolonged deactivation
Summarised table: qualification - operation - frequency
Troubleshooting

5. WASTE DISPOSAL

Deactivation and scrapping of appliance
 Waste disposal

1. INFORMATION FOR USERS

Foreword

This document has been drawn up in the mother language of the manufacturer (Italian). The information it contains is for the sole use of the operator authorised to use the appliance in question.

Operators must be trained concerning all aspects regarding functioning and safety. Special safety prescriptions (Obligations-Prohibitions-Dangers) are carried in a specific chapter concerning these issues. This document cannot be handed over to third parties to take vision of it without written consent by the manufacturer. The text cannot be used in other publications without the written consent of the manufacturer. The use of: Figures/Images/ Drawings/Layouts inside the document, is purely indicative and can undergo variations. The manufacturer reserves the right to modify it, without being obliged to communicate his acts.

Purpose of the document

Every type of interaction between the operator and the appliance during its entire life cycle has been carefully assessed both during designing and while drawing up this document. We therefore hope that this documentation can help to maintain the characteristic efficiency of the appliance. By strictly keeping to the indications it contains, the risk of injuries while working and/or of economical damage is limited to a minimum.

How to read the document

The document is divided into chapters which gather by topics all the information required to use the appliance in a risk-free way. Each chapter is divided into paragraphs; each paragraph can have titled clarifications with subtitles and descriptions.

Keeping the document

This document is an integral part of the initial supply. It must therefore be kept and used appropriately during the entire operational life of the appliance.

Addressees

This document is structured for the exclusive use of the "Generic" operator (Operator with limited responsibilities and tasks). Person authorised and employed to operate the appliance with guards active and capable of performing routine maintenance (cleaning the appliance).

Operator training program

Upon specific demand by the user, a training course can be held for operators in charge of using the appliance, following the modalities provided in the order confirmation.

Depending on the demand, preparation courses can be held at the site of manufacturer or of the user, for:

- Homogeneous operator in charge of electric/electronic maintenance (Specialised technician).
- Homogeneous operator in charge of mechanical maintenance (Specialised technician).
- Generic operator for simple operations (Operator - Final user).

Pre-arrangements depending on customer

Unless different contractual agreements were made, the following normally depend on the customer:

- setting up the rooms (including masonry work, foundations or channelling that could be requested);
- smooth, slip-proof, perfectly level floor;
- pre-arrangement of installation place and installation of equipment respecting the dimensions indicated in the layout (foundation plan);
- pre-arrangement of auxiliary services adequate for requirements of the system (electrical mains, waterworks, gas network, drainage system);
- pre-arrangement of electrical system in compliance with regulatory provisions in force in the place of installation;
- sufficient lighting, in compliance with standards in force in the place of installation;
- safety devices upstream and downstream the energy supply line (residual current devices, equipotential earthing systems, safety valves, etc.) foreseen by legislation in force in the country of installation;
- earthing system in compliance with standards in force;
- pre-arrangement of a water softening system, if needed (see technical details).

Contents of the supply

- Appliance
 - Lid/s
 - Metallic rack/s
 - Rack support grid
 - Pipes and/or wires for connections to energy sources (only when indicated in work order).
- The supply may vary depending on the order.

1. INFORMATION FOR USERS

Intended use

Original instructions. This device is intended for professional use. The use of the appliance treated in this document must be considered "Proper Use" if used for cooking or regeneration of goods intended for alimentary use; any other use is to be considered "Improper use" and therefore dangerous. The appliance must be used according to the foreseen conditions stated in the contract within the prescribed capacity limits carried in the respective paragraphs. **Only use original accessories and spare parts supplied by the manufacturer to maintain regulatory compliance.**

Allowed operating conditions

The appliance has been designed to operate only inside of rooms within the prescribed technical and capacity limits. The following indications must be observed in order to attain ideal operation and safe work conditions. The appliance must be installed in a suitable place, namely, one which allows normal running, routine and extraordinary maintenance operations. The operating area for maintenance must be set up in such a way that the safety of the operator is not endangered.

The room must also be provided with the features required for installation, such as:

- maximum relative humidity: 80%;
- minimum cooling water temperature > + 10 °C ;
- the floor must be anti-slip, and devices positioned perfectly level;
- the room must be equipped with a ventilation system and lighting as prescribed by standards in force in the country of the user;
- the room must be set up for draining greywater, and must have switches and gate valves which cut all types of supply upstream the appliance when needed;
- The walls/surfaces immediately close/contact to the appliance must be fireproof and/or isolated from possible source of heat

Test inspection and warranty

Testing: the equipment has been tested by the manufacturer during the assembly stages at the site of the production plant. All certificates relating to the testing carried out we will be delivered to the customer.

Warranty: The guarantee is of 12 months from invoice date and it covers the faulty parts only. Carriage and installation charges are for the buyer's account. Electric components, accessories as well as other removable parts are not covered by the guarantee.

Labor costs relating to the intervention of authorized by the manufacturer at the customer's premises, for removal of defects under warranty are charged to the dealer, except in cases where the nature of the defect is such that it can be easily removed on site by the customer.

Excluded are all tools and supplies, possibly supplied by the manufacturer together with the machines.

Damage occurred in transit or due to incorrect installation or maintenance can't be considered. Guarantee is not transferable and replacement of parts and appliance is at the final discretion of our company. The manufacturer is responsible for the device in its original setting.

The manufacturer declines all responsibility for improper use, for damages caused as a result of operations not covered in this manual or not authorized in advance by the manufacturer.

The warranty terminates in case of:

- Damage caused by transportation and/or handling. Should this occur, the customer must inform the dealer and carrier via fax or RR and must write what has happened on the copies of the transportation documents. The specialised technician installing the appliance will assess whether it can be installed depending on the damage.

The warranty also terminates in the presence of:





- Damage caused by incorrect installation;
- Damage caused by parts worn due to improper use;
- Damage caused by use of unadvised or non-original spare parts;
- Damage caused by incorrect maintenance and/or lack of maintenance;
- Damage caused by failure to comply with the procedures described in this document.

Authorisation















Authorisation refers to the permission to operate an activity intrinsic to the appliance.

Authorisation is given to anyone who is responsible for the appliance (manufacturer, purchaser, signer, dealer and/or location owner).

Foreword





	The operating instructions have been drawn up for the "Generic" operator (Operator with limited responsibilities and tasks). Person authorised and employed to operate the appliance with guards active and capable of performing routine maintenance (cleaning the appliance).
	The operators who use the appliance must be trained in all aspects concerning its functioning and safety features. They must therefore interact using appropriate methods and instruments, complying with required safety standards.
	This document does not include information regarding transportation, installation and extraordinary maintenance which must be performed by technicians qualified for the relevant operation.
	The "Generic" operator to whom this document is intended must operate on the appliance after the technician has completed installation (transportation, fixing electrical, water, gas and drain connections).
	This document does not include information regarding every modification or variation on the appliance. The manufacturer reserves the right to modify it, without being obliged to communicate his acts.

Obligations - Prohibitions - Advice - Recommendations

	Upon reception, open the packaging and make sure that the appliance and accessories have been damaged during transportation. If damage is found, report it promptly to the carrier and do not install the appliance. Contact qualified and authorised personnel to report the problem detected. The manufacturer is not liable for damage caused during transportation.
	Unauthorised persons (including children, disabled individuals and people with limited physical, sensory and mental abilities) are prohibited from performing any procedures. Generic operators are prohibited from performing any procedures reserved for qualified and authorised technicians. Children shall not play with the appliance. Cleaning and user maintenance shall not be made by children without supervision.
	Read the instructions before acting.
	Disconnect all supplies (electrical - gas - water) upstream the appliance whenever you need to work in safe conditions.
	Wear protective equipment suitable for the operations to be performed. As far as personal protective equipment is concerned, the European Community has issued Directives which the operators must comply with. Noise ≤ 70 dB
	Do not leave flammable objects or material near the appliance. Do not obstruct the heat extraction and/or dissipation openings.
	Refer to standards in force for disposal of special waste.
	When loading the product into the appliance and unloading it, there is a residual risk of being burnt; this risk can occur coming into unintentional contact with: surfaces, trays, processed material.
	Use the cooking vessels in such a way that while the product is cooking, they are in the operator's sight. Liquid containers can spill during cooking, thus creating dangerous situations.
	Failure to keep the appliance in hygienic conditions could cause it to deteriorate quickly, influencing operation and creating dangerous situations.
	It is strictly forbidden to tamper with or remove the plates and pictograms applied to the equipment.
	Store this document carefully, so that it is available for whoever uses the appliance, consulting it when needed.
	The controls on the appliance can only be switched by hand. Damage caused by sharp objects or the likes terminate all and any warranty rights.
	In order to minimise the risk of shocks or fire, do not connect or disconnect the unit with wet hands.
	Whenever you access the cooking area, always remember that the danger of being burnt persists. It is therefore mandatory to take appropriate measures for personal protection.

Indications concerning residual risks

Though the rules for "good manufacturing practice" and the provisions of law which regulate manufacturing and marketing of the product have been implemented, "residual risks" still remain which, due to the very nature of the appliance, were not possible to eliminate. These risks include:

	Residual risk of electrocution: This risks remains when intervening on live electrical and/or electronic devices.
	Residual risk of burning: This risks remains when unintentionally coming into contact with materials at high temperatures.
	Residual risk of burning due to leaking material This risks remains when coming into contact unintentionally with leaking materials at high temperatures. Containers too full of liquids and/or solids which when heated change morphology (passing from a solid state to a liquid state) can cause burning if used improperly. During work, the containers which are used must be positioned at easily visible levels.
	Residual risk of explosions This risk remains when: <ul style="list-style-type: none"> • there is smell of gas in the room; • appliance used in an atmosphere containing substances which risk exploding; • using food in closed containers (such as jars and cans), if they are not suitable for the purpose.
	Residual risk of fire This risk remains when: <ul style="list-style-type: none"> • using with flammable liquids (such as alcohol).

What to do if you smell gas in the room

 **If you detect the smell of gas in the room, it is mandatory to implement the following procedures urgently**

1. Immediately cut the gas supply (shut the gas valve, detail A).
2. Ventilate the room immediately.
3. Do not activate any electrical device in the room (Detail B-C-D).
4. Do not activate any device that can produce sparks or flames (Detail B-C-D).
5. Use a communication device outside of the room where the smell of gas has occurred to inform the responsible bodies (electrical company and/or fire department).

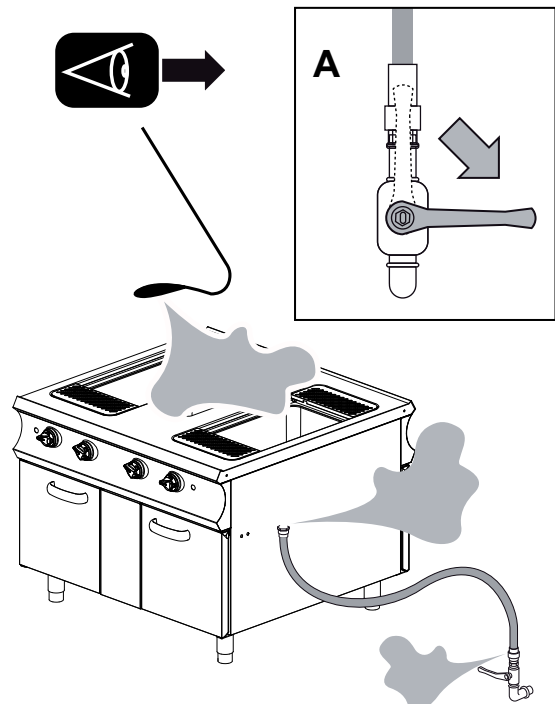

B

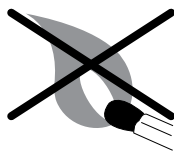

C

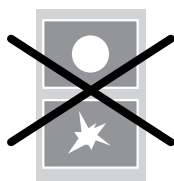

D

Location of main components

The layout of the figures is purely indicative and can undergo variations.

1. Hotplate switch-on and temperature control knob;
2. Oven switch-on and temperature control knob;
3. Green indicator light;
4. Yellow indicator light;
5. Hotplate;
6. Cooking Compartment (Oven).

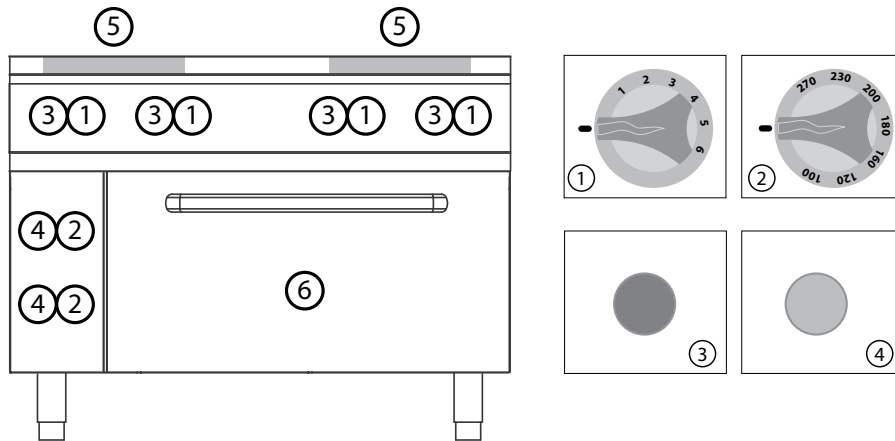

Knobs, keys and indicator light modes and functions

The layout of the figures is purely indicative and can undergo variations.

	Thermostat knob (ELECTRIC). It performs two different functions: <ol style="list-style-type: none"> 1. Adjusting cooking temperature. 2. Heating phase Start/Stop.
	Switch-on knob (ELECTRIC). Performs one function: <ol style="list-style-type: none"> 1. Switches electricity inside circuit on and off.
	Yellow indicator light (GAS/ELECTRIC): When present, the indicator is subordinated to use of the thermostat knob. Lighting of the indicator signals the heating phase.
	Green indicator light (GAS/ELECTRIC): The indicator is subordinated to use of the switch-on knob. Lighting of the indicator signals the operating phase.

3. INSTRUCTIONS FOR USE

Description of stop modes

	In stoppage conditions caused by faults and emergencies, in the event of imminent danger, it is mandatory to close all the locking devices on the supply lines upstream the appliance (Electrical-Water-Gas).
	The drawing illustrates the various positions the knobs take on during an emergency stop (A1-B1-C1-D1-E1) and stoppage during a working phase (A2-B2-C2-D2-E2).

Stoppage due to faulty operations

Safety thermostat

Standard supply with following models:

- Fryer (present on all models)
- Tilting Pan (present on all models)
- Pot (present on all models)
- Pasta cooker (only with Electric model)
- Stove (present on all models with electric oven)
- Frytop present on all electric models (only for 900-980)
- Lava stone (not present)
- Bain-marie (not present)
- All hotplate (only for 900-980: present on all models with gas oven)

Stop: In situations or circumstances which can be dangerous, a safety thermostat is triggered, automatically stopping heat generation. The production cycle is interrupted until the cause of the fault is resolved.

Restarting: After the problem that triggered the safety thermostat is resolved, the authorised technician can restart the appliance by means of the specific controls.

Emergency stop

In situations or circumstances which can be dangerous, turn the knob to “Zero” depending on the model (A-B-C-D-E-1). See knobs, keys and indicator light modes and functions.

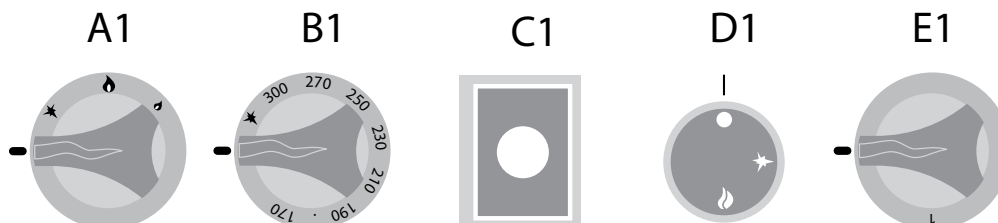

Stoppage during a work phase





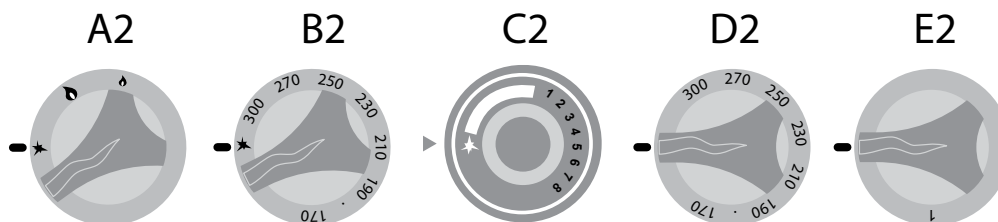

In situations or circumstances which require temporary stop of heat generation, act as follows:

- Gas Appliance: Turn the knobs to the piezoelectric position (A-B-C-2), the pilot light remains lit as the gas flow in the burner is not interrupted.
 - Electric Appliance: Turn the knobs “D2-E2” to “Zero” to stop heat generation.
- (See knobs, keys and indicator light modes and functions).



3. INSTRUCTIONS FOR USE



Commissioning

	When commissioning the appliance and when starting it after a prolonged stop, it must be thoroughly cleaned to eliminate all residue of extraneous material (See Routine Maintenance).
    	Cleaning at commissioning Do not use pressurised or direct water jets to clean the appliance. Remove the outer protective film by hand and thoroughly clean all the outside parts of the appliance. At the end of the operations described for cleaning the outside parts, proceeded as instructed in "Daily Cleaning" (See Routine Maintenance).

Daily activation

Procedure:

1. Check the cleanliness and hygiene of the appliance.
2. Make sure that the room exhaust system works properly.
3. When necessary, plug the appliance into the appropriate socket.
4. Open the network locks upstream the appliance (Gas - Water - Electric).
5. Make sure that the water drain (if present) is not clogged.
6. Proceed with the operations described in "Starting production".

	Air bubbles may form inside the gas supply network (if never used or used every now and then). The plant must be set so as to eliminate this problem.
	In order to free air in the pipes, open the network lock, turn the knob of the appliance while pressing it in the piezoelectric position, place a flame (match or the likes) on the pilot light and wait for it to ignite.
	When the pilot light has been lit, turn the knob to "maximum" for a few seconds in order to stabilise the flame. Afterwards reposition the knob at "Zero" and, if needed, close the network gate valve.

Daily and prolonged deactivation





Procedure:

1. Close the network locks upstream the appliance (Gas - Water - Electric).
2. Make sure that the drain cocks (if present) are "Closed".
3. Check the cleanliness and hygiene of the appliance (See Routine Maintenance).

	In the event of prolonged inactivity, protect the parts more exposed to oxidation as described in the specific chapter (See Routine Maintenance).
---	---

3. INSTRUCTIONS FOR USE



Starting production

	Before proceeding with these operations, see "Daily activation".
	When loading the product into the appliance and unloading it, there is a residual risk of being burnt; this risk can occur coming into unintentional contact with: hob - cooking compartment - recipients or material processed.
	Take appropriate measures for personal protection. Wear protective equipment suitable for the operations to be performed.
	The products must be placed in the specific cooking containers and positioned correctly on the hotplates and/or in the cooking compartment of the oven.
	Use pots with diameter smaller than cooking plate.

Switching On/Off

Do as follows to begin the cooking process:

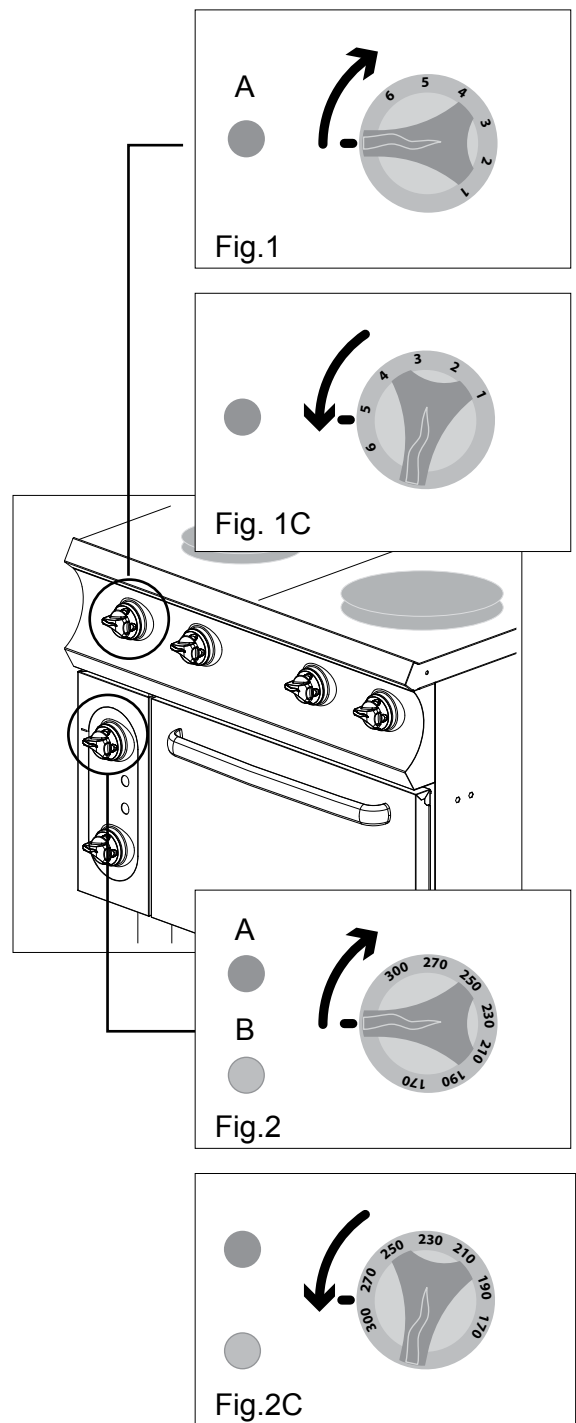

1. Turn the knob to adjust the cooking temperature (Fig. 1 HOTPLATES -Fig. 2 OVEN).
2. When the green light is on it means operation is in progress (Fig. 1-2 A)
When the yellow light is on it means heating is in progress (Fig. 2 B).
3. Turn the knob to "Zero" (Fig. 1-2 C) to stop heat generation.

	The oven cooking temperature is set by turning the thermostat knob. (See indications on knob).
	Hotplate heating speed is set by turning the knob (Position 0-6). Position 6 is the maximum heating speed.



3. INSTRUCTIONS FOR USE

Loading-Unloading the product

	The amount of the product inside the container must not exceed 3/4 its capacity.
	The products to be cooked must be placed in the specific containers away from the appliance area and positioned correctly in the cooking compartment (oven) and/or on the hotplates.

Place the container in the middle of the hotplate (Fig. 3).

When cooking is over, remove the container from the hotplate and put it in a place prepared beforehand.

Open the oven door to load it.

Put the container in the cooking compartment in the middle of the grid (Fig. 4). Close the oven door.



	When opening the doors, step to the side of the appliance to avoid direct heat.
---	---

When the product is cooked, unload it and put it in a place prepared beforehand.

After the product has been unloaded, load it once again or else perform the operations described in "Deactivation".

Deactivation

At the end of the work cycle, turn the knobs on the appliance to "Zero".

	The appliance must be cleaned regularly and every incrustation or food deposit removed. See chapter: "Maintenance".
	If present, the indicator lights must be off at the end of the work cycle.

Check the cleanliness and hygiene of the appliance; see "Maintenance".

Close the network locks upstream the appliance (Gas - Water - Electric).

Make sure that the drain cocks (if present) are "Closed".

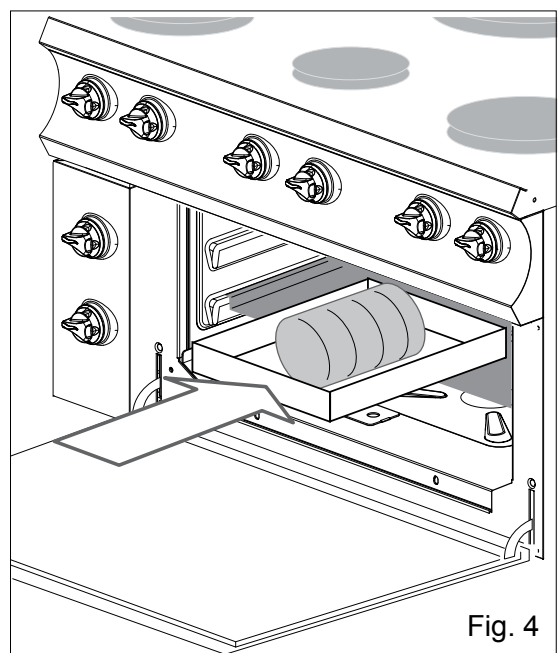
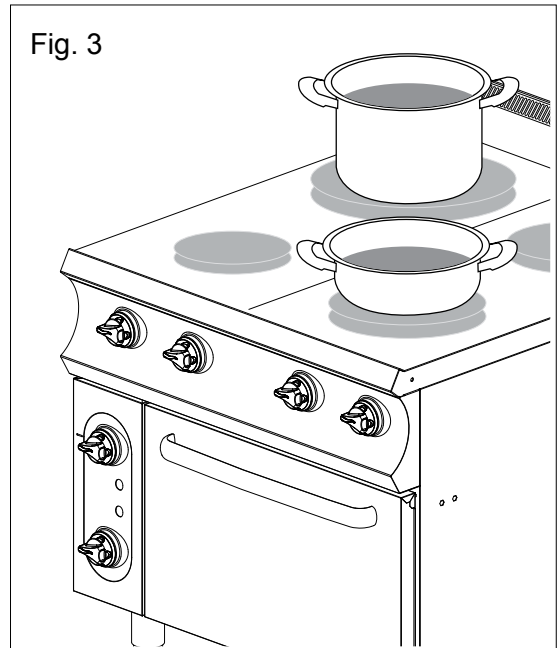



























Fig. 4

4. ROUTINE MAINTENANCE



Obligations - Prohibitions - Advice - Recommendations









	If the appliance is connected to a flue, the exhaust pipe must be cleaned according to that foreseen by specific regulatory provisions of the country (contact your installer for information).
	To make sure that the appliance is in perfect technical conditions; have it serviced at least once a year by an authorised technician of the assistance service.
	Unauthorised persons (including children, disabled individuals and people with limited physical, sensory and mental abilities) are prohibited from performing any procedures. Performing any procedures without first having read all the documentation is strictly prohibited.
 	Whenever you access the cooking area, always remember that the danger of being burnt persists. It is therefore mandatory to take appropriate measures for personal protection.
 	Disconnect electrical power upstream the appliance whenever you need to work in safe conditions to perform cleaning or maintenance.
	Wear protective equipment suitable for the operations to be performed. As far as personal protective equipment is concerned, the European Community has issued Directives which the operators must comply with.
	The appliance is used to prepare food products. Keep the appliance and the surrounding area constantly clean. Failure to keep the appliance in ideal hygienic conditions could cause it to deteriorate quickly and create dangerous situations.
	Filth deposit built up near heat sources can burn during normal use of the appliance and create dangerous situations. The appliance must be cleaned regularly and every incrustation or food deposit removed.
	The chemical effect of salt and/or vinegar or other acid substances can in the long run cause the inside of the cooking compartment to corrode during cooking. At the end of the cooking cycle of such substances, the appliance must be washed thoroughly with detergent, abundantly rinsed and carefully dried.
	Be careful not to damage stainless steel surfaces. Do not use corrosive products, abrasive material or sharp tools.
	The liquid detergent for cleaning the cooking compartment must have certain chemical features: pH greater than 12, without chlorides/ammonia, viscosity and density similar to water. Use non-aggressive products for cleaning the inside and outside of the appliance (use detergents on the market for cleaning steel, glass and enamel).
	Carefully read the indications carried on the labels of the products used. Wear protective equipment suitable for the operations to be performed (see the protective equipment carried on the package label).
	Do not use pressurised or direct water jets to clean the appliance. Rinse the surfaces with tap water and dry them with an absorbent cloth or other non-abrasive material.
	In the event of prolonged inactivity, besides disconnecting the supply lines, you must thoroughly clean all the inside and outside parts of the appliance.
	Before performing any of the cleaning operations described hereafter, the operator must have had a look at the whole document.
   	Refer to standards in force for waste disposal.
	Wait for the temperature of the appliance and all its parts to cool off, so that the operator is not burnt





	<p>Daily hotplate cleaning</p> <p>Use a standard sprayer to apply the liquid detergent on the whole surface of the cooking compartment and, using a non-abrasive sponge, clean the entire surface thoroughly by hand.</p> <p>When finished, rinse the cooking compartment abundantly with tap water (do not use pressurised and/or direct water jets).</p> <p>When these operations have been performed successfully, dry the cooking compartment carefully using a non-abrasive cloth. If necessary, repeat the operations described above for a new cleaning cycle.</p> <p>Humidity residue deposited on the hotplate/s can damage the appliance and cause the hotplate/s to wear quickly.</p> <p>In order to eliminate all humidity, once routine cleaning has been finished, turn the appliance on and run it at minimum for approximately 2/3' and then turn it back off (see procedure part 3 Instructions for use: Switching On/Off).</p>
	<p>Daily oven cleaning</p> <p>Depending on the appliance, remove: grills, trays or other objects removed from the cooking compartment.</p> <p>Heat up the cooking compartment for about 20'.</p> <p>Open the door to let the cooking compartment cool off for a few seconds.</p> <p>Use a standard sprayer to apply the liquid detergent on the whole surface of the cooking compartment and, using a non-abrasive sponge, clean the entire surface thoroughly by hand.</p> <p>When finished, rinse the cooking compartment abundantly with tap water (do not use pressurised and/or direct water jets).</p> <p>When these operations have been performed successfully, dry the cooking compartment carefully using a non-abrasive cloth.</p> <p>If necessary, repeat the operations described above for a new cleaning cycle.</p> <p>Clean the parts previously removed from the cooking compartment (grills, trays and other removable objects) with detergent and tap water, rinse them carefully and dry them before putting them back.</p> <p>In order to eliminate all humidity, once routine cleaning has been finished, turn the appliance on and run it at minimum for approximately 20' and then turn it back off (see procedure part 3 Instructions for use: Switching On/Off).</p>
	<p>Cleaning for prolonged deactivation</p> <p>When the appliance remains idle for a long time, perform all the described daily cleaning procedures.</p> <p>When the operations are over, protect the parts more exposed to oxidation doing as follows.</p> <ul style="list-style-type: none"> • Use lukewarm water with a bit of soap to clean the parts; • Rinse the parts thoroughly, without using pressurised and/or direct water jets; • Dry the surfaces carefully using non-abrasive material; • Wipe a non-abrasive cloth lightly soaked with food-safe Vaseline oil over all of the stainless steel surfaces in order to create a protective film. <p>For appliances with doors and rubber gaskets, leave the door slightly ajar to let it air out and spread protective talcum powder on the rubber gasket surfaces.</p> <p>Air out the appliances and rooms regularly.</p>

4. ROUTINE MAINTENANCE

Summarised table: qualification - operation - frequency

	Generic operator Person authorised and employed to operate the appliance with guards active, capable of performing routine tasks.
	Homogeneous operator Expert operator authorised for handling, transporting, installing, servicing, repairing and scrapping the equipment.

	OPERATION	FREQUENCY
	Cleaning at commissioning	Upon arrival after installation
	Cleaning appliance	Daily
	Cleaning parts in contact with foodstuff	Daily
	Cleaning flue	Yearly
	Checking thermostat	Upon arrival after installation - Yearly
	Checking micro switch	Upon arrival after installation - Yearly
	Checking supply cable	Upon arrival after installation - Yearly
	Checking safety valve	Upon arrival after installation - Every 6 months
	Cleaning hotplates (chromed, cast-iron)	Daily

	Should a problem occur, the generic operator performs the first search and, if qualified, eliminates the cause of the problem and restores the appliance correctly
	If the problem cannot be resolved, turn the appliance off, disconnect it from the electrical mains and shut all the supply valves. Then contact authorized customer service
	The maintenance technician intervenes when the generic operator was not able to pinpoint the cause of the problem, or whenever restoration of correct operation of the appliance entails executing operations for which the generic operator is not qualified
	If the supply cable should be damaged, contact authorized customer service for replacement

4. ROUTINE MAINTENANCE

Troubleshooting



Whenever the appliance does not work properly, try to solve the less serious problems using this table.

FAULT	POSSIBLE CAUSE	INTERVENTION
The appliance does not turn on.	<ul style="list-style-type: none">• The master switch is not connected.• The residual current device or circuit breaker has tripped.	<ul style="list-style-type: none">• Connect the master switch.• Restore the residual current device or circuit breaker.
The inner walls of the tank are covered with limestone.	<ul style="list-style-type: none">• The water is too hard; the softener is finished.	<ul style="list-style-type: none">• Connect the appliance to a water softener.• Regenerate the water softener.• Descale the cooking compartment.
The cooking compartment is stained.	<ul style="list-style-type: none">• Quality of the water.• Ineffective detergent.• Insufficient rinsing.	<ul style="list-style-type: none">• Filter the water (see water softener).• Use the recommended detergent.• Rinse once again.
The light indicators do not turn on.	<ul style="list-style-type: none">• The master switch is not connected.• The residual current device or circuit breaker has tripped.	<ul style="list-style-type: none">• Connect the master switch.• Restore the residual current device or circuit breaker.



If the problem cannot be resolved, turn the appliance off, disconnect it from the electrical mains and shut all the supply valves. Then contact authorized customer service



5. WASTE DISPOSAL

Deactivation and scrapping of appliance



OBLIGATION OF DISPOSING OF MATERIALS USING THE LEGISLATIVE PROCEDURE IN FORCE IN THE COUNTRY WHERE THE APPLIANCE IS SCRAPPED.

In compliance with Directives (see n. 0.1 Section), relating to the reduction of use of hazardous substances in electrical and electronic equipment, as well as waste disposal. The symbol of the barred waste bin carried on the appliance or its packaging indicates that the product at the end of its useful life it must be disposed of separately from other waste.

Differentiated waste collection of this appliance at the end of its life is organised and implemented by the manufacturer. The user who wishes to get rid of this appliance must contact the manufacturer and follow the instructions received to separately dispose of the appliance at the end of its life. An appropriate collection and dispatching of exhausted appliances to environmentally compatible recycling, treatment and disposal plants helps to prevent damaging effects on health and environment and also guarantees that the component parts of exhausted appliances are effectively recycled or reused. Holders of exhausted appliances who dispose of them illegally will be prosecuted.



Specialised personnel is in charge of deactivation and scrapping of the appliance.

Waste disposal



During operation and maintenance, do not disperse pollutants (oils, grease, etc.) into the environment and perform differentiated waste disposal depending on the composition of the different materials and in compliance with relevant laws in force.

Illegal waste disposal will be prosecuted by laws in force in the territory where the violation has been ascertained.