

11/2019

# **Mod: LB50-TT/SS**

**Production code: SM500**

# MANUAL SHEETER

## LB50-TT/SS

### USER'S MANUAL

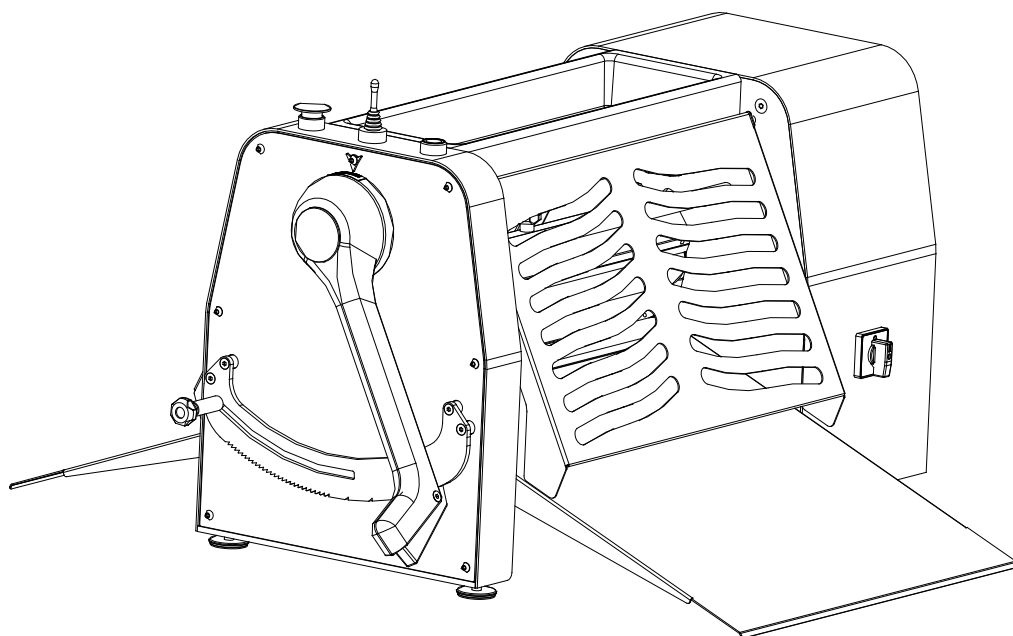

# SUMMARY

<b>1</b>	<b>GENERAL INFORMATIONS.....</b>	<b>5</b>
1.1	PREFACE.....	5
1.2	MACHINE IDENTIFICATION DETAILS.....	5
1.3	WARRANTY .....	6
1.4	MACHINE SPECIFICATIONS .....	6
1.4.1	TECHNICAL SPECIFICATIONS.....	7
1.5	RELEVANT REGULATIONS .....	7
1.6	OPERATING AREA .....	8
1.7	SAFETY AND HEALTH WARNINGS.....	8
1.8	SERVICE AND SPARE PARTS .....	9
1.9	DEMOLITION OF THE MACHINE .....	10
<b>2</b>	<b>INSTALLATION OF MACHINE .....</b>	<b>11</b>
2.1	ENVIRONMENTAL CONDITIONS OF INSTALLATION SITE .....	11
2.2	TRANSPORT AND HANDLING.....	11
2.3	ELECTRICAL CONNECTION .....	11
<b>3</b>	<b>CONTROL AND SAFETY DEVICES .....</b>	<b>13</b>
3.1	CONTROL DEVICES.....	13
3.2	SAFETY DEVICES.....	13
<b>4</b>	<b>USE OF THE MACHINE.....</b>	<b>14</b>
<b>5</b>	<b>MAINTENANCE.....</b>	<b>15</b>
5.1	CLEANING .....	15
<b>6</b>	<b>EXPLOITED VIEW .....</b>	<b>16</b>
<b>7</b>	<b>SPARE PARTS LIST.....</b>	<b>17</b>

# 1 GENERAL INFORMATIONS

## 1.1 PREFACE

This manual is directed towards those who install, operate and maintain the machine so that they can take advantage of the characteristics of the product in the best way. It is important that this manual is kept and remains with the machine if it is moved or if ownership changes so that it can be consulted under all circumstances and therefore the necessary information is available to operate it within safe conditions.

The manufacturer does not take upon themselves the obligation to give notice of possible successive modifications of the product. Furthermore, under the terms of law, this document remains the property of the manufacturer, and tampering, reproduction or transmission to a third party are prohibited without their consent.

The following symbols are used to better stress some passages

**ATTENTION:** indicates hazards that might cause serious damages; attention is required

**NOTE:** indicates particularly important technical information

## 1.2 MACHINE IDENTIFICATION DETAILS

The identification data of the machine are impressed on the plate placed on the rear of the machine (PICT.1.1)

MODEL	_____	CE
SERIAL NUMBER	_____	
DATE OF MANUF.	_____	
VOLTAGE	_____	
FREQUENCY	_____	
PHASE	_____	
AMPS	_____	

PICT.1.1

### **1.3 WARRANTY**

The duration of the guarantee is for two years and runs from the date on the invoice or tax receipt was issued at the time of purchase. Within this period, components that have been unequivocally ascertained to be faulty due to manufacturing defects will be substituted or repaired freely by the manufacturer from their premises, except for electrical components and those subject to wear and tear. The guarantee excludes postage and labour costs.

The guarantee is forfeited in the case of the damage being caused by: transportation, wrong or insufficient maintenance, unskilled operators, tampering, repairs carried out by unauthorised personnel, or failure to comply with the instructions of the manual. Compensation from the manufacturer will not be given for direct or indirect damages arising during any time the machine is inoperative due to its breakdown, it being awaiting repairs, or in any way referable to the non-physical presence of the machine.

### **1.4 MACHINE SPECIFICATIONS**

The manual sheeters are designed and built for exclusive use in foodstuffs for the reduction of puff pastry to the thickness desired to use in the pastry industry.

Manual sheeters consist of:

- Basic structure stove-enamelled with epoxy powders
- A dashboard for operation, a lever for the selection of the rolling direction and machine shutdown
- A pair of dough rolling rollers
- Scrapers to clean the rollers
- A handle to select the rolling thickness
- A flour tray
- Closing case for the transmission bodies

**Pict. 1.2 – Dimensions**

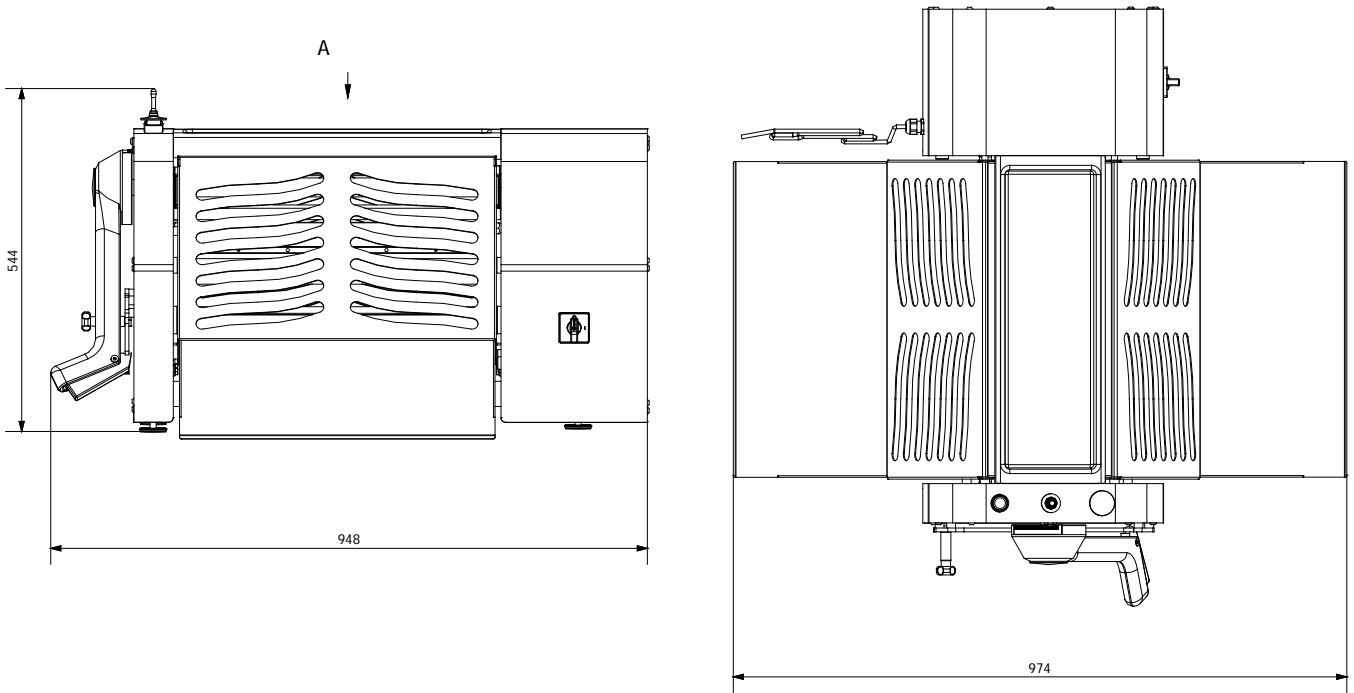

**1.4.1 TECHNICAL SPECIFICATIONS**

Model	Roller speed	Volt/Frequency/Phases	Bowl motor kW	Amp.	Weight kg
SM500	1	400/50-60/3	0.5	1.7	90

**1.5 RELEVANT REGULATIONS**

The machine has been designed and manufactured in accordance with the Machinery Directive 2006/42/CE and the following standards:

- Machinery Directive, Directive 2006/42/EC
- Directive 2014/30/EU
- Directive 2014 35 UE
- Regulation (EC) No 1935/2004

## 1.6 OPERATING AREA

In the normal working conditions and to have the best exploration of the potentiality of the machine, the operator needs the area represented in Pict. 1.2

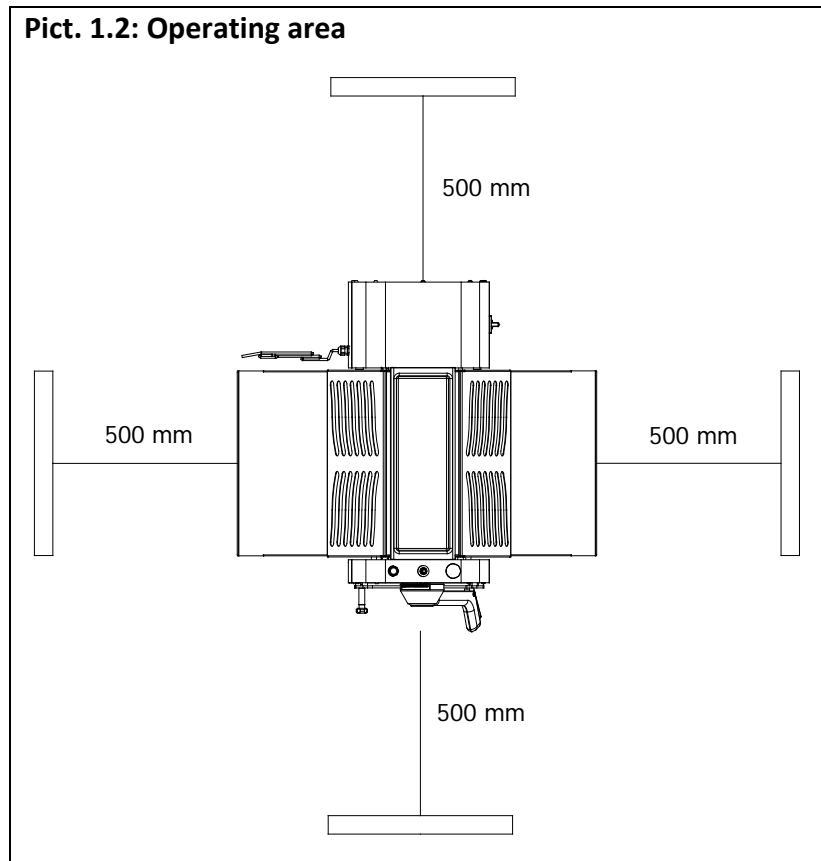

## 1.7 SAFETY AND HEALTH WARNINGS

Although the machine is built in conformity to the required security rules regarding electrical, mechanical and hygienic regulation it can be dangerous if:

- Used in case and condition different to those described by the manufacturer.
- Manomission of the protection and of the safety devices.
- Inattention to the instruction of: Installation - Functioning - Usage - Maintenance.

**In particular:**

- Do not use the machine in humid, wet or nably lit environments, close to inflammable liquids or gas.**
- Keep away from children and non authorized personnel.**

- C) Only utilize the machine with the correct voltage. Normal usage gives better results.
- D) Dress in adequate way. Do not wear hanging clothes or any items which can be caught in the machine. Use non-slip shoes. For hygiene and safety keep your hair tied back and wear protective gloves.
- E) Protect the cable. Do not pull the cable to extract the plug. Do not leave the cable near high temperatures, sharp objects, water or solvents.
- F) Take the plug out. When the machine is not in use, before cleaning, maintenance and moving it.
- G) Check that the machine is not damaged. Before using the machine carefully check that all security devices are working. Check that: the mobile parts are not blocked, there are not any parts damaged, all the parts have been set up correctly and all the conditions that could influence the regular functioning of the machine are in working order.
- H) Repairing the machine by qualified personnel. The repairs can only be done by qualified people, using original spare parts.

The manufacturer declines any responsibility for damages to people, animals or things caused by the non-observance or non-respect of instructions for installation, use and maintenance contained in this manual.

## **1.8 SERVICE AND SPARE PARTS**

For questions on service and spare parts please contact your local dealer and state the following information (see data plate):

- Type of machine
- Year of production
- Reference number of the required piece as indicated in the drawing enclosed).

**Use only genuine spare parts.**

## 1.9 DEMOLITION OF THE MACHINE

In case of dismantling and demolition of the machine, the pieces which the machine is made of, do not present any kind of danger that necessitates any particular caution. To facilitate the recycling process, you must separate the different parts according to material type and provide the scrapping in compliance with the existing laws and regulations.

## 2 INSTALLATION OF MACHINE

The machine should be installed in a well-ventilated room protected from dust and direct contact with atmospheric agents.

The machine must remain packed until the final installation at the place of employment.

### 2.1 ENVIRONMENTAL CONDITIONS OF INSTALLATION SITE

The environmental conditions in which the machine must be installed must follow these characteristics:

- *Temperature:* +5/+40° C, with the average temperature not exceeding 35°C over a period of 24 hours.
- *Relative humidity:* from 30% to 95% in the absence of condensation
- Water and heat sources at safe distance from the machine
- Well-dimensioned flat and stable surface

### 2.2 TRANSPORT AND HANDLING

SM series machines are supplied in cardboard boxes on wooden pallets . After removing the packaging and the plastic protection, with the aid of appropriate capacity belts placed under the base of the machine and a suitable lifting means (manual or powered), lift the machine, remove the underlying pallet, place it in the foreseen location, taking care to leave a free space of approximately 50 cm around the machine in order to facilitate use, cleaning and maintenance operations of the machine.

### 2.3 ELECTRICAL CONNECTION

The machine is equipped with connecting cable located on the back of the machine. It's essential to mount a normalized and polarized plug at the end of the cable.

The electric net must be provided with an automatic differential switch and this has to be suitable to the machine

The electrical plug must be easy to access, no moving should be necessary.

#### ATTENTION

**Before proceeding to the electrical connection, ensure that voltage and frequency are the same declared by the Manufacturer and shown on the identification plate.**

## **ATTENTION**

**Any electrical intervention involving the working site is to be carried out by qualified and skilled technicians.. The manufacturer will not be liable for defects, breakdowns or malfunctioning arising from the non-compliance with the power supply values stated.**

### 3 CONTROL AND SAFETY DEVICES

The machines are fitted with the following operation and safety devices: (PICT. 3.1):

#### 3.1 CONTROL DEVICES

A - MAIN SWITCH

B - START BUTTON

C - STOP BUTTON

E - CONVEYOR REVERSE MANUAL CONTROL LEVER

G - DOUGH THICKNESS ADJUSTMENT LEVER

#### 3.2 SAFETY DEVICES

H - ROLLING ROLLERS PROTECTION

PICT. 3.1

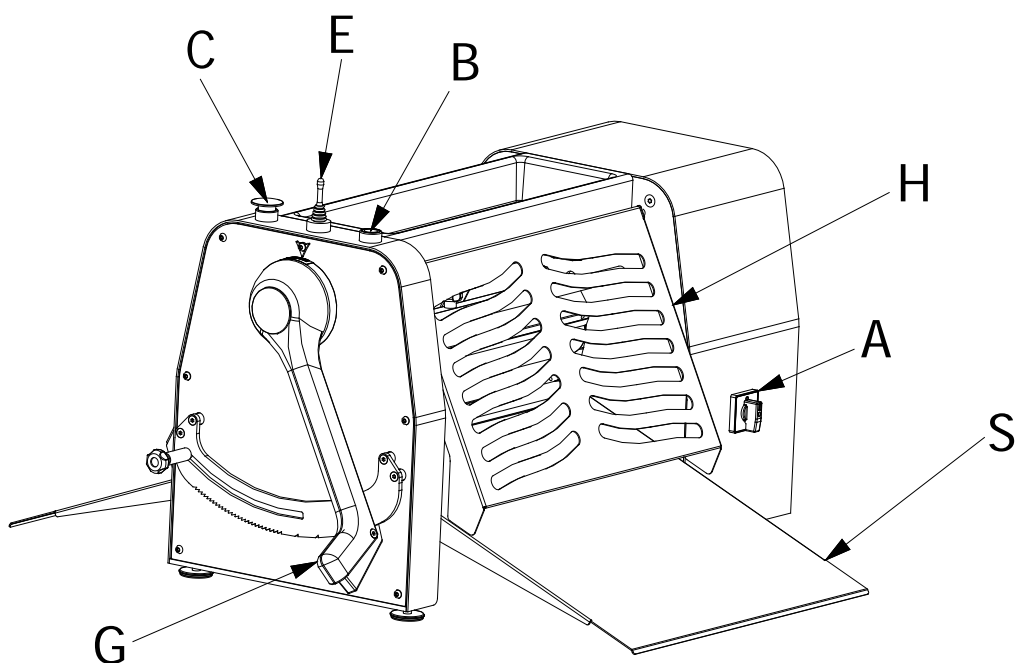

## 4 USE OF THE MACHINE

Before starting each work cycle make sure that the machine is perfectly clean, particularly the conveyors and rolling cylinders that should be treated with detergents compatible with foodstuffs. If necessary, clean in accordance with the methods in 5.1.

1. TURN THE MAIN SWITCH "A" ON POSITION 1
2. PRESS THE HANDLE OF THE DOUGH THICKNESS ADJUSTMENT LEVER "G"
3. PRESS START BUTTON "B"
4. OPERATE LEVER "E" AND START ROLLING
5. IN CASE OF OPENING OF THE PROTECTION GRID "H" THE MACHINE STOPS. TO RESTART, CLOSE THE GRID AND PRESS START BUTTON "B" AGAIN
6. TO STOP THE MACHINE POSITION LEVER "E"
7. FOR EMERGENCY STOP, PRESS THE EMERGENCY STOP BUTTON "C"

## 5 MAINTENANCE

### ATTENTION

Disconnect the plug from the electricity supply before carrying out any maintenance or cleaning interventions. In case of the malfunctioning or breakdown of the machine, contact only the assistance centres authorised by the manufacturer.

### 5.1 CLEANING

Cleaning should be done at the end of each usage in compliance with hygiene requirements and to protect the functionality of the machine.

With the aid of a suction machine, remove all residues of flour and dough . Remove the dough scraper before cleaning the cylinders.

Remove residues of dough and flour using a soft sponge and warm water, dry with absorbent paper for food, then first go over the areas mentioned, and then the whole machine with a soft, clean cloth moistened with specific disinfectant for food machines.

### ATTENTION

It is recommended not to use non-food abrasive or corrosive chemicals in any case. Absolutely avoid using water jets, various tools, rough or abrasive means such as steel scouring pads, sponges, etc. that may damage the surfaces and above all compromise the safety from a sanitary standpoint. To maintain both performance efficiency and the safety of the machine, it is essential to carry out periodic maintenance of the following items (at least once every 6 months).

# SFOGLIATRICE MANUALE

## LB50-TT/SS

### MANUALE D'USO

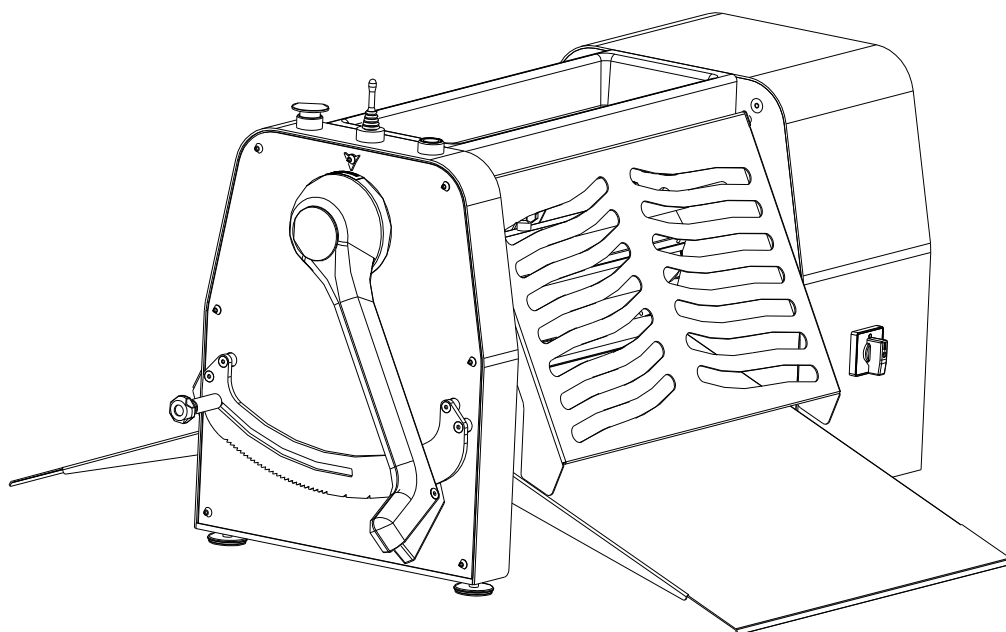

# SOMMARIO

<b>1</b>	<b>GENERAL INFORMATIONS.....</b>	<b>5</b>
1.1	PREFACE.....	5
1.2	MACHINE IDENTIFICATION DETAILS.....	5
1.3	WARRANTY.....	6
1.4	MACHINE SPECIFICATIONS.....	6
1.4.1	TECHNICAL SPECIFICATIONS.....	7
1.5	RELEVANT REGULATIONS.....	7
1.6	OPERATING AREA.....	8
1.7	SAFETY AND HEALTH WARNINGS.....	8
1.8	SERVICE AND SPARE PARTS.....	9
1.9	DEMOLITION OF THE MACHINE.....	10
<b>2</b>	<b>INSTALLATION OF MACHINE.....</b>	<b>11</b>
2.1	ENVIRONMENTAL CONDITIONS OF INSTALLATION SITE.....	11
2.2	TRANSPORT AND HANDLING.....	11
2.3	ELECTRICAL CONNECTION.....	11
<b>3</b>	<b>CONTROL AND SAFETY DEVICES.....</b>	<b>13</b>
3.1	CONTROL DEVICES.....	13
3.2	SAFETY DEVICES.....	13
<b>4</b>	<b>USE OF THE MACHINE.....</b>	<b>14</b>
<b>5</b>	<b>MAINTENANCE.....</b>	<b>15</b>
5.1	CLEANING.....	15
<b>6</b>	<b>EXPLOITED VIEW.....</b>	<b>16</b>
<b>7</b>	<b>SPARE PARTS LIST.....</b>	<b>17</b>

# 1 INFORMAZIONI GENERALI

## 1.1 PREFERAZIONE

This manual is directed towards those who install, operate and maintain the machine so that they can take advantage of the characteristics of the product in the best way. It is important that this manual is kept and remains with the machine if it is moved or if ownership changes so that it can be consulted under all circumstances and therefore the necessary information is available to operate it within safe conditions.

The manufacturer does not take upon themselves the obligation to give notice of possible successive modifications of the product. Furthermore, under the terms of law, this document remains the property of the manufacturer, and tampering, reproduction or transmission to a third party are prohibited without their consent.

The following symbols are used to better stress some passages

**ATTENTION:** indicates hazards that might cause serious damages; attention is required

**NOTE:** indicates particularly important technical information

## 1.2 MACHINE IDENTIFICATION DETAILS

The identification data of the machine are impressed on the plate placed on the rear of the machine (PICT.1.1)

MODEL	_____	CE
SERIAL NUMBER	_____	
DATE OF MANUF.	_____	
VOLTAGE	_____	
FREQUENCY	_____	
PHASE	_____	
AMPS	_____	

PICT.1.1

### **1.3 WARRANTY**

The duration of the guarantee is for two years and runs from the date on the invoice or tax receipt was issued at the time of purchase. Within this period, components that have been unequivocally ascertained to be faulty due to manufacturing defects will be substituted or repaired freely by the manufacturer from their premises, except for electrical components and those subject to wear and tear. The guarantee excludes postage and labour costs.

The guarantee is forfeited in the case of the damage being caused by: transportation, wrong or insufficient maintenance, unskilled operators, tampering, repairs carried out by unauthorised personnel, or failure to comply with the instructions of the manual. Compensation from the manufacturer will not be given for direct or indirect damages arising during any time the machine is inoperative due to its breakdown, it being awaiting repairs, or in any way referable to the non-physical presence of the machine.

### **1.4 MACHINE SPECIFICATIONS**

The manual sheeters are designed and built for exclusive use in foodstuffs for the reduction of puff pastry to the thickness desired to use in the pastry industry.

Manual sheeters consist of:

- Basic structure stove-enamelled with epoxy powders
- A dashboard for operation, a lever for the selection of the rolling direction and machine shutdown
- A pair of dough rolling rollers
- Scrapers to clean the rollers
- A handle to select the rolling thickness
- A flour tray
- Closing case for the transmission bodies

**Pict. 1.2 – Dimensions**

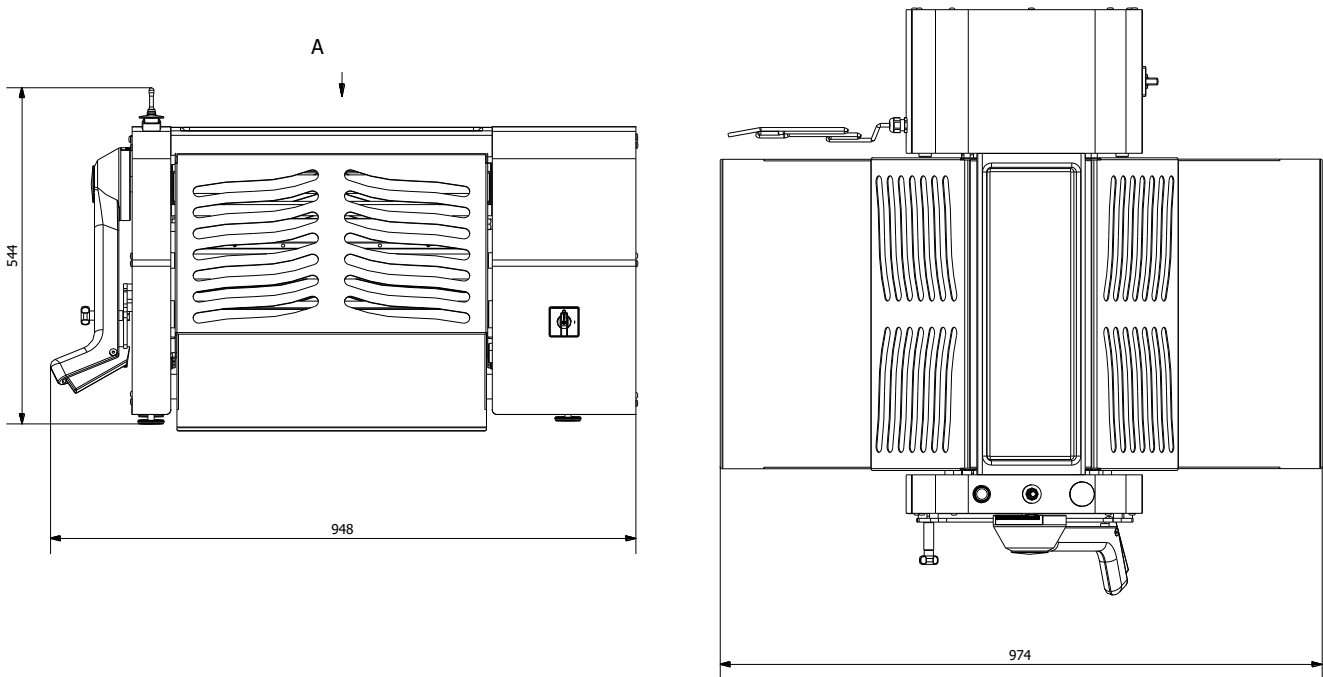

**1.4.1 TECHNICAL SPECIFICATIONS**

Model	Roller speed	Volt/Frequency/Phases	Bowl motor kW	Amp.	Weight kg
SM500	1	400/50-60/3	0.5	1.7	90

**1.5 RELEVANT REGULATIONS**

The machine has been designed and manufactured in accordance with the Machinery Directive 2006/42/CE and the following standards:

- Machinery Directive, Directive 2006/42/EC
- Directive 2014/30/EU
- Directive 2014 35 UE
- Regulation (EC) No 1935/2004

## 1.6 OPERATING AREA

In the normal working conditions and to have the best exploration of the potentiality of the machine, the operator needs the area represented in Pict. 1.2

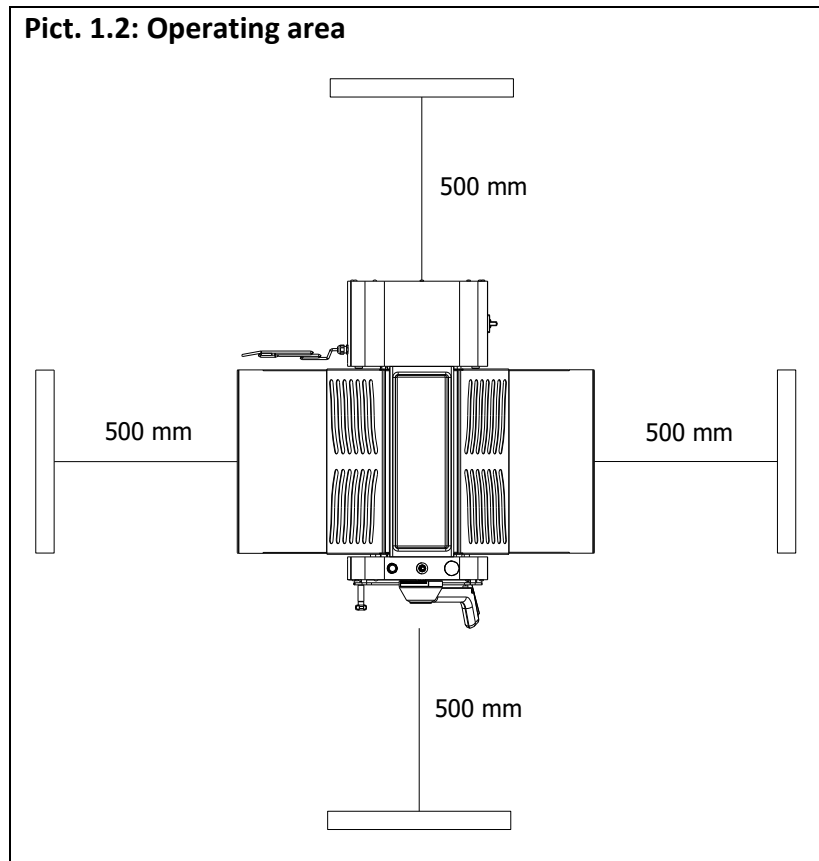

## 1.7 SAFETY AND HEALTH WARNINGS

Although the machine is built in conformity to the required security rules regarding electrical, mechanical and hygienic regulation it can be dangerous if:

- Used in case and condition different to those described by the manufacturer.
- Manomission of the protection and of the safety devices.
- Innattention to the instruction of: Installation - Functioning - Usage - Maintenance.

**In particular:**

- Do not use the machine in humid, wet or nedly lit environments, close to inflammable liquids or gas.**
- Keep away from children and non authorized personnel.**

- C) Only utilize the machine with the correct voltage. Normal usage gives better results.
- D) Dress in adequate way. Do not wear hanging clothes or any items which can be caught in the machine. Use non-slip shoes. For hygiene and safety keep your hair tied back and wear protective gloves.
- E) Protect the cable. Do not pull the cable to extract the plug. Do not leave the cable near high temperatures, sharp objects, water or solvents.
- F) Take the plug out. When the machine is not in use, before cleaning, maintenance and moving it.
- G) Check that the machine is not damaged. Before using the machine carefully check that all security devices are working. Check that: the mobile parts are not blocked, there are not any parts damaged, all the parts have been set up correctly and all the conditions that could influence the regular functioning of the machine are in working order.
- H) Repairing the machine by qualified personnel. The repairs can only be done by qualified people, using original spare parts.

The manufacturer declines any responsibility for damages to people, animals or things caused by the non-observance or non-respect of instructions for installation, use and maintenance contained in this manual.

## **1.8 SERVICE AND SPARE PARTS**

For questions on service and spare parts please contact your local dealer and state the following information (see data plate):

- Type of machine
- Year of production
- Reference number of the required piece as indicated in the drawing enclosed).

**Use only genuine spare parts.**

## 1.9 DEMOLITION OF THE MACHINE

In case of dismantling and demolition of the machine, the pieces which the machine is made of, do not present any kind of danger that necessitates any particular caution. To facilitate the recycling process, you must separate the different parts according to material type and provide the scrapping in compliance with the existing laws and regulations.

## 2 INSTALLATION OF MACHINE

The machine should be installed in a well-ventilated room protected from dust and direct contact with atmospheric agents.

The machine must remain packed until the final installation at the place of employment.

### 2.1 ENVIRONMENTAL CONDITIONS OF INSTALLATION SITE

The environmental conditions in which the machine must be installed must follow these characteristics:

- *Temperature:* +5/+40° C, with the average temperature not exceeding 35°C over a period of 24 hours.
- *Relative humidity:* from 30% to 95% in the absence of condensation
- Water and heat sources at safe distance from the machine
- Well-dimensioned flat and stable surface

### 2.2 TRANSPORT AND HANDLING

SM series machines are supplied in cardboard boxes on wooden pallets . After removing the packaging and the plastic protection, with the aid of appropriate capacity belts placed under the base of the machine and a suitable lifting means (manual or powered), lift the machine, remove the underlying pallet, place it in the foreseen location, taking care to leave a free space of approximately 50 cm around the machine in order to facilitate use, cleaning and maintenance operations of the machine.

### 2.3 ELECTRICAL CONNECTION

The machine is equipped with connecting cable located on the back of the machine. It's essential to mount a normalized and polarized plug at the end of the cable.

The electric net must be provided with an automatic differential switch and this has to be suitable to the machine

The electrical plug must be easy to access, no moving should be necessary.

#### ATTENTION

**Before proceeding to the electrical connection, ensure that voltage and frequency are the same declared by the Manufacturer and shown on the identification plate.**

## **ATTENTION**

**Any electrical intervention involving the working site is to be carried out by qualified and skilled technicians.. The manufacturer will not be liable for defects, breakdowns or malfunctioning arising from the non-compliance with the power supply values stated.**

### 3 CONTROL AND SAFETY DEVICES

The machines are fitted with the following operation and safety devices: (PICT. 3.1):

#### 3.1 CONTROL DEVICES

A - MAIN SWITCH

B - START BUTTON

C - STOP BUTTON

E - CONVEYOR REVERSE MANUAL CONTROL LEVER

G - DOUGH THICKNESS ADJUSTMENT LEVER

#### 3.2 SAFETY DEVICES

H - ROLLING ROLLERS PROTECTION

PICT. 3.1

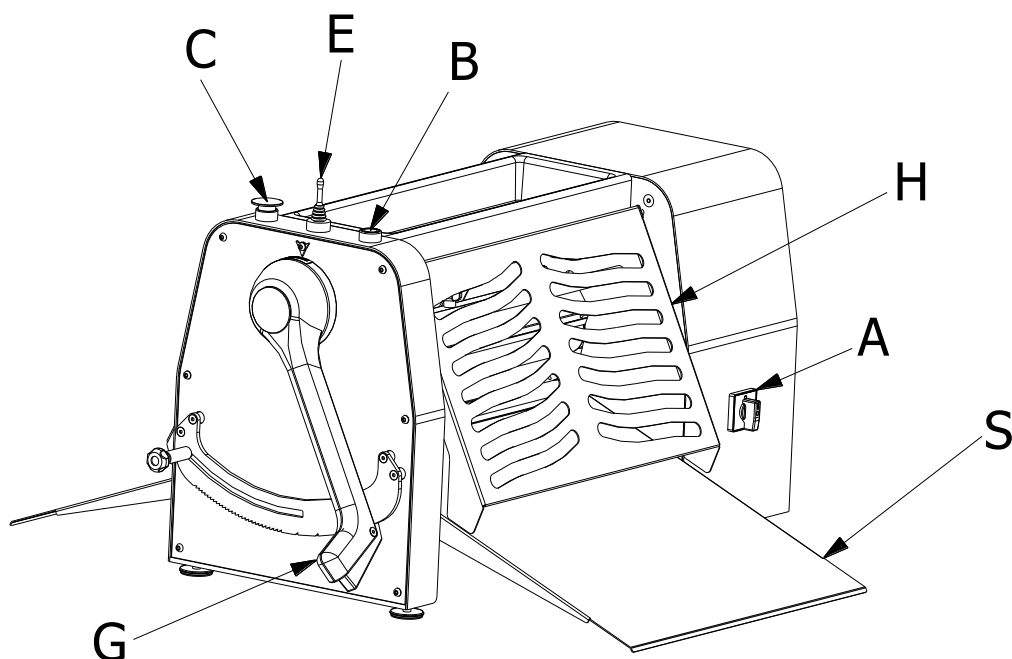

## 4 USE OF THE MACHINE

Before starting each work cycle make sure that the machine is perfectly clean, particularly the conveyors and rolling cylinders that should be treated with detergents compatible with foodstuffs. If necessary, clean in accordance with the methods in 5.1.

1. TURN THE MAIN SWITCH "A" ON POSITION 1
2. PRESS THE HANDLE OF THE DOUGH THICKNESS ADJUSTMENT LEVER "G"
3. PRESS START BUTTON "B"
4. OPERATE LEVER "E" AND START ROLLING
5. IN CASE OF OPENING OF THE PROTECTION GRID "H" THE MACHINE STOPS. TO RESTART, CLOSE THE GRID AND PRESS START BUTTON "B" AGAIN
6. TO STOP THE MACHINE POSITION LEVER "E"
7. FOR EMERGENCY STOP, PRESS THE EMERGENCY STOP BUTTON "C"

## 5 MAINTENANCE

### ATTENTION

Disconnect the plug from the electricity supply before carrying out any maintenance or cleaning interventions. In case of the malfunctioning or breakdown of the machine, contact only the assistance centres authorised by the manufacturer.

### 5.1 CLEANING

Cleaning should be done at the end of each usage in compliance with hygiene requirements and to protect the functionality of the machine.

With the aid of a suction machine, remove all residues of flour and dough . Remove the dough scraper before cleaning the cylinders.

Remove residues of dough and flour using a soft sponge and warm water, dry with absorbent paper for food, then first go over the areas mentioned, and then the whole machine with a soft, clean cloth moistened with specific disinfectant for food machines.

### ATTENTION

It is recommended not to use non-food abrasive or corrosive chemicals in any case. Absolutely avoid using water jets, various tools, rough or abrasive means such as steel scouring pads, sponges, etc. that may damage the surfaces and above all compromise the safety from a sanitary standpoint. To maintain both performance efficiency and the safety of the machine, it is essential to carry out periodic maintenance of the following items (at least once every 6 months).